



# ***MULTI V***<sup>TM</sup>

## **CEILING CASSETTE INDOOR UNIT ENGINEERING MANUAL**



One-Way Ceiling Cassettes  
7,500 to 24,200 Btu/h



Two-Way Ceiling Cassettes  
19,100 to 24,200 Btu/h



Four-Way Ceiling Cassettes  
5,500 to 48,100 Btu/h

## **PROPRIETARY DATA NOTICE**





**This document, as well as all reports, illustrations, data, information, and other materials are the property of LG Electronics U.S.A., Inc., and are disclosed by LG Electronics U.S.A., Inc. only in confidence.  
This document is for design purposes only.**

A summary list of safety precautions is on page 3.

**To access additional technical documentation such as submittals, outdoor unit engineering manuals, installation, service, product data performance, general best practice, and building ventilation manuals, as well as white papers, catalogs, LATS software programs, and more, log in to [www.lghvac.com](http://www.lghvac.com).**

<b>Unit Nomenclature.....</b>	<b>4</b>	<b>Four-Way Ceiling Cassette .....</b>	<b>59</b>
<b>LG Air Conditioner Technical Solution (LATS) .....</b>	<b>5</b>	<i>Mechanical Specifications .....</i>	59
<b>Refrigerant Charge Worksheet.....</b>	<b>7</b>	<i>General Data .....</i>	61
<b>One-Way Ceiling Cassette .....</b>	<b>12</b>	<i>Electrical Data .....</i>	65
<i>Mechanical Specifications .....</i>	12	<i>External Dimensions.....</i>	66
<i>General Data .....</i>	14	<i>Electrical Wiring Diagram .....</i>	70
<i>Electrical Data .....</i>	16	<i>Refrigerant Flow Diagram.....</i>	74
<i>External Dimensions.....</i>	17	<i>Acoustic Data .....</i>	75
<i>Electrical Wiring Diagram .....</i>	19	<i>Air Velocity / Temperature Distribution.....</i>	84
<i>Refrigerant Flow Diagram.....</i>	21	<i>Fresh Air Ventilation.....</i>	106
<i>Acoustic Data .....</i>	22	<i>Cooling Capacity Tables .....</i>	108
<i>Air Velocity / Temperature Distribution.....</i>	26	<i>Heating Capacity Tables.....</i>	118
<i>Fresh Air Ventilation.....</i>	34	<i>Optional Accessories .....</i>	125
<i>Cooling Capacity Tables .....</i>	35	<b>Application Guidelines.....</b>	<b>127</b>
<i>Heating Capacity Tables.....</i>	38	<i>Selecting the Best Location .....</i>	127
<i>Accessories .....</i>	40	<i>General Mounting .....</i>	128
<b>Two-Way Ceiling Cassette .....</b>	<b>42</b>	<i>General Mounting / General Drain Piping Information.....</i>	129
<i>Mechanical Specifications .....</i>	42	<i>Wiring Guidelines .....</i>	131
<i>General Data / Electrical Data .....</i>	44	<i>Wired Controller Placement.....</i>	136
<i>External Dimensions.....</i>	45	<b>Acronyms .....</b>	<b>137</b>
<i>Electrical Wiring Diagram .....</i>	46		
<i>Refrigerant Flow Diagram.....</i>	48		
<i>Acoustic Data .....</i>	49		
<i>Air Velocity / Temperature Distribution.....</i>	51		
<i>Cooling Capacity Tables .....</i>	55		
<i>Heating Capacity Tables.....</i>	56		
<i>Optional Accessories .....</i>	57		

**TABLE OF SYMBOLS**

 <b>DANGER</b>	<i>This symbol indicates an imminently hazardous situation which, if not avoided, will result in death or serious injury.</i>
 <b>WARNING</b>	<i>This symbol indicates a potentially hazardous situation which, if not avoided, could result in death or serious injury.</i>
 <b>CAUTION</b>	<i>This symbol indicates a potentially hazardous situation which, if not avoided, may result in minor or moderate injury.</i>
<b>Note</b>	<i>This symbol indicates situations that may result in equipment or property damage accidents only.</i>
	<i>This symbol indicates an action should not be completed.</i>

# UNIT NOMENCLATURE

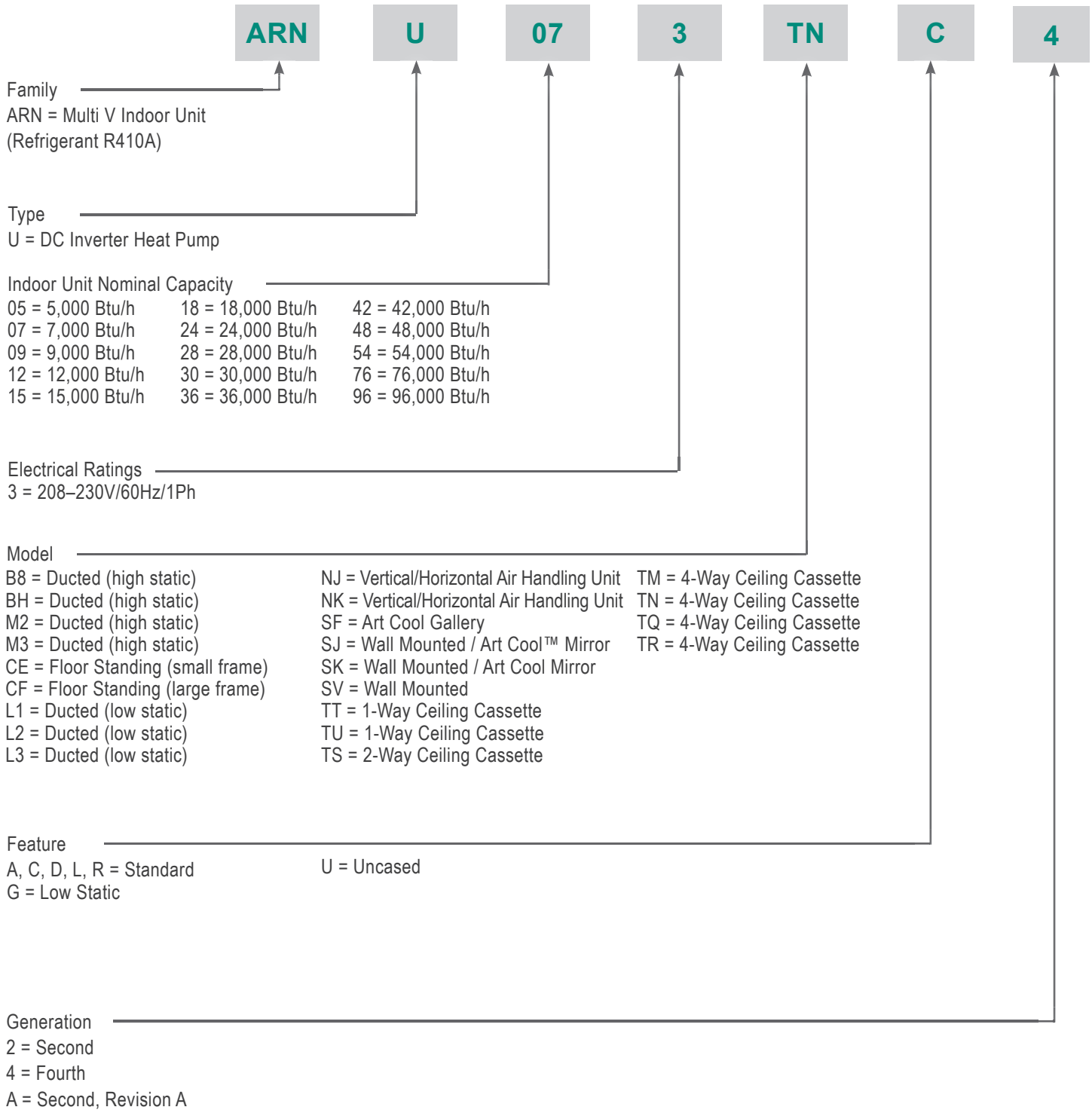

## LG Air Conditioner Technical Solution (LATS) Software

A properly designed and installed refrigerant piping system is critical to the optimal performance of LG air-conditioning systems. To assist engineers, LG offers, free of charge, LG Air Conditioner Technical Solution (LATS) software—a total design solution for LG air conditioning systems.

### Note:

To reduce the risk of designing an improper applied system or one that will not operate correctly, LG requires that LATS software be used on all projects.

### Formats

LATS is available to LG customers in three user interfaces: LATS HVAC, LATS CAD2, and LATS REVIT. All three LATS formats are available through [www.myLGHVAC.com](http://www.myLGHVAC.com), or contact an LG Sales Representative.

**LATS HVAC** is a Windows®-based application that aids engineers in designing LG Variable Refrigerant Flow (VRF), Multi F / Multi F MAX, Single-Zone, and Energy Recovery Ventilator (ERV) systems.

\*Windows® is a registered mark of Microsoft® Corporation.

**LATS CAD2** combines the LG LATS program with AutoCAD® software\*\*. It permits engineers to layout and validate LG Multi V Variable Refrigerant Flow (VRF), Multi F / Multi F MAX, Single-Zone, and Energy Recovery Ventilator (ERV) systems directly into CAD drawings.

**LATS Revit** integrates the LG LATS program with Revit® software\*\*. It permits engineers to layout and validate Multi V VRF systems directly into Revit drawings.

\*\*AutoCAD® and Revit® are both registered marks of Autodesk, Inc.

### Features

All LG product design criteria have been loaded into the program, making LATS simple to use: double click or drag and drop the component choices. Build systems in Tree Mode where the refrigerant system can be viewed. Switch to a Schematic diagram to see the electrical and communications wiring.

LATS software permits the user to input region data, indoor and outdoor design temperatures, modify humidity default values, zoning, specify type and size of outdoor units and indoor units, and input air flow and external static pressure (ESP) for ducted indoor units.

The program can also:

- Import building loads from a separate Excel file.
- Present options for outdoor unit auto selection.
- Automatically calculate component capacity based on design conditions for the chosen region.
- Verify if the height differences between the various system components are within system limits.
- Provide the correct size of each refrigerant piping segment and LG Y-Branches and Headers.
- Adjust overall piping system length when elbows are added.
- Check for component piping limitations and flag if any parameters are broken.
- Factor operation and capacity for defrost operation.
- Calculate refrigerant charge, noting any additional trim charge.
- Suggest accessories for indoor units and outdoor units.
- Run system simulation.

### Note:

Features depend on which LATS program is being used, and the type of system being designed.

Figure 1: Example of LATS CAD2.



# LG AIR CONDITIONER TECHNICAL SOLUTION (LATS)



## LATS Generates a Complete Project Report

LATS software also generates a report containing project design parameters, cooling and heating design data, system component performance, and capacity data. The report includes system combination ratio and refrigerant charge calculations; and provides detailed bill of material, including outdoor units, indoor units, control devices, accessories, refrigerant pipe sizes segregated by building, by system, by pipe size, and by pipe segments. LATS can generate an Excel GERP report that can imported into the LG SOPS pricing and ordering system.

## Proper Design to Install Procedure

LG encourages a two report design-to-install-procedure. After the design engineer determines building / zone loads and other details, the engineer opens the LATS program and inputs the project's information. When the design is complete, the "Auto Piping" and "System Check" functions must be used to verify piping sizes, limitations, and if any design errors are present. If errors are found, engineers must adjust the design, and run Auto Piping and System Check again. When the design passes the checks, then the engineer prints out a project "Shop Drawing" (LATS Tree Diagram) and provides it to the installing contractor. The contractor must follow the LATS Tree Diagram when building the piping system, but oftentimes the design changes on the building site:

- Architect has changed location and/or purpose of room(s).
- Outdoor unit cannot be placed where originally intended.
- Structural elements prevent routing the piping as planned.
- Air conditioning system conflicts with other building systems (plumbing, gas lines, etc.).

Figure 2: Example of a LATS Tree Diagram.

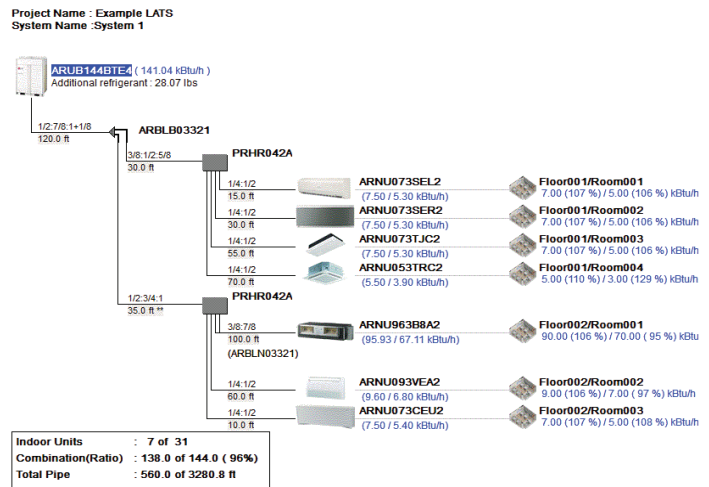

The contractor must mark any deviation from the design on the Shop Drawing, including as-built straight lines and elbows. This "Mark Up" drawing must be returned to the design engineer or Rep, who must input contractor changes into the LATS file. (Copy the original LATS software file, save and rename as a separate file, and modify all piping lengths by double-clicking on each length and editing information.) Like the shop drawing, the Auto Piping and System Check must also be run on this new "As Built" drawing. The design engineer or Rep must then provide the final As Built file to the contractor. The Mark Up version must be compared to the As Built version for:

- Differences in pipe diameter(s). If incorrect diameters have been installed, the piping must be changed out. If pipe diameters have changed, check to see if Y-Branches will also need to be changed.
- Changes to outdoor unit and indoor unit capacities. Capacities changes may impact line length changes.
- Additional refrigerant charge quantity ("Trim Charge"). Trim charge will change if piping lengths and diameters change. The As Built version must reflect installed piping lengths to ensure correct trim charge.

All documents submitted by the contractor, as well as the Shop Drawing and the As Built Drawing files must be provided for commissioning purposes. Model and serial numbers for all system components must also be submitted. If the steps previously detailed are not followed, and all documents are not provided to the commissioning agent, the project runs the risk of not being commissioned and voiding any limited warranty LG offers on the equipment.

# REFRIGERANT CHARGE WORKSHEET

Multi V 5 System R410A Refrigerant Charge Calculator (lbs.)

System Tag or ID:		Job Name: _____				
		Project Manager: _____			Date: _____	
Line #	Description	Chassis I.D.	Size	Quantity	CF (Ref.) <sup>1</sup>	Total (lbs.)
1	Linear feet of 1/4" liquid line tubing <sup>2</sup>	—	—		0.015	
2	Linear feet of 3/8" liquid line tubing <sup>2</sup>	—	—		0.041	
3	Linear feet of 1/2" liquid line tubing <sup>2</sup>	—	—		0.079	
4	Linear feet of 5/8" liquid line tubing <sup>2</sup>	—	—		0.116	
5	Linear feet of 3/4" liquid line tubing <sup>2</sup>	—	—		0.179	
6	Linear feet of 7/8" liquid line tubing <sup>2</sup>	—	—		0.238	
7	Linear feet of 1" liquid line tubing <sup>2</sup>	—	—		0.323	
8	Standard + Art Cool Mirror	SJ, SK	5k to 15k		0.53	
9	Standard + Art Cool Mirror	SJ, SK	18k to 24k		0.62	
10	Standard	SV	30k to 36k		1.01	
11	Art Cool Gallery	SF	9k to 12k		0.22	
12	1-Way Cassette	TU	7k to 12k		0.44	
13	1-Way Cassette	TT	18k to 24k		0.64	
14	2-Way Cassette	TS	18k to 24k		0.75	
15	4-Way 2' x 2' Cassette	TR	5k to 7k		0.40	
16	4-Way 2' x 2' Cassette	TR	9k to 12k		0.55	
17	4-Way 2' x 2' Cassette	TQ	15k to 18k		0.71	
18	4-Way 3' x 3' Cassette	TN	7k to 24k		0.88	
19	4-Way 3' x 3' Cassette	TM	28k to 36k		1.08	
20	4-Way 3' x 3' Cassette	TM	42k to 48k		1.41	
21	High Static Ducted	M1	7k to 24k		0.57	
22	High Static Ducted	M2	7k to 24k		0.77	
23	High Static Ducted	M2	28k to 42k		1.15	
24	High Static Ducted	M3	28k to 54k		1.35	
25	High Static Ducted	B8	36k to 96k		2.20	
26	Low Static Ducted, Low Static Ducted Bottom Return	L1	5k to 9k		0.31	
27	Low Static Ducted, Low Static Ducted Bottom Return	L2	12k to 18k		0.42	
28	Low Static Ducted, Low Static Ducted Bottom Return	L3	21k to 24k		0.55	
29	Vertical / Horizontal Air Handling Unit	NJ	12k to 30k		1.04	
30	Vertical / Horizontal Air Handling Unit	NJ	36k		1.57	
31	Vertical / Horizontal Air Handling Unit	NK	42k to 54k		2.00	
32	Floor Standing	CE (U)	7k to 15k		0.37	
33	Floor Standing	CF (U)	18k to 24k		0.82	
34	HRU: PRHR022A/023A, 032A/033A, 042A/043A	—	—		1.1	
35	HRU: PRHR063A, 083A	—	—		2.2	
36	<b>ADDITIONAL Refrigerant Charge Required (Sum of lines 1 – 35)</b>					
37	Outdoor Unit Factory Refrigerant Charge	37A	ARUM072*TE5	72k		14.3
		37B	ARUM096*TE5	96k		23.2
		37C	ARUM121*TE5	121k		23.2
		37D	ARUM144*TE5	144k		26.5
		37E	ARUM168*TE5	168k		26.5
		37F	ARUM192*TE5	192k		30.9
		37G	ARUM216*TE5	216k		37.5
		37H	ARUM241*TE5	241k		37.5
38	<b>Total ODU FACTORY Refrigerant Charge (Sum of factory refrigerant charges for all ODUs in the system, lines 37A -37H)</b>					
39	<b>TOTAL SYSTEM CHARGE</b>					
	Sum of Additional Refrigerant Charge Required (line 36) and Total ODU Factory Refrigerant Charge (line 37)					

Introduction

<sup>1</sup>CF (Ref.) = Correction Factor for Refrigerant Charge. <sup>2</sup>For refrigerant charge purposes, consider only the liquid line; ignore the vapor line(s).

# REFRIGERANT CHARGE WORKSHEET



Water IV System R410A Refrigerant Charge Calculator (lbs.)

System Tag or ID:		Job Name: _____				
		Project Manager: _____			Date: _____	
Line #	Description	Chassis I.D.	Size	Quantity	CF (Ref.) <sup>1</sup>	Total (lbs.)
1	Linear feet of 1/4" liquid line tubing <sup>2</sup>	—	—		0.015	
2	Linear feet of 3/8" liquid line tubing <sup>2</sup>	—	—		0.041	
3	Linear feet of 1/2" liquid line tubing <sup>2</sup>	—	—		0.079	
4	Linear feet of 5/8" liquid line tubing <sup>2</sup>	—	—		0.116	
5	Linear feet of 3/4" liquid line tubing <sup>2</sup>	—	—		0.179	
6	Linear feet of 7/8" liquid line tubing <sup>2</sup>	—	—		0.238	
7	Linear feet of 1" liquid line tubing <sup>2</sup>	—	—		0.323	
8	Standard + Art Cool Mirror	SJ, SK	5k to 15k		0.53	
9	Standard + Art Cool Mirror	SJ, SK	18k to 24k		0.62	
10	Standard	SV	30k to 36k		1.01	
11	Art Cool Gallery	SF	9k to 12k		0.22	
12	1-Way Cassette	TU	7k to 12k		0.44	
13	1-Way Cassette	TT	18k to 24k		0.64	
14	2-Way Cassette	TS	18k to 24k		0.75	
15	4-Way 2' x 2' Cassette	TR	5k to 7k		0.40	
16	4-Way 2' x 2' Cassette	TR	9k to 12k		0.55	
17	4-Way 2' x 2' Cassette	TQ	15k to 18k		0.71	
18	4-Way 3' x 3' Cassette	TN	7k to 24k		0.88	
19	4-Way 3' x 3' Cassette	TM	28k to 36k		1.08	
20	4-Way 3' x 3' Cassette	TM	42k to 48k		1.41	
21	High Static Ducted	M1	7k to 24k		0.57	
22	High Static Ducted	M2	7k to 24k		0.77	
23	High Static Ducted	M2	28k to 42k		1.15	
24	High Static Ducted	M3	28k to 54k		1.35	
25	High Static Ducted	B8	36k to 96k		2.20	
26	Low Static Ducted, Low Static Ducted Bottom Return	L1	5k to 9k		0.31	
27	Low Static Ducted, Low Static Ducted Bottom Return	L2	12k to 18k		0.42	
28	Low Static Ducted, Low Static Ducted Bottom Return	L3	21k to 24k		0.55	
29	Vertical / Horizontal Air Handling Unit	NJ	12k to 30k		1.04	
30	Vertical / Horizontal Air Handling Unit	NJ	36k		1.57	
31	Vertical / Horizontal Air Handling Unit	NK	42k to 54k		2.00	
32	Floor Standing	CE (U)	7k to 15k		0.37	
33	Floor Standing	CF (U)	18k to 24k		0.82	
34	HRU: PRHR022A/023A, 032A/033A, 042A/043A	—	—		1.1	
35	HRU: PRHR063A, 083A	—	—		2.2	
36	<b>ADDITIONAL Refrigerant Charge Required (Sum of lines 1 – 35)</b>					
37	Water-Source Unit Factory Refrigerant Charge	ARW*072BAS4, ARW*096BAS4, ARW*121BAS4, ARW*144BAS4			10.42	
		ARW*072DAS4, ARW*096DAS4, ARW*121DAS4			10.42	
		ARW*144DAS4, ARW*192DAS4			11.66	
38	<b>Total WSU FACTORY Refrigerant Charge (Sum of factory refrigerant charges for all WSUs in the system)</b>					
39	<b>TOTAL SYSTEM CHARGE</b>					
	Sum of Additional Refrigerant Charge Required (line 36) and Total WSU Factory Refrigerant Charge (line 38)					

<sup>1</sup>CF (Ref.) = Correction Factor for Refrigerant Charge. <sup>2</sup>For refrigerant charge purposes, consider only the liquid line; ignore the vapor line(s).





# REFRIGERANT CHARGE WORKSHEET

Multi V S System R410A Refrigerant Charge Calculator (lbs.)

System Tag or ID:		Job Name: _____				
		Project Manager: _____			Date: _____	
Line #	Description	Chassis I.D.	Size	Quantity	CF (Ref.) <sup>1</sup>	Total (lbs.)
1	Linear feet of 1/4" liquid line tubing <sup>2</sup>	—	—		0.015	
2	Linear feet of 3/8" liquid line tubing <sup>2</sup>	—	—		0.041	
3	Linear feet of 1/2" liquid line tubing <sup>2</sup>	—	—		0.079	
4	Linear feet of 5/8" liquid line tubing <sup>2</sup>	—	—		0.116	
5	Linear feet of 3/4" liquid line tubing <sup>2</sup>	—	—		0.179	
6	Linear feet of 7/8" liquid line tubing <sup>2</sup>	—	—		0.238	
7	Linear feet of 1" liquid line tubing <sup>2</sup>	—	—		0.323	
8	Standard + Art Cool Mirror	SJ, SK	5k to 15k		0.53	
9	Standard + Art Cool Mirror	SJ, SK	18k to 24k		0.62	
10	Standard	SV	30k to 36k		1.01	
11	Art Cool Gallery	SF	9k to 12k		0.22	
12	1-Way Cassette	TU	7k to 12k		0.44	
13	1-Way Cassette	TT	18k to 24k		0.64	
14	2-Way Cassette	TS	18k to 24k		0.75	
15	4-Way 2' x 2' Cassette	TR	5k to 7k		0.40	
16	4-Way 2' x 2' Cassette	TR	9k to 12k		0.55	
17	4-Way 2' x 2' Cassette	TQ	15k to 18k		0.71	
18	4-Way 3' x 3' Cassette	TN	7k to 24k		0.88	
19	4-Way 3' x 3' Cassette	TM	28k to 36k		1.08	
20	4-Way 3' x 3' Cassette	TM	42k to 48k		1.41	
21	High Static Ducted	M1	7k to 24k		0.57	
22	High Static Ducted	M2	7k to 24k		0.77	
23	High Static Ducted	M2	28k to 42k		1.15	
24	High Static Ducted	M3	28k to 54k		1.35	
25	High Static Ducted	B8	36k to 96k		2.20	
26	Low Static Ducted, Low Static Ducted Bottom Return	L1	5k to 9k		0.31	
27	Low Static Ducted, Low Static Ducted Bottom Return	L2	12k to 18k		0.42	
28	Low Static Ducted, Low Static Ducted Bottom Return	L3	21k to 24k		0.55	
29	Vertical / Horizontal Air Handling Unit	NJ	12k to 30k		1.04	
30	Vertical / Horizontal Air Handling Unit	NJ	36k		1.57	
31	Vertical / Horizontal Air Handling Unit	NK	42k to 54k		2.00	
32	Floor Standing	CE (U)	7k to 15k		0.37	
33	Floor Standing	CF (U)	18k to 24k		0.82	
34	HRU: PRHR022A/023A, 032A/033A, 042A/043A	—	—		1.1	
35	HRU: PRHR063A, 083A	—	—		2.2	
36	<b>ADDITIONAL Refrigerant Charge Required (Sum of lines 1 – 35)</b>					
37	Total Outdoor Unit Factory Refrigerant Charge (Choose One)	37A	ARUN024GSS4		0	
		37B	ARUN038GSS4		0	
		37C	ARUN048GSS4		0	
		37D	ARUN053GSS4		0	
		37E	ARUN060GSS4		0	
		37F	ARUB060GSS4		0	
38	<b>TOTAL SYSTEM CHARGE</b>					
Sum of Additional Refrigerant Charge Required (line 36) and Total ODU Factory Refrigerant Charge (from line 37A to 35F)						

<sup>1</sup>CF (Ref.) = Correction Factor for Refrigerant Charge. <sup>2</sup>For refrigerant charge purposes, consider only the liquid line; ignore the vapor line(s).



# ONE-WAY CEILING CASSETTE



**Mechanical Specifications on page 12**

**General Data on page 14**

**Electrical Data on page 16**

**External Dimensions on page 17**

**Electrical Wiring Diagrams on page 19**

**Refrigerant Flow Diagrams on page 21**

**Acoustic Data on page 22**

**Air Velocity / Temperature Distribution on page 26**

**Fresh Air Ventilation on page 34**

**Capacity Tables on page 35**

**Optional Accessories on page 40**

# ONE-WAY CEILING CASSETTE



## Mechanical Specifications

### Casing

The case is designed to mount recessed in the ceiling and has a surface-mounted concentric grille on the bottom of the unit. The unit case is manufactured with coated metal. Cold surfaces are covered with a coated polystyrene insulating material. The case is provided with metal ears designed to support the unit weight on four corners. Ears have pre-punched holes designed to accept field-supplied all-thread rod hangers.

### Ventilation Air

The case has a factory designated cutout for the connection of a field-supplied outside air duct and flange.

### Architectural Filter/Grille

The ceiling cassette assembly is provided with an off-white ABS polymeric resin architectural grille with a tapered trim edge and a hinged, spring clip (screw-less) return air filter-grille door.

### Fan Assembly and Control

The indoor unit has a single, direct-drive, cross-flow tangential Sirocco fan made of high strength ABS GP-2305 polymeric resin. The fan motor is a Brushless Digitally Controlled (BLDC) design with permanently lubricated and sealed ball bearings. The fan motor includes thermal, overcurrent and low RPM protection. The fan / motor assembly is mounted on vibration attenuating rubber grommets. The fan impeller is statically and dynamically balanced. The fan speed is controlled using a microprocessor-based control algorithm that provides a high fan speed in cooling thermal ON and low fan speed in cooling thermal OFF, high fan speed in heating thermal ON and fan off in heating thermal OFF. The fan speeds can be field adjusted between low, medium, and high speeds. The fan speed algorithm provides a field-selectable fixed-speed or auto-speed setting that adjusts the fan speed to simulate natural airflow.

### Air Filter

Return air is filtered with a removable, washable filter with anti-fungal treatment. Plasma filter accessories are also available separately.

### Airflow Guide Vanes

The architectural grille has a single directional slot diffuser with an oscillating motorized guide vane designed to change the angle airflow is discharged. The discharge range of motion is 40° in an up/down direction with the capability of locking the vanes in a field adjusted fixed position.

### Microprocessor Controls

The unit is provided with an integrated microprocessor controller capable of performing functions necessary to operate the system without the use of a wall-mounted controller. A temperature thermistor is factory-mounted in the return air stream. All unit operation parameters, excluding the operation schedule, are stored in non-volatile memory resident on the unit microprocessor.



Operating schedules are stored in select models of the optional, wall-mounted, local, or central controller. The field-supplied communication cable between the indoor unit(s) and outdoor unit is to be a minimum of 18 AWG, 2 conductor, twisted, stranded, and shielded cable (RS-485), terminated via screw terminals on the control boards. The microprocessor control provides the following functions: auto addressing, self-diagnostics, auto restart following power restoration, test run, and will operate the indoor unit using one of five operating modes:

1. Auto Changeover (Heat Recovery only)
2. Heating
3. Cooling
4. Dry
5. Fan Only

For Heat Recovery systems the Auto Changeover setting automatically switches control of the indoor unit between Cooling and Heating modes based on space temperature conditions.

For Heat Pump systems, heated or cooled air delivery is dependent upon outdoor unit operating mode.

In Heating mode, the microprocessor control will activate indoor unit operation when the indoor room temperature falls below set-point temperature. At which point, a signal is sent to the outdoor unit to begin the heating cycle. The indoor unit fan operation is delayed until coil pipe temperature reaches 76°F. Significant airflow is generated when pipe temperature reaches 80°F. The unit is equipped with an infrared receiver designed to communicate with an LG wireless remote controller. In lieu of wireless remote or factory return air thermistor, screw terminals on the microprocessor circuit board accommodate various models of wall-mounted local controllers and/or a wall-mounted remote temperature sensor. The unit microprocessor is capable of accepting space temperature readings concurrently or individually from either:

1. Wall-mounted wired controller(s)
2. Factory mounted return air thermistor or the optional wall-mounted wired remote temperature sensor

A single indoor unit has the capability of being controlled by up to two local wired controllers. The microprocessor controls space temperature using the value provided by the temperature sensor sensing a space temperature that is farthest away from the temperature set-point. The microprocessor control provides a cooling or heating

mode test cycle that operates the unit for 18 minutes without regard to the space temperature. If the system is provided with an optional wall-mounted local or central controller, displayed diagnostic codes are specific, alpha-numeric, and provide the service technician with a reason for the code displayed.

Indoor units are Wi-Fi compatible with the addition of an LG Wi-Fi module accessory, and can be controlled by LG's Smart ThinQ™ app on a smart device. A field-supplied Wi-Fi network and smart device are required. The Smart ThinQ app is free, and is available for Android™ and iOS. (Android is a trademark of Google LLC.)

### Condensate Lift/Pump

The indoor unit comes with a factory installed and wired condensate lift/pump capable of providing a maximum 27.5 inch lift from the bottom surface of the unit. The lift pump comes with a safety switch that shuts off the indoor unit if condensate rises too high in the drain pan.

### Condensate Drain Pan

The condensate drain pan is constructed of EPS (expandable polystyrene resin).

### Coil

The indoor unit coil is constructed with grooved design copper tubes with slit coil fins, two (2) rows, twenty-one (21) fins per inch.

### Controls Features

- Auto changeover (Heat Recovery only)
- Auto operation / auto restart
- External on / off control
- Dual thermistor control
- Dual setpoint control
- Filter life display
- Multiple auxiliary heater applications
- Group control
- High ceiling
- Hot start
- Self diagnostics
- Timer (on / off)
- Weekly schedule
- Auto direction/swing (up/down)
- Fan speed control
- Jet cool (fast cooling)
- Wi-Fi compatible
- Auto fan
- Leak detection

*\*To enable Generation 4 features, outdoor unit DIP Switch No. 3 must be set to ON. Please refer to the Multi V 5, Multi V IV, Multi V Water IV, Multi V S Engineering Manual for additional information.*

# ONE-WAY CEILING CASSETTE



## General Data

Table 1: One-Way Ceiling Cassette (TU Frames) Indoor Unit General Data.

Model No.	ARNU073TUD4	ARNU093TUD4	ARNU123TUD4
<i>Cooling Mode Performance</i>			
Capacity (Btu/h)	7,500	9,600	12,300
Max Power Input <sup>1</sup> (W)	40	40	40
L/M/H Power Input at Factory Default (W)	16 / 18 / 20	18 / 20 / 22	20 / 22 / 24
<i>Heating Mode Performance</i>			
Capacity (Btu/h)	8,500	10,900	13,600
Max Power Input <sup>1</sup> (W)	40	40	40
L/M/H Power Input at Factory Default (W)	16 / 18 / 20	18 / 20 / 22	20 / 22 / 24
<i>Entering Mixed Air</i>			
Cooling Max (°F WB)	76	76	76
Heating Min (°F DB)	59	59	59
<i>Unit Data</i>			
Refrigerant Type <sup>2</sup>	R410A	R410A	R410A
Refrigerant Control	EEV	EEV	EEV
Sound Pressure <sup>3</sup> dB(A) (H/M/L)	32 / 29 / 25	35 / 34 / 32	38 / 35 / 32
Net Unit Weight (lbs.)	33	33	33
Shipping Weight (lbs.)	40	40	40
Grille Weight (lbs)	10	10	10
Grille Shipping Weight (lbs)	16	16	16
Communication Cable <sup>4</sup> (No. x AWG)	2 x 18	2 x 18	2 x 18
<i>Fan</i>			
Type	Cross Flow	Cross Flow	Cross Flow
Quantity	1	1	1
Motor/Drive	Brushless Digitally Controlled / Direct		
Airflow Rate H/M/L (CFM)	290 / 258 / 226	325 / 304 / 290	353 / 325 / 290
<i>Piping</i>			
Liquid Line (in., O.D.)	1/4 Flare	1/4 Flare	1/4 Flare
Vapor Line (in., O.D.)	1/2 Flare	1/2 Flare	1/2 Flare
Condensate Line (in., I.D.)	1	1	1

EEV: Electronic Expansion Valve

Power wiring is field supplied and must comply with the applicable local and national codes. See page 12 for detailed electrical data.

This unit comes with a dry nitrogen charge.

All capacities are net with a combination ratio between 95-105%.

Rated capacity is certified under AHRI Standard 1230. Ratings are subject to change without notice. Current certified ratings are available at [www.ahridirectory.org](http://www.ahridirectory.org).

Low ambient performance with LGRED® heat technology is included in Multi V 5 air source units produced after February 2019.

<sup>1</sup>Max power input is rated at maximum setting value.

<sup>2</sup>Take appropriate actions at the end of HVAC equipment life to recover, recycle, reclaim or destroy R410A refrigerant according to applicable regulations (40 CFR Part 82, Subpart F) under section 608 of CAA.

<sup>3</sup>Sound Pressure levels are tested in an anechoic chamber under ISO Standard 3745.

<sup>4</sup>Communication cable between Master ODU to IDUs / HRUs to be 18 AWG, 2-conductor, twisted, stranded, shielded. Ensure the communication cable shield is properly grounded to the Master ODU chassis only. ⚠ Do not ground the ODU to IDUs / HRUs communication cable at any other point. Wiring must comply with all applicable local and national codes.

Table 2: One-Way Ceiling Cassette (TT Frames) Indoor Unit General Data.

Model No.	ARNU183TTD4	ARNU243TTD4
<i>Cooling Mode Performance</i>		
Capacity (Btu/h)	19,100	24,200
Max Power Input <sup>1</sup> (W)	70	70
L/M/H Power Input at Factory Default (W)	24 / 28 / 38	26 / 33 / 51
<i>Heating Mode Performance</i>		
Capacity (Btu/h)	21,500	24,200
Max Power Input <sup>1</sup> (W)	70	70
L/M/H Power Input at Factory Default (W)	24 / 28 / 38	26 / 33 / 51
<i>Entering Mixed Air</i>		
Cooling Max (°F WB)	76	76
Heating Min (°F DB)	59	59
<i>Unit Data</i>		
Refrigerant Type <sup>2</sup>	R410A	R410A
Refrigerant Control	EEV	EEV
Sound Pressure <sup>3</sup> dB(A) (H/M/L)	40 / 37 / 35	43 / 40 / 36
Net Unit Weight (lbs.)	42	42
Shipping Weight (lbs.)	49	49
Grille Weight (lbs)	13	13
Grille Shipping Weight (lbs)	20	20
Communication Cable <sup>4</sup> (No. x AWG)	2 x 18	2 x 18
<i>Fan</i>		
Type	Cross Flow	Cross Flow
Quantity	1	1
Motor/Drive	Brushless Digitally Controlled / Direct	
Airflow Rate H/M/L (CFM)	470 / 427 / 385	515 / 470 / 406
<i>Piping</i>		
Liquid Line (in., O.D.)	1/4 Flare	3/8 Flare
Vapor Line (in., O.D.)	1/2 Flare	5/8 Flare
Condensate Line (in., I.D.)	1	1

EEV: Electronic Expansion Valve

Power wiring is field supplied and must comply with the applicable local and national codes. See page 12 for detailed electrical data.

This unit comes with a dry nitrogen charge.

All capacities are net with a combination ratio between 95-105%.

Rated capacity is certified under AHRI Standard 1230. Ratings are subject to change without notice. Current certified ratings are available at [www.ahridirectory.org](http://www.ahridirectory.org).

Low ambient performance with LGRED<sup>®</sup> heat technology is included in Multi V 5 air source units produced after February 2019.

<sup>1</sup>Max power input is rated at maximum setting value.

<sup>2</sup>Take appropriate actions at the end of HVAC equipment life to recover, recycle, reclaim or destroy R410A refrigerant according to applicable regulations (40 CFR Part 82, Subpart F) under section 608 of CAA.

<sup>3</sup>Sound Pressure levels are tested in an anechoic chamber under ISO Standard 3745.

<sup>4</sup>Communication cable between Master ODU to IDUs / HRUs to be 18 AWG, 2-conductor, twisted, stranded, shielded. Ensure the communication cable shield is properly grounded to the Master ODU chassis only. ⚡ Do not ground the ODU to IDUs / HRUs communication cable at any other point. Wiring must comply with all applicable local and national codes.

# ONE-WAY CEILING CASSETTE



## Electrical Data

Table 3: One-Way Ceiling Cassette Indoor Unit Electrical Data.

Model Number	Voltage Range	MCA	MOP	Rated Amps (A)	Power Supply			Power Input (W)		
					Hz	Volts	Phase	Max Cooling	Max Heating	L/M/H at Factory Default
<i>TU Frames</i>										
ARNU073TUD4	187-253	0.23	15	0.18	60	208-230	1	40	40	16 / 18 / 20
ARNU093TUD4		0.23		0.18				40	40	18 / 20 / 22
ARNU123TUD4		0.23		0.18				40	40	20 / 22 / 24
<i>TT Frames</i>										
ARNU183TTD4	187-253	0.38	15	0.30	60	208-230	1	70	70	24 / 28 / 38
ARNU243TTD4		0.38		0.30				70	70	26 / 33 / 51

MCA : Minimum Circuit Ampacity.

MOP : Maximum Overcurrent Protection.

Units are suitable for use on an electrical system where voltage supplied to unit terminals is within the listed range limits.

Select wire size based on the larger MCA value.

Instead of fuse, use circuit breaker.

Max. power input is rated at maximum setting value



Figure 3: ARNU073TUD4, ARNU093TUD4, ARNU123TUD4 Dimensions (PT-UUC1 Grille).

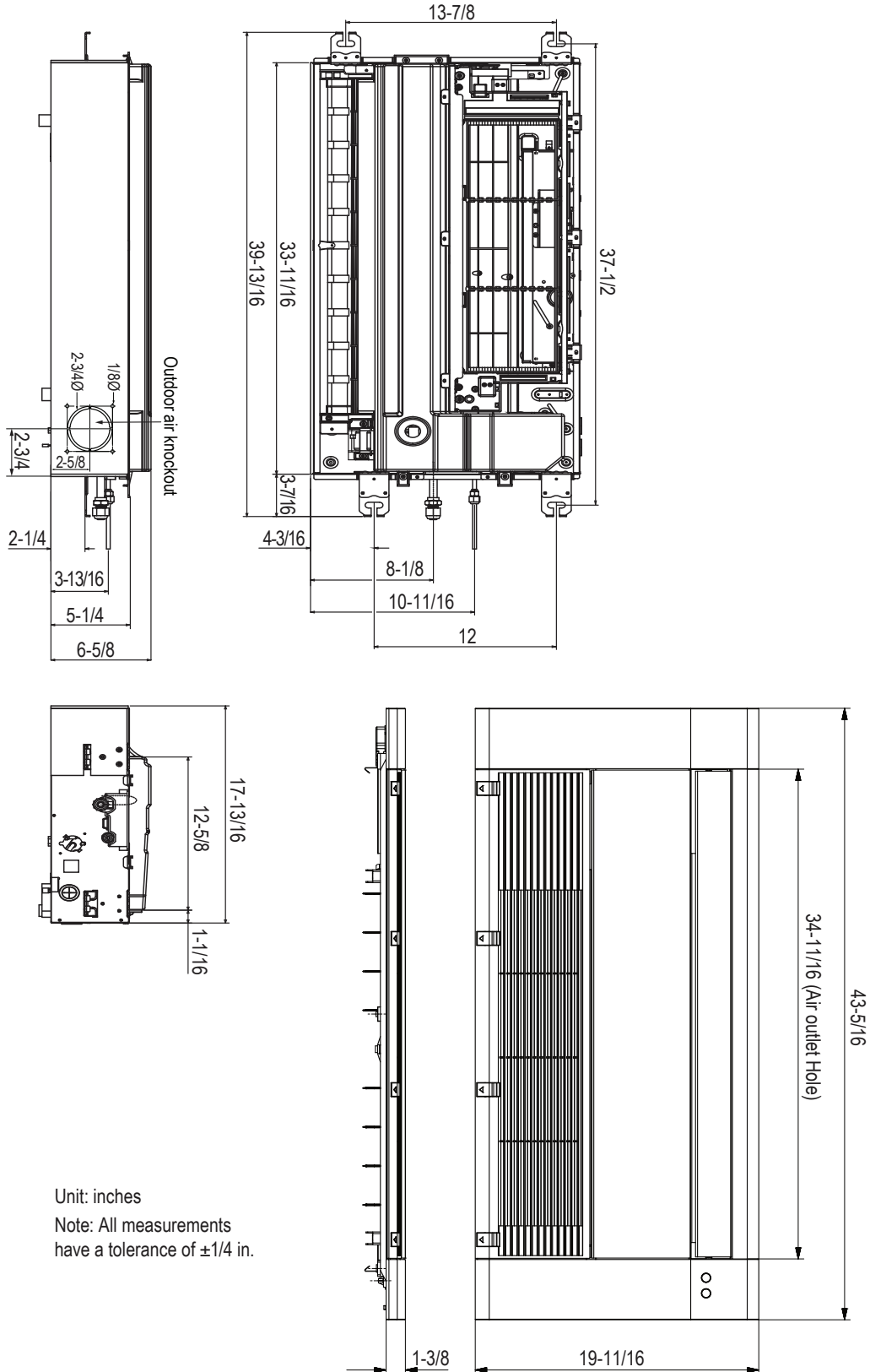

Unit: inches  
Note: All measurements have a tolerance of ±1/4 in.

# ONE-WAY CEILING CASSETTE



External Dimensions

TT Frame with PT-UTC Grille

Figure 4: ARNU183TTD4, ARNU243TTD4 Dimensions (PT-UTC Grille).

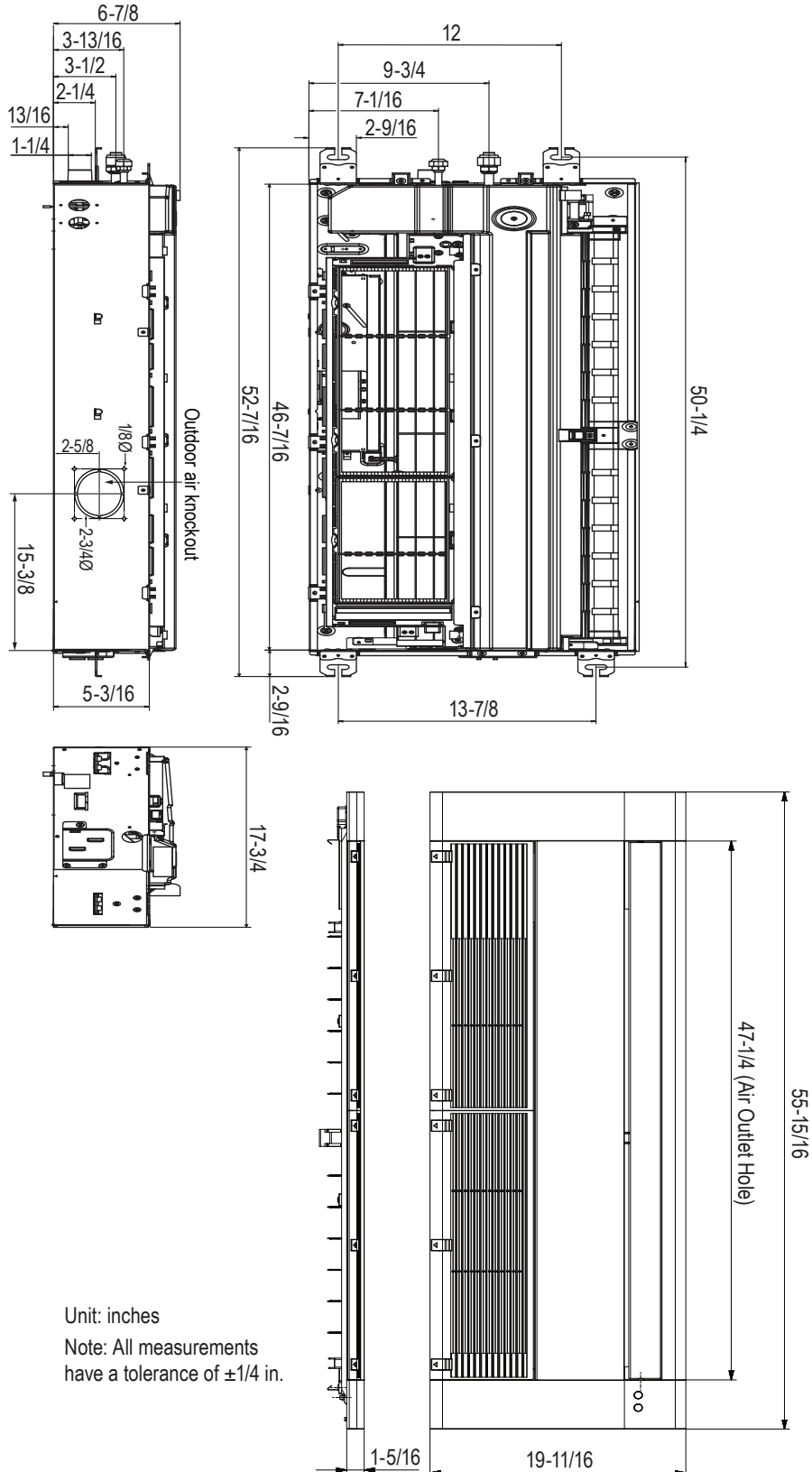

Unit: inches  
 Note: All measurements have a tolerance of  $\pm 1/4$  in.

Figure 5: TU, TT Frame Wiring Diagram.

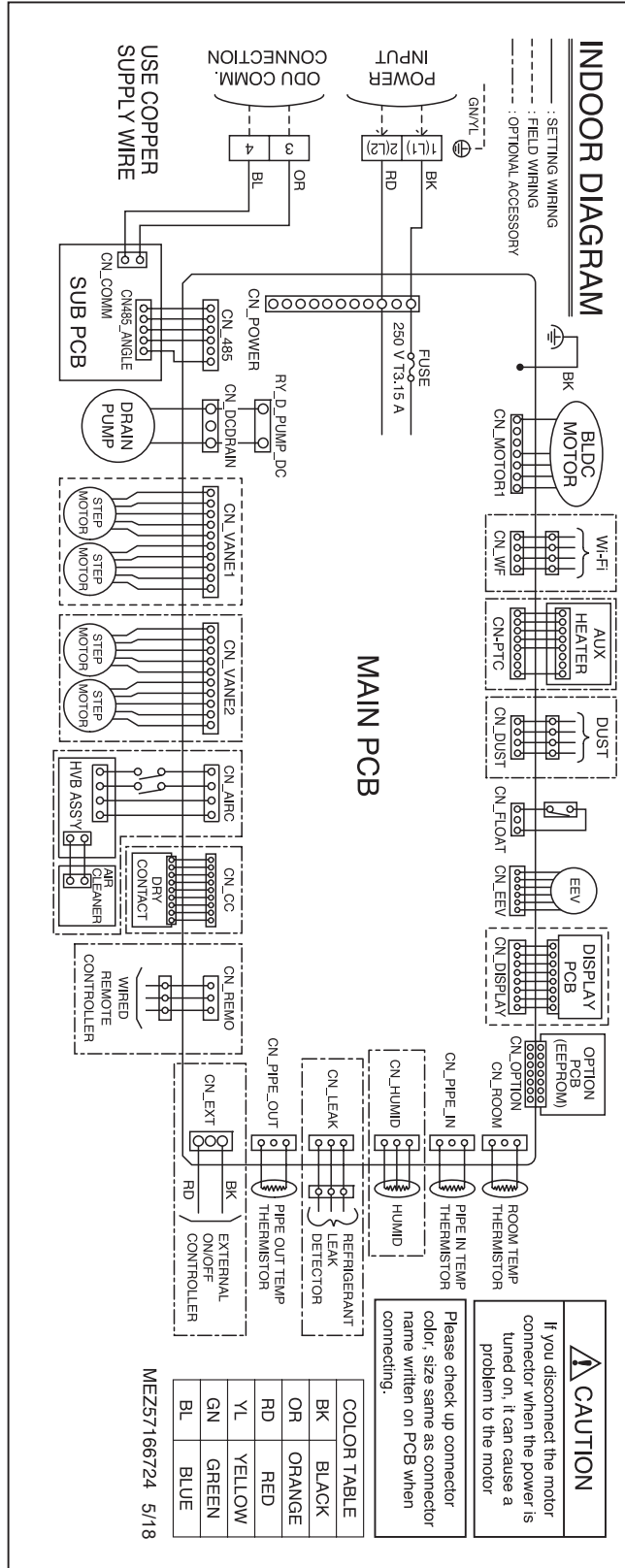

# ONE-WAY CEILING CASSETTE



## Electrical Wiring Diagram TU and TT Frames

Table 4: TU, TT Frame Wiring Diagram Legend.

Terminal	Purpose	Function
CN_MOTOR1	Fan motor output	Motor output of BLDC
CN_WF	Wi-Fi module	Wi-Fi module connection
CN-PTC	Auxiliary heater	Auxiliary heater connection
CN_DUST	N/A	N/A
CN_FLOAT	Float switch input	Float switch sensing
CN_EEV	EEV output	EEV control output
CN_DISPLAY	Display	Display of indoor status
CN_OPTION	Option PCB (EEPROM)	Option PCB connection
CN_ROOM	Room sensor	Room air thermistor
CN_PIPE_IN	Suction pipe sensor	Pipe in thermistor
CN_HUMID	N/A	N/A
CN_LEAK	Leak sensor	Leak sensor connection
CN_PIPE_OUT	Discharge pipe sensor	Pipe out thermistor
CN_EXT	External on/off controller	External on/off controller connection
CN_REMO	Remote controller	Remote control connection
CN_CC	Dry Contact	Connection to Dry Contact (Optional)
CN_AIRC	Air cleaner	Air cleaner control
CN_VANE2	Step Motor	Step motor output
CN_VANE1	Step Motor	Step motor output
CN_DCDRAIN	Drain pump output	AC output for drain pump
CN_485	Communication	Connection between indoor and outdoor units
CN_COMM	Communication	Connection on Sub PCB between indoor and outdoor units
CN_POWER	AC Power supply	AC power line input for indoor controller

Table 5: TU, TT Frame DIP Switch Settings.

DIP Switch Setting		Off	On	Remarks
SW3	GROUP CONTROL	Master	Slave	Group control setting using 7-Day Programmable Controller; selects Master/ Slave on each indoor unit
SW4	DRY CONTACT MODE	Variable	Auto	Sets operation mode for optional Dry Contact accessory 1. Variable: Auto or Manual Mode can be set through 7-Day Programmable Controller or Wireless Remote Controller (factory default setting is Auto if there is no setting) 2. Auto: For Dry Contact, it is always Auto mode

**\*For Gen 4 Multi V one-way ceiling cassette indoor units, DIP switches 1, 2, 5 through 8 must be set to OFF. These DIP switches are used for other models.**

**\*\*To enable Generation 4 features, outdoor unit DIP switch no. 3 must be set to ON. Please refer to the Multi V 5, Multi V IV, Multi V Water IV, Multi V S Engineering Manual for additional information.**

Figure 6: TU, TT Frame Piping Diagram.

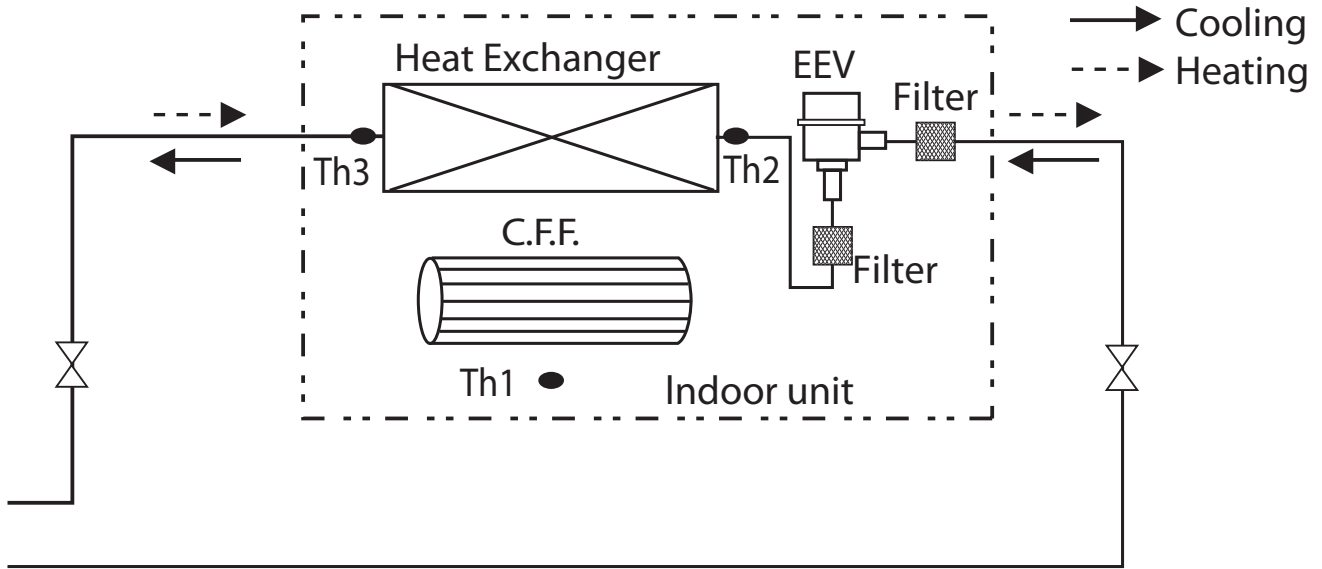

Table 6: TU, TT Frame Refrigerant Pipe Connection Port Diameters.

Model	Liquid (inch)	Gas (inch)
<i>TU Frames</i>		
ARNU073TUD4	1/4	1/2
ARNU093TUD4		
ARNU123TUD4		
<i>TT Frames</i>		
ARNU183TTD4	1/4	1/2
ARNU243TTD4	3/8	5/8

Table 7: TU, TT Frame Thermistors.

Thermistor	Description
TH1	Return air thermistor
TH2	Pipe in thermistor
TH3	Pipe out thermistor

# ONE-WAY CEILING CASSETTE



## Acoustic Data

### Sound Pressure Levels

Figure 7: Sound Pressure Measurement Location.

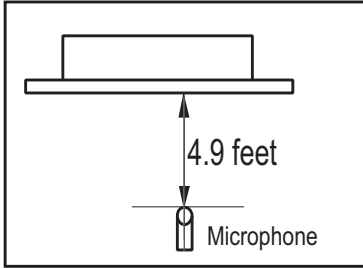

- Measurements are taken 4.9 ft away from the front of the unit.
  - Sound pressure levels are measured in dB(A) with a tolerance of  $\pm 3$ .
  - Sound pressure levels are tested in an anechoic chamber under ISO Standard 3745.
- Operating Conditions:
- Power source: 220V/60 Hz
  - Sound level will vary depending on a range of factors including the construction (acoustic absorption coefficient) of a particular room in which the unit was installed.

Table 8: One-Way Ceiling Cassette Indoor Unit Sound Pressure Levels.

Model	Sound Levels dB(A)		
	High Fan Speed	Medium Fan Speed	Low Fan Speed
<b>TU Frames</b>			
ARNU073TUD4	32.0	29.0	25.0
ARNU093TUD4	35.0	34.0	32.0
ARNU123TUD4	38.0	35.0	32.0
<b>TT Frames</b>			
ARNU183TTD4	40.0	37.0	35.0
ARNU243TTD4	43.0	40.0	36.0

Figure 8: ARNU073TUD4, ARNU093TUD4, and ARNU123TUD4 Sound Pressure Level Diagrams.

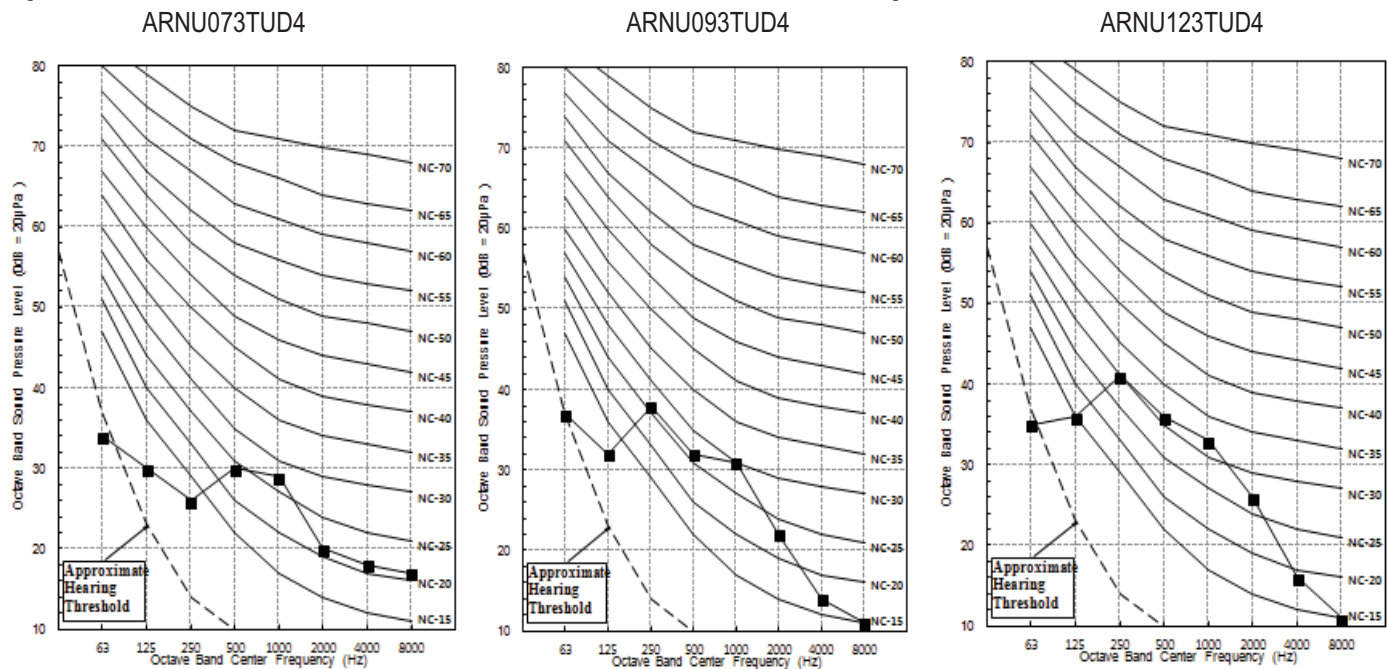
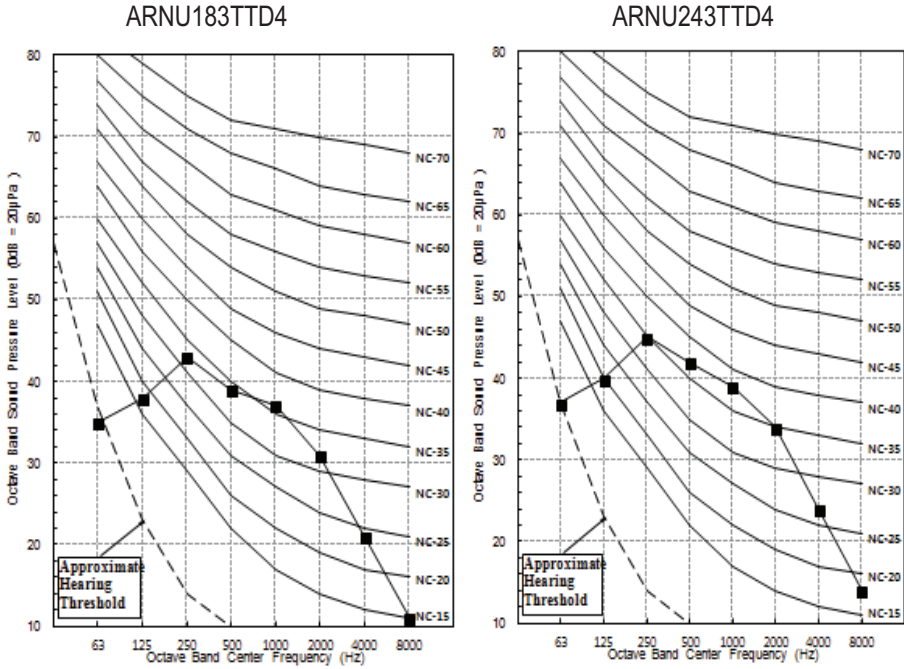

Figure 9: ARNU183TTD4 and ARNU243TTD4 Sound Pressure Level Diagrams.



# ONE-WAY CEILING CASSETTE



## Acoustic Data

### Sound Power Levels

Table 9: One-Way Ceiling Cassette Indoor Unit Sound Power Levels.

Model	Sound Power Levels dB(A)
	High Fan Speed
<b>TU Frames</b>	
ARNU073TUD4	50.0
ARNU093TUD4	53.0
ARNU123TUD4	57.0
<b>TT Frames</b>	
ARNU183TTD4	59.0
ARNU243TTD4	62.0

- Data is valid under diffuse field conditions.
- Data is valid under nominal operating conditions.
- Sound power level is measured using rated conditions, and tested in a reverberation room per ISO 3741 standards.
- Sound level will vary depending on a range of factors such as construction (acoustic absorption coefficient) of particular area in which the equipment is installed.
- Reference acoustic intensity: 0dB = 10E-6μW/m<sup>2</sup>.

Figure 10: ARNU073TUD4, ARNU093TUD4, and ARNU123TUD4 Sound Power Level Diagrams.

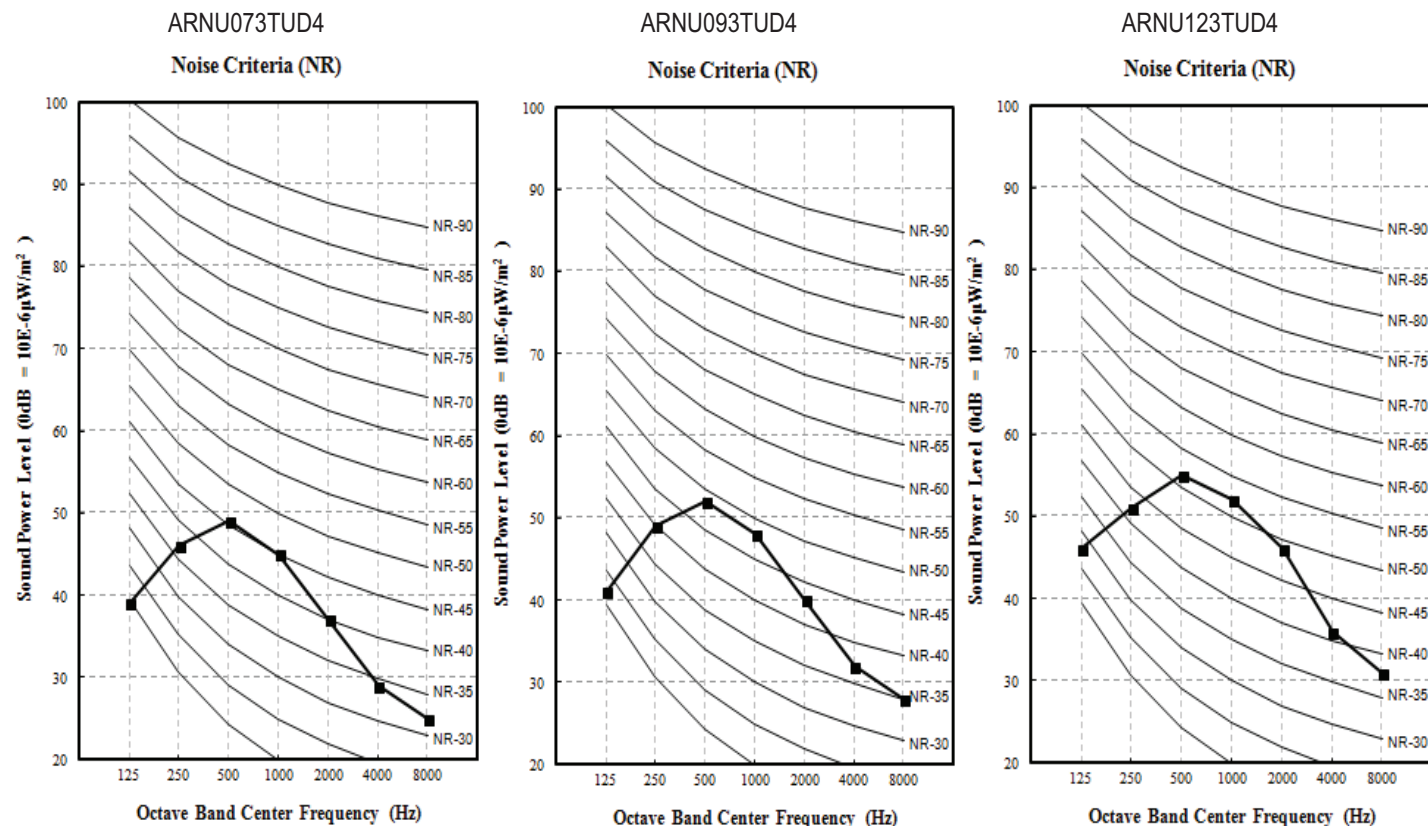
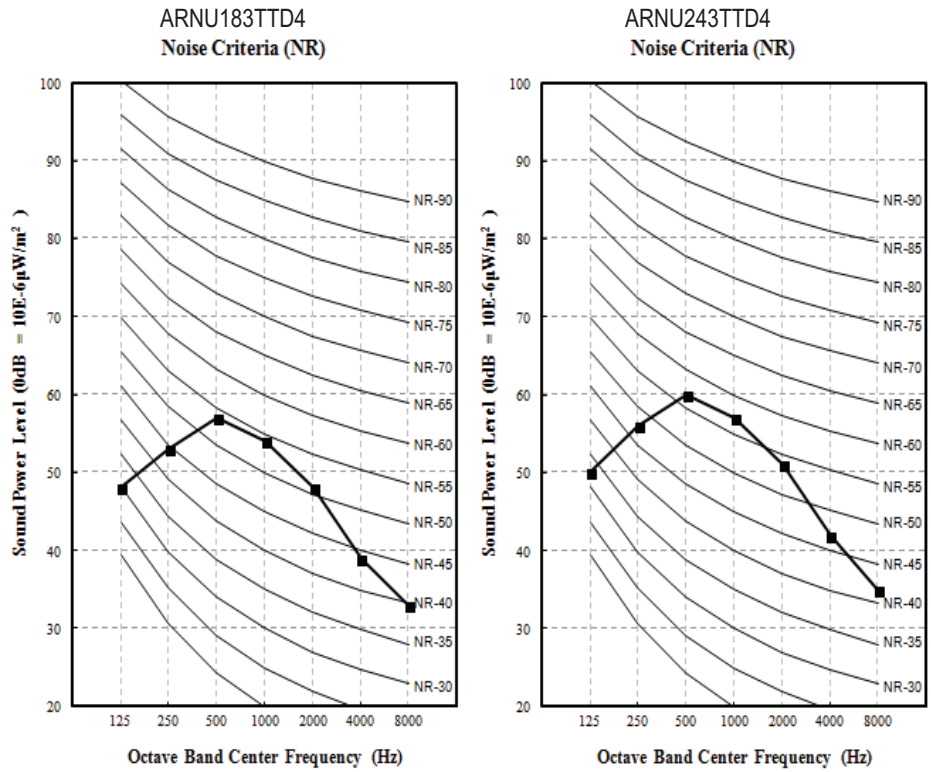



Figure 11: ARNU183TTD4 and ARNU243TTD4 Sound Power Level Diagrams.



# ONE-WAY CEILING CASSETTE



## Air Velocity / Temperature Distribution ARNU073TUD4

Figure 12: ARNU073TUD4.

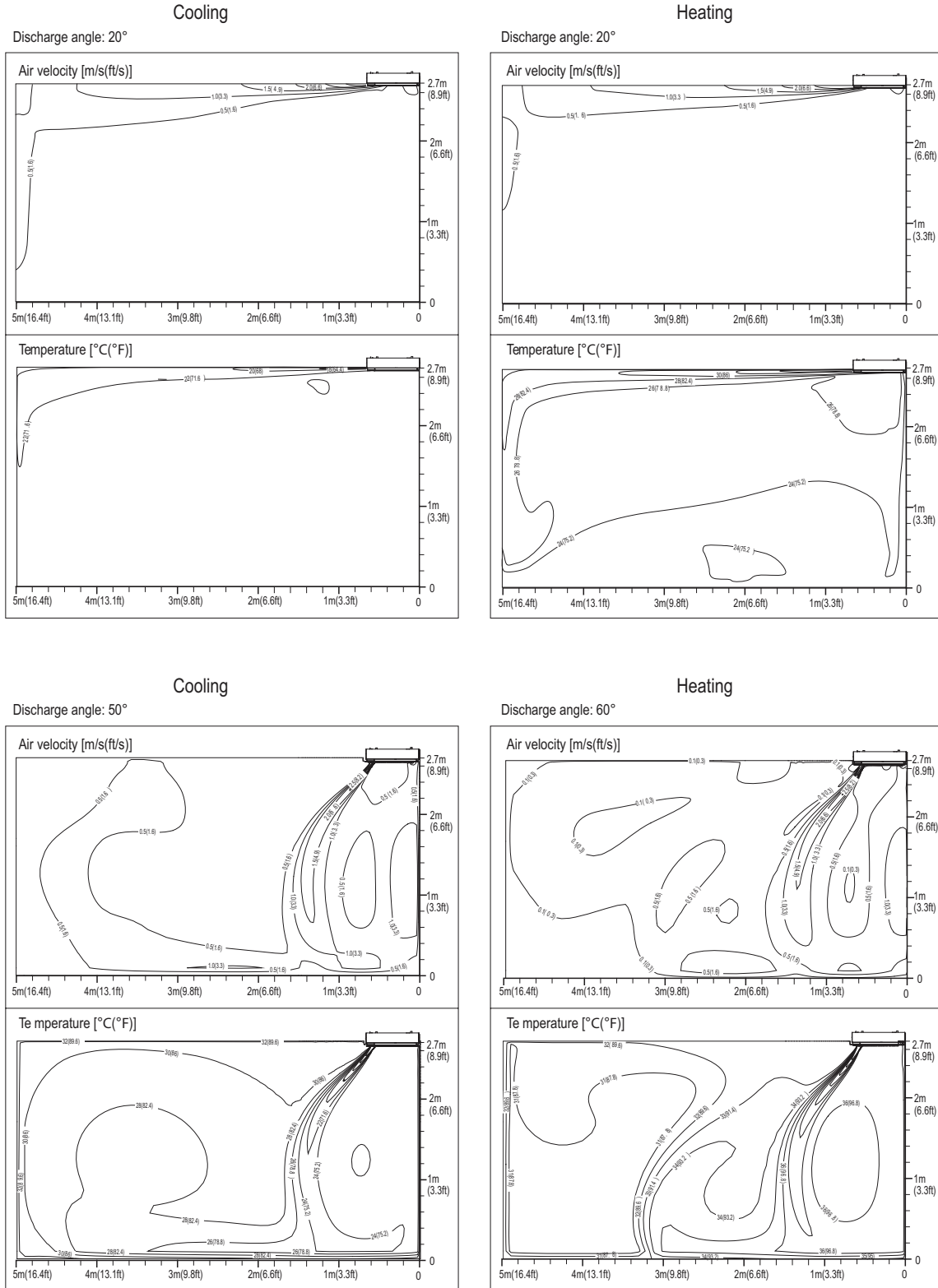

The standard setup height is 8.9 ft. The charts above show the measurement distribution at the ceiling height of 8.9 ft with a high fan operating mode.

Figure 13: ARNU073TUD4, continued.

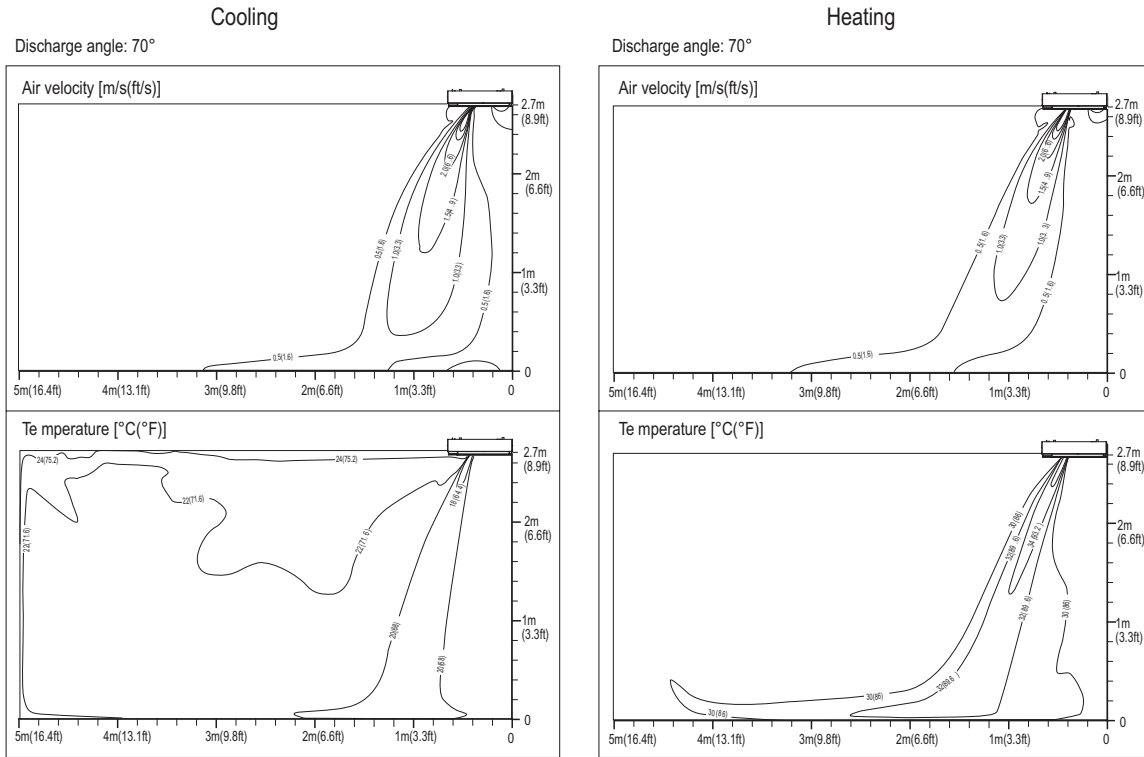
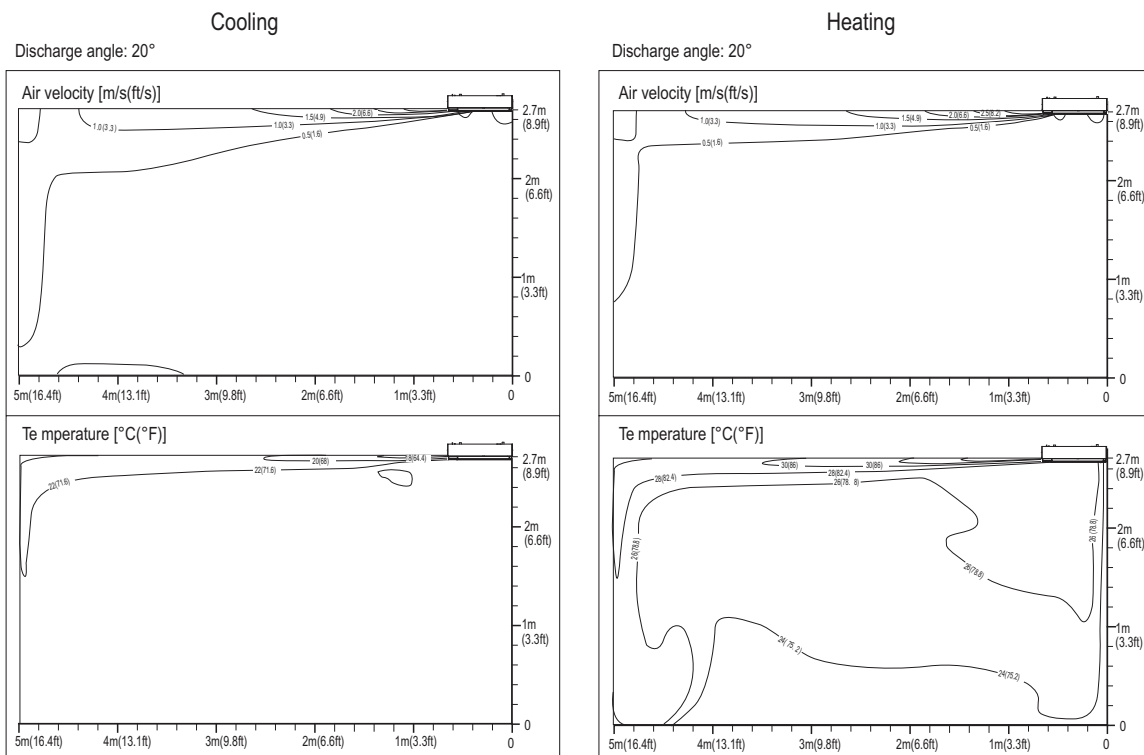

Figure 14: ARNU093TUD4.



The standard setup height is 8.9 ft. The charts above show the measurement distribution at the ceiling height of 8.9 ft with a high fan operating mode.

# ONE-WAY CEILING CASSETTE



## Air Velocity / Temperature Distribution

### ARNU093TUD4

Figure 15: ARNU093TUD4, continued.

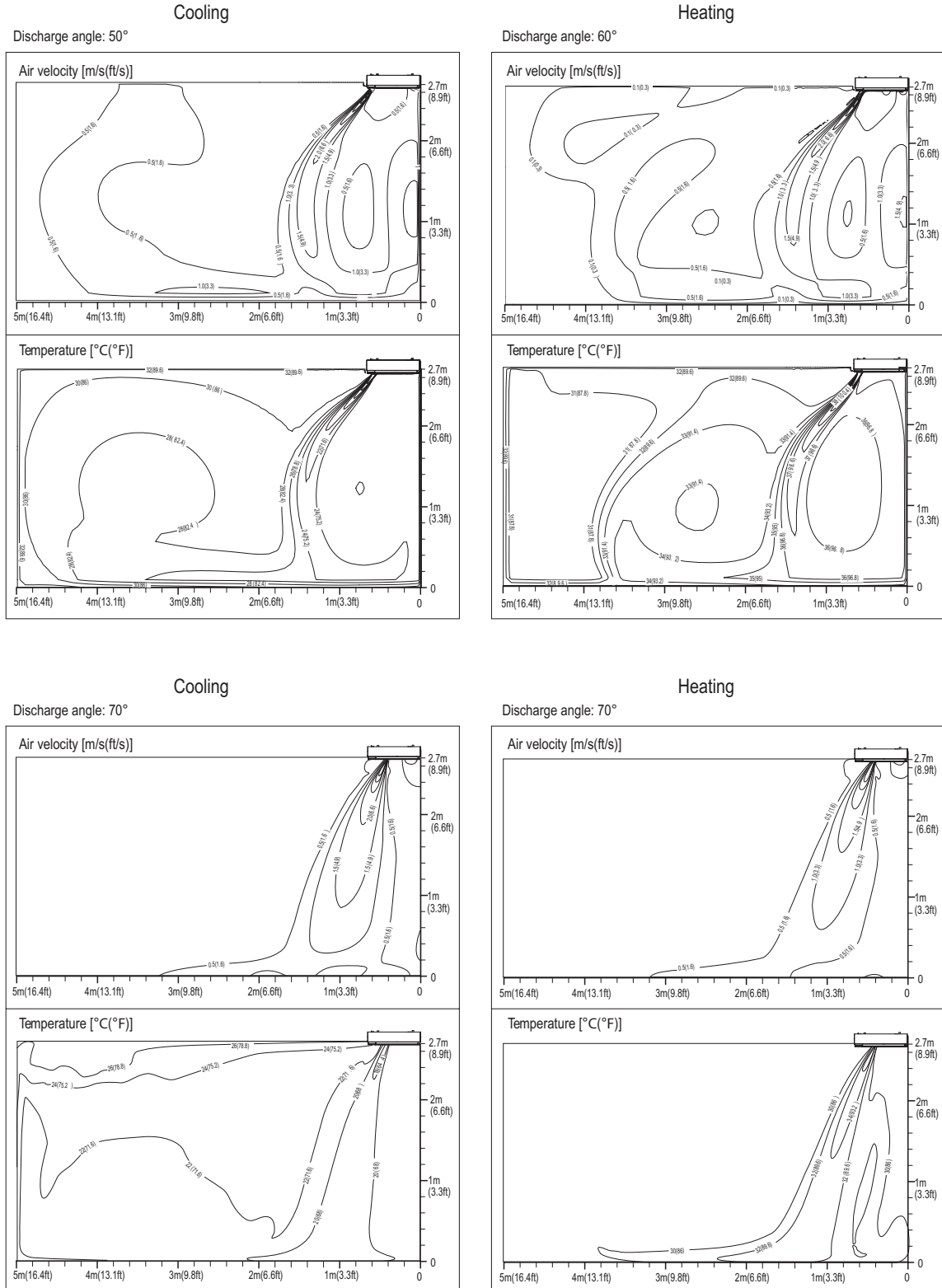

The standard setup height is 8.9 ft. The charts above show the measurement distribution at the ceiling height of 8.9 ft with a high fan operating mode.

Figure 16: ARNU123TUD4.

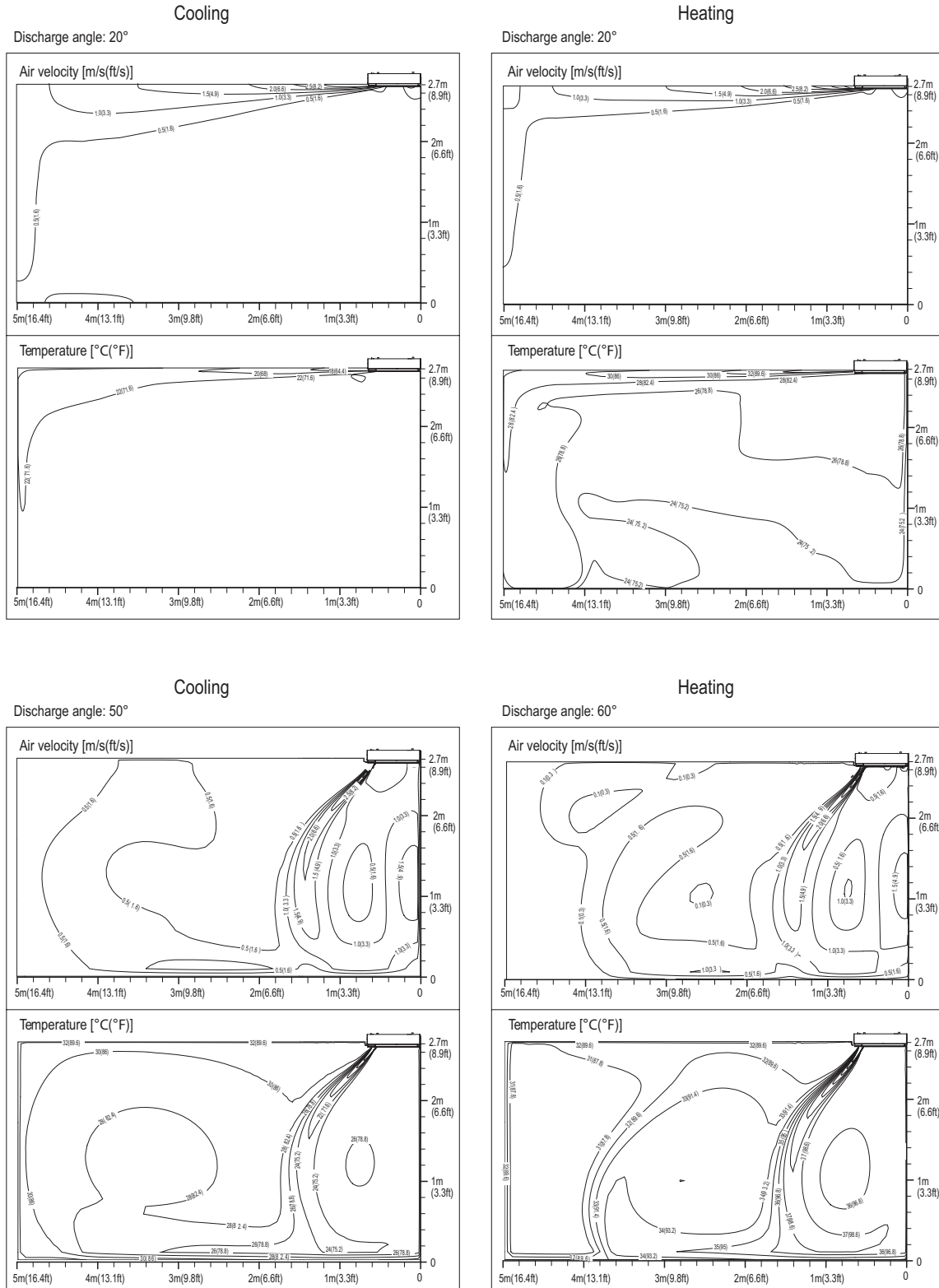

The standard setup height is 8.9 ft. The charts above show the measurement distribution at the ceiling height of 8.9 ft with a high fan operating mode.

# ONE-WAY CEILING CASSETTE



## Air Velocity / Temperature Distribution ARNU123TUD4, ARNU183TTD4

Figure 17: ARNU123TUD4, continued.

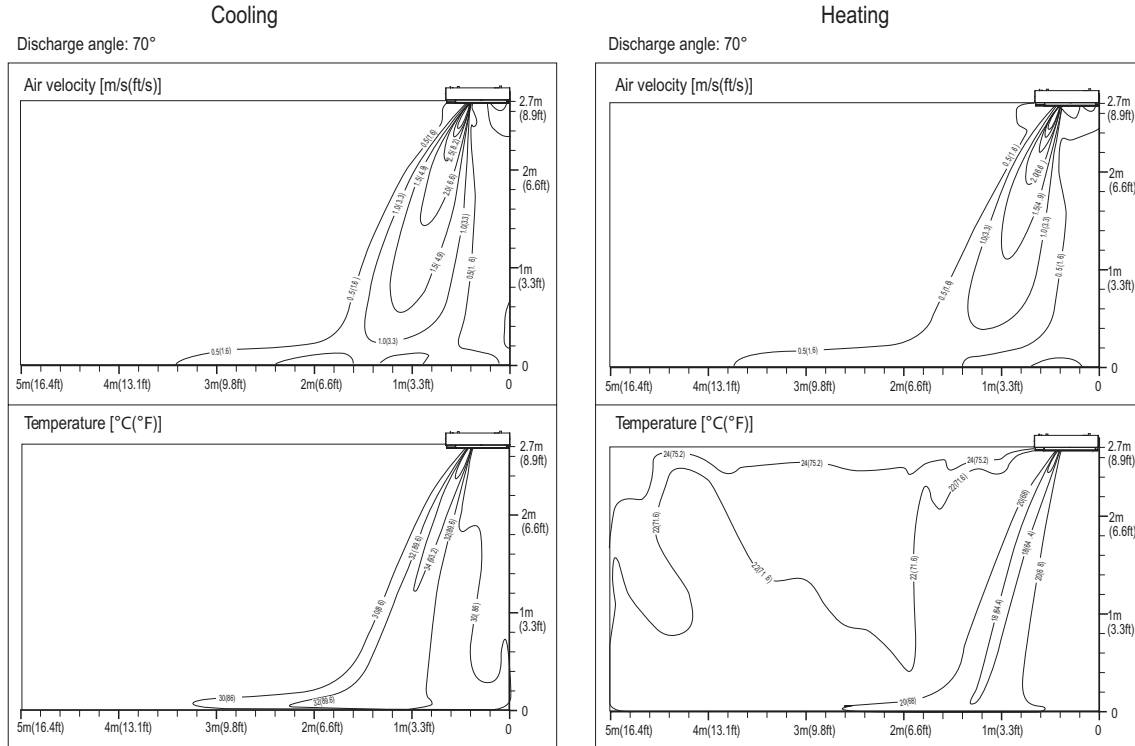
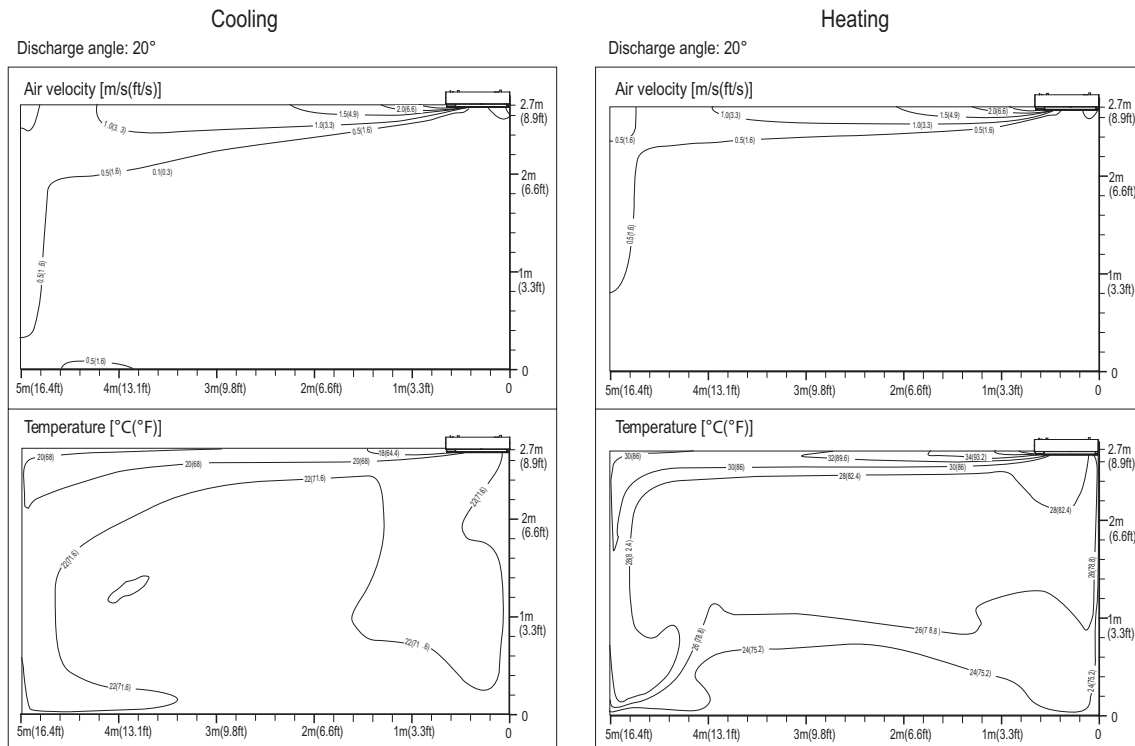
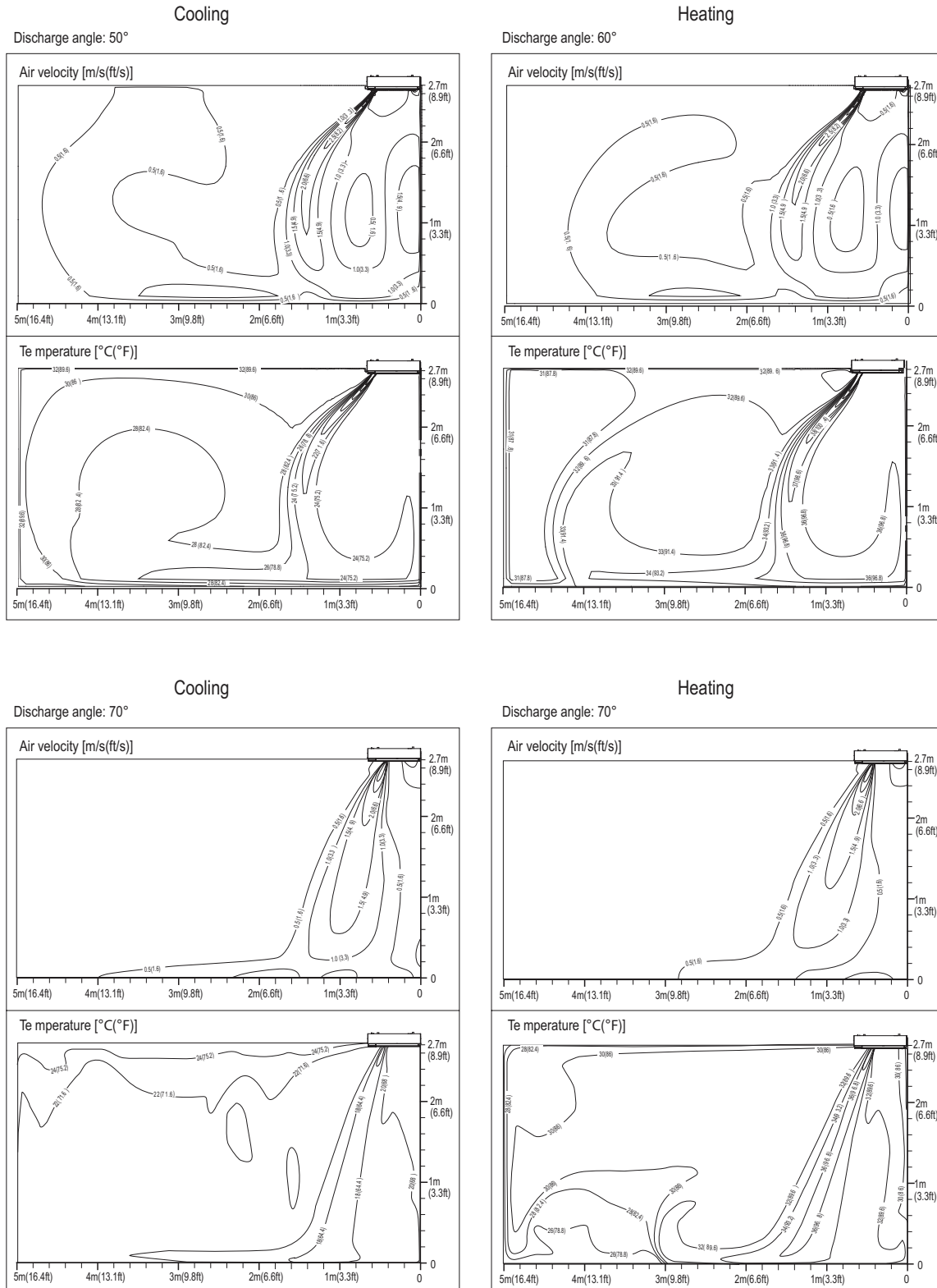

Figure 18: ARNU183TTD4.



The standard setup height is 8.9 ft. The charts above show the measurement distribution at the ceiling height of 8.9 ft with a high fan operating mode.

Figure 19: ARNU183TTD4, continued.



The standard setup height is 8.9 ft. The charts above show the measurement distribution at the ceiling height of 8.9 ft with a high fan operating mode.

# ONE-WAY CEILING CASSETTE



## Air Velocity / Temperature Distribution ARNU243TTD4

Figure 20: ARNU243TTD4.

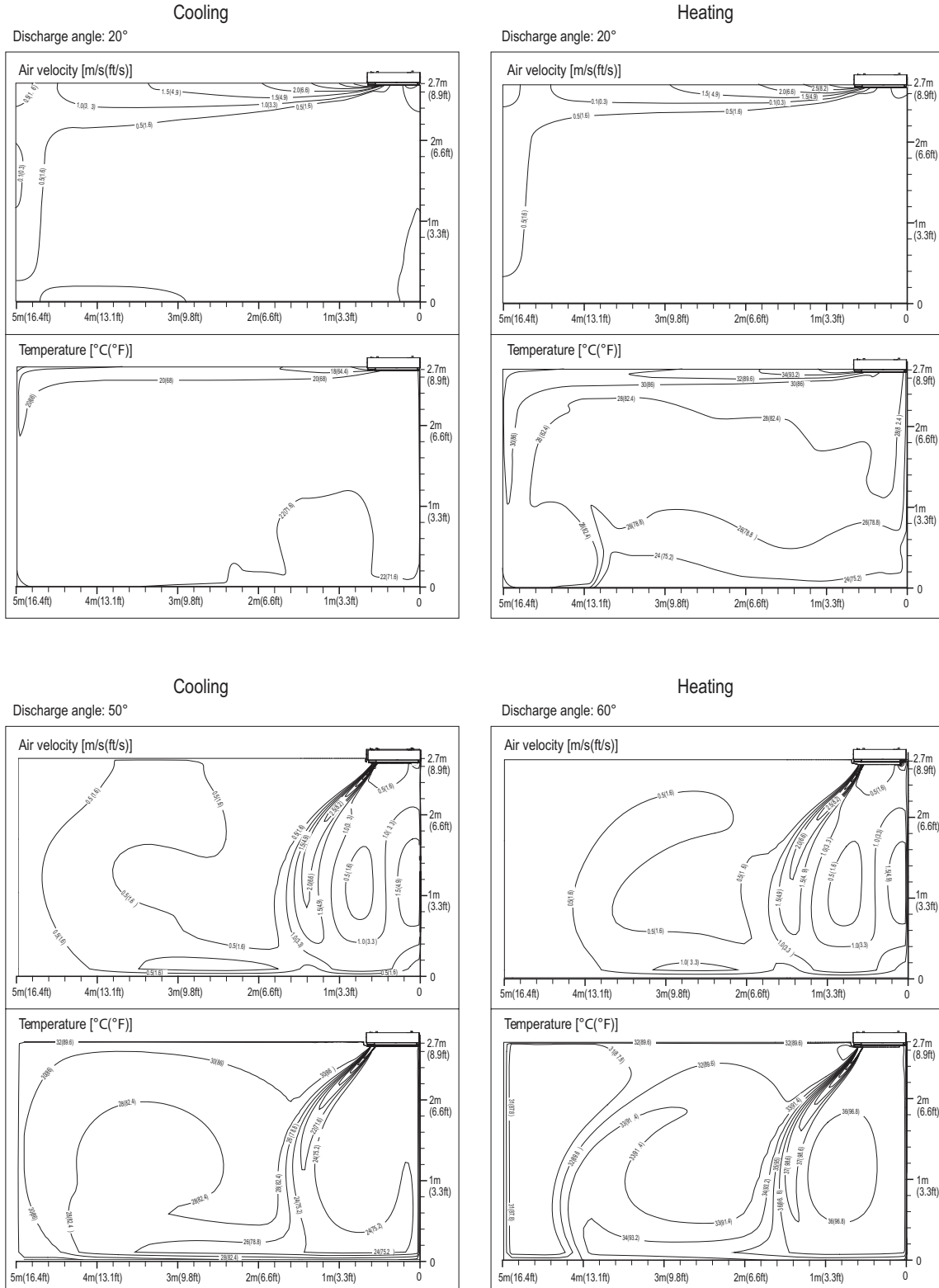

The standard setup height is 8.9 ft. The charts above show the measurement distribution at the ceiling height of 8.9 ft with a high fan operating mode.



Figure 21: ARNU243TTD4, continued.

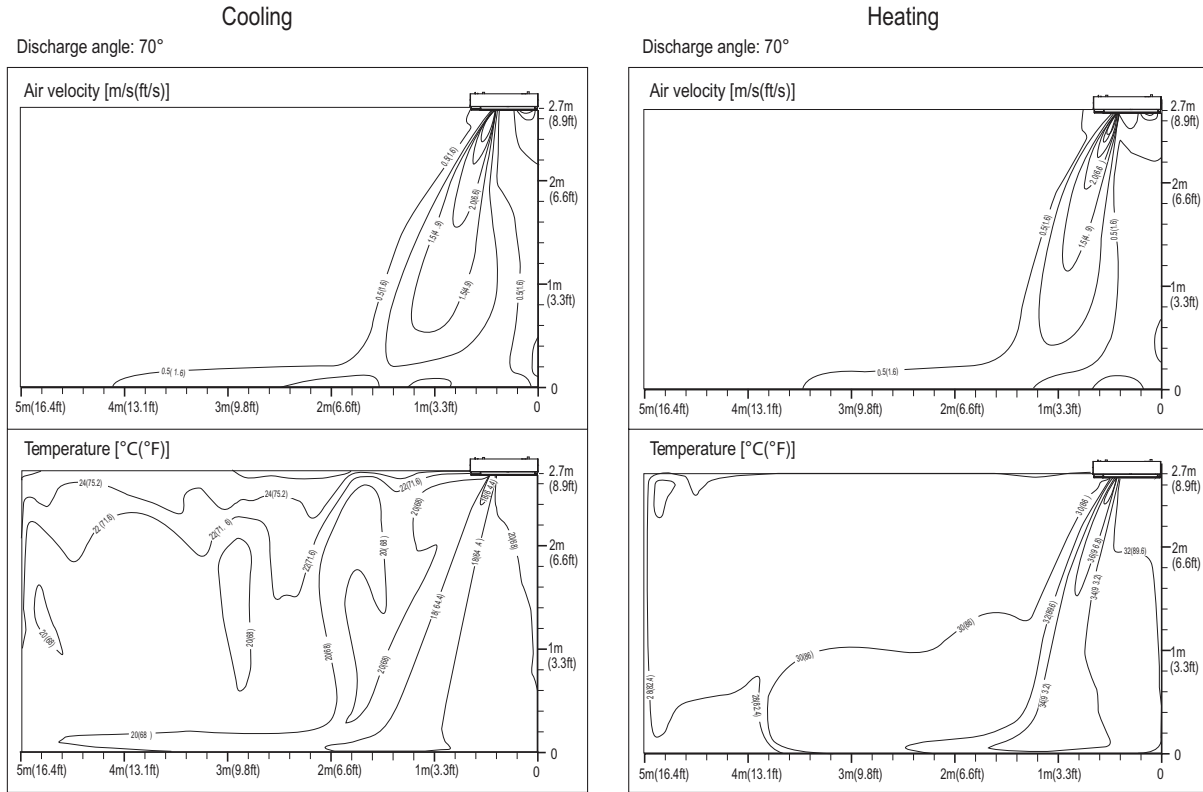

# ONE-WAY CEILING CASSETTE

Fresh Air Ventilation

TU, TT Frame

Figure 22: TU Frame Fresh Air Ventilation.

Fresh Air Ventilation (Open Knock-out on Cabinet Side)

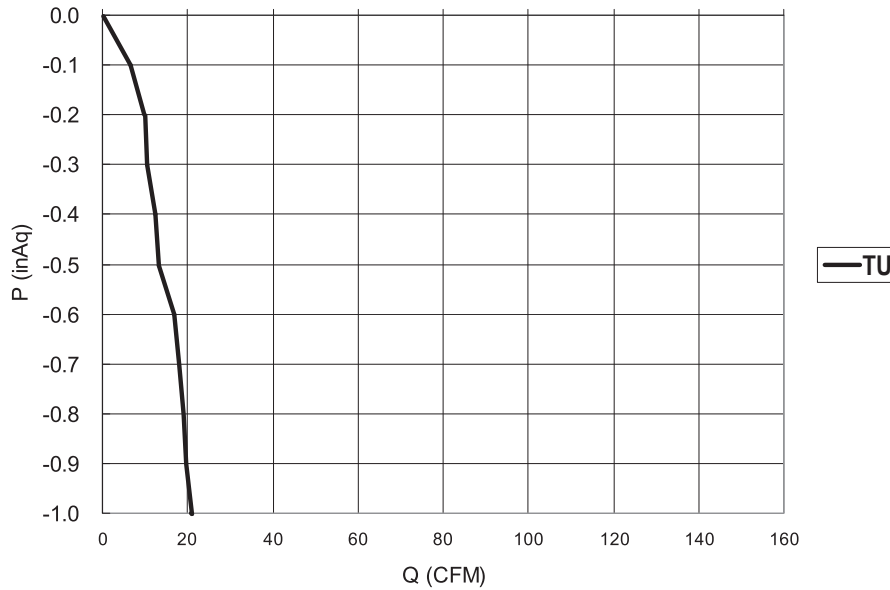

Figure 23: TT Frame Fresh Air Ventilation.

Fresh Air Ventilation (Open Knock-out on Cabinet Side)

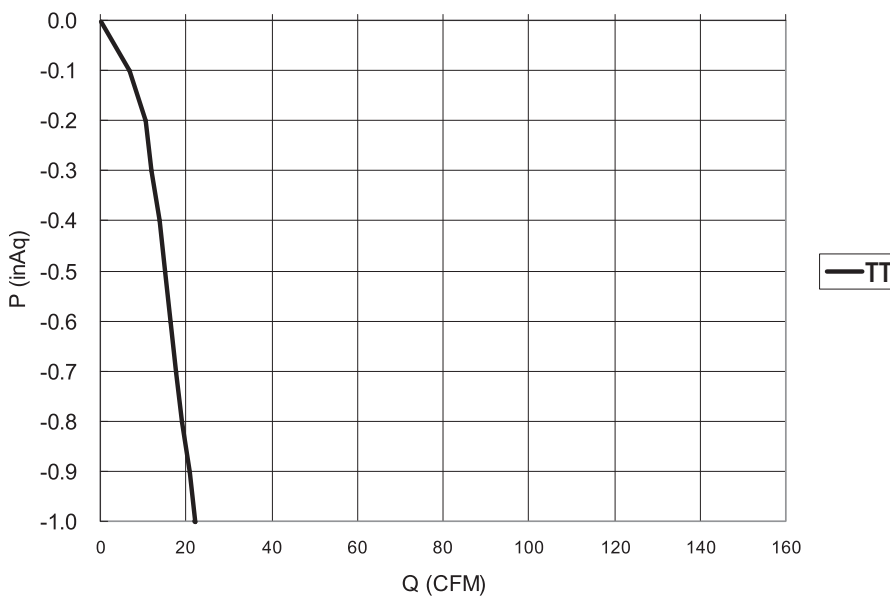

Table 10: ARNU073TUD4, ARNU093TUD4, ARNU123TUD4 Cooling Capacity Table.

Model No. / Capacity Index	Outdoor Air Temp. (°F DB)	Indoor Air Temperature (°F DB / WB)													
		68 / 57		73 / 61		79 / 64		80 / 67		85 / 70		88 / 73		91 / 76	
		TC MBh	SHC MBh	TC MBh	SHC MBh	TC MBh	SHC MBh	TC MBh	SHC MBh	TC MBh	SHC MBh	TC MBh	SHC MBh	TC MBh	SHC MBh
ARNU073TUD4 / 7.5	-9.9	4.9	4.2	6.0	4.8	6.8	5.2	7.5	5.5	8.4	5.9	8.9	5.8	9.7	5.8
	-5	4.9	4.2	6.0	4.8	6.8	5.2	7.5	5.5	8.4	5.9	8.9	5.8	9.7	5.8
	0	4.9	4.2	6.0	4.8	6.8	5.2	7.5	5.5	8.4	5.9	8.9	5.8	9.7	5.8
	5	4.9	4.2	6.0	4.8	6.8	5.2	7.5	5.5	8.4	5.9	8.9	5.8	9.7	5.8
	10	4.9	4.2	6.0	4.8	6.8	5.2	7.5	5.5	8.4	5.9	8.9	5.8	9.7	5.8
	14	4.9	4.2	6.0	4.8	6.8	5.2	7.5	5.5	8.4	5.9	8.9	5.8	9.7	5.8
	20	4.9	4.2	6.0	4.8	6.8	5.2	7.5	5.5	8.4	5.9	8.9	5.8	9.7	5.8
	23	4.9	4.2	6.0	4.8	6.8	5.2	7.5	5.5	8.4	5.9	8.9	5.8	9.7	5.8
	25	4.9	4.2	6.0	4.8	6.8	5.2	7.5	5.5	8.4	5.9	8.9	5.8	9.7	5.8
	30	4.9	4.2	6.0	4.8	6.8	5.2	7.5	5.5	8.4	5.9	8.9	5.8	9.7	5.8
	35	4.9	4.2	6.0	4.8	6.8	5.2	7.5	5.5	8.4	5.9	8.9	5.8	9.7	5.8
	40	4.9	4.2	6.0	4.8	6.8	5.2	7.5	5.5	8.4	5.9	8.9	5.8	9.7	5.8
	45	4.9	4.2	6.0	4.8	6.8	5.2	7.5	5.5	8.4	5.9	8.9	5.8	9.7	5.8
	50	4.9	4.2	6.0	4.8	6.8	5.2	7.5	5.5	8.4	5.9	8.9	5.8	9.7	5.8
	55	4.9	4.2	6.0	4.8	6.8	5.2	7.5	5.5	8.4	5.9	8.9	5.8	9.7	5.8
	60	4.9	4.2	6.0	4.8	6.8	5.2	7.5	5.5	8.4	5.9	8.9	5.8	9.6	5.8
	65	4.9	4.2	6.0	4.8	6.8	5.2	7.5	5.5	8.4	5.9	8.9	5.8	9.4	5.7
	70	4.9	4.2	6.0	4.8	6.8	5.2	7.5	5.5	8.4	5.9	8.9	5.8	9.3	5.6
	75	4.9	4.2	6.0	4.8	6.8	5.2	7.5	5.5	8.4	5.9	8.9	5.8	9.1	5.5
	80	4.9	4.2	6.0	4.8	6.8	5.2	7.5	5.5	8.4	5.9	8.7	5.8	8.8	5.5
85	4.9	4.2	6.0	4.8	6.8	5.2	7.5	5.5	8.3	5.8	8.4	5.6	8.6	5.3	
90	4.9	4.2	6.0	4.8	6.8	5.2	7.5	5.5	8.2	5.7	8.3	5.5	8.4	5.2	
95	4.9	4.2	6.0	4.8	6.8	5.2	<b>7.5</b>	<b>5.5</b>	8.0	5.7	8.2	5.4	8.3	5.1	
100	4.9	4.2	6.0	4.8	6.8	5.2	7.5	5.5	7.9	5.6	8.0	5.4	8.2	5.1	
105	4.9	4.2	5.7	4.6	6.4	4.9	7.2	5.3	7.5	5.3	7.7	5.2	7.9	5.0	
110	4.8	4.1	5.4	4.4	6.0	4.6	6.8	4.9	7.1	4.9	7.3	4.9	7.7	4.8	
115	4.7	4.0	5.1	4.1	5.6	4.3	6.3	4.7	6.6	4.7	7.0	4.7	7.4	4.6	
118	4.6	3.8	4.9	3.9	5.4	4.1	6.1	4.5	6.3	4.5	6.7	4.5	7.1	4.4	
122	4.5	3.7	4.6	3.7	5.1	3.8	5.8	4.2	6.0	4.2	6.3	4.2	6.8	4.2	
ARNU093TUD4 / 9.6	-9.9	6.3	5.3	7.7	6.1	8.6	6.5	9.6	6.9	10.8	7.4	11.4	7.3	12.4	7.3
	-5	6.3	5.3	7.7	6.1	8.6	6.5	9.6	6.9	10.8	7.4	11.4	7.3	12.4	7.3
	0	6.3	5.3	7.7	6.1	8.6	6.5	9.6	6.9	10.8	7.4	11.4	7.3	12.4	7.3
	5	6.3	5.3	7.7	6.1	8.6	6.5	9.6	6.9	10.8	7.4	11.4	7.3	12.4	7.3
	10	6.3	5.3	7.7	6.1	8.6	6.5	9.6	6.9	10.8	7.4	11.4	7.3	12.4	7.3
	14	6.3	5.3	7.7	6.1	8.6	6.5	9.6	6.9	10.8	7.4	11.4	7.3	12.4	7.3
	20	6.3	5.3	7.7	6.1	8.6	6.5	9.6	6.9	10.8	7.4	11.4	7.3	12.4	7.3
	23	6.3	5.3	7.7	6.1	8.6	6.5	9.6	6.9	10.8	7.4	11.4	7.3	12.4	7.3
	25	6.3	5.3	7.7	6.1	8.6	6.5	9.6	6.9	10.8	7.4	11.4	7.3	12.4	7.3
	30	6.3	5.3	7.7	6.1	8.6	6.5	9.6	6.9	10.8	7.4	11.4	7.3	12.4	7.3
	35	6.3	5.3	7.7	6.1	8.6	6.5	9.6	6.9	10.8	7.4	11.4	7.3	12.4	7.3
	40	6.3	5.3	7.7	6.1	8.6	6.5	9.6	6.9	10.8	7.4	11.4	7.3	12.4	7.3
	45	6.3	5.3	7.7	6.1	8.6	6.5	9.6	6.9	10.8	7.4	11.4	7.3	12.4	7.3
	50	6.3	5.3	7.7	6.1	8.6	6.5	9.6	6.9	10.8	7.4	11.4	7.3	12.4	7.3
	55	6.3	5.3	7.7	6.1	8.6	6.5	9.6	6.9	10.8	7.4	11.4	7.3	12.4	7.3
	60	6.3	5.3	7.7	6.1	8.6	6.5	9.6	6.9	10.8	7.4	11.4	7.3	12.3	7.3
	65	6.3	5.3	7.7	6.1	8.6	6.5	9.6	6.9	10.8	7.4	11.4	7.3	12.1	7.2
	70	6.3	5.3	7.7	6.1	8.6	6.5	9.6	6.9	10.8	7.4	11.4	7.3	11.9	7.1
	75	6.3	5.3	7.7	6.1	8.6	6.5	9.6	6.9	10.8	7.4	11.4	7.3	11.6	6.9
	80	6.3	5.3	7.7	6.1	8.6	6.5	9.6	6.9	10.8	7.4	11.1	7.3	11.3	6.9
85	6.3	5.3	7.7	6.1	8.6	6.5	9.6	6.9	10.6	7.3	10.8	7.0	11.0	6.6	
90	6.3	5.3	7.7	6.1	8.6	6.5	9.6	6.9	10.5	7.2	10.6	6.9	10.8	6.5	
95	6.3	5.3	7.7	6.1	8.6	6.5	<b>9.6</b>	<b>6.9</b>	10.3	7.2	10.5	6.8	10.6	6.4	
100	6.3	5.3	7.7	6.1	8.6	6.5	9.6	6.9	10.1	7.1	10.3	6.7	10.5	6.4	
105	6.3	5.3	7.3	5.8	8.2	6.2	9.2	6.6	9.6	6.6	9.9	6.5	10.2	6.2	
110	6.2	5.1	6.9	5.5	7.7	5.8	8.6	6.2	9.0	6.2	9.4	6.2	9.8	6.0	
115	6.0	5.0	6.6	5.2	7.2	5.4	8.1	5.9	8.5	5.9	8.9	5.9	9.4	5.8	
118	5.9	4.8	6.2	4.9	6.9	5.1	7.8	5.6	8.1	5.6	8.5	5.6	9.0	5.6	
122	5.7	4.7	5.9	4.7	6.5	4.8	7.4	5.3	7.7	5.3	8.1	5.3	8.7	5.3	

TC: Total Capacity (MBh); SHC: Sensible Heat Capacity (MBh).

The System Combination Ratio must be between 50–130%.

Rated capacity is certified under AHRI Standard 1230. Ratings are subject to change without notice.

Current certified ratings are available at [www.ahridirectory.org](http://www.ahridirectory.org).

For outdoor unit performance data, see the respective outdoor unit performance data manuals on [www.lghvac.com](http://www.lghvac.com).

Low ambient performance with LGRED® heat technology is included in Multi V 5 air source units produced after February 2019.



Due to our policy of continuous product innovation, some specifications may change without notification.

© LG Electronics U.S.A., Inc., Englewood Cliffs, NJ. All rights reserved. "LG" is a registered trademark of LG Corp.

# ONE-WAY CEILING CASSETTE



## Cooling Capacity Tables

### ARNU123TUD4

Table 11: ARNU123TUD4 Cooling Capacity Table.

Model No. / Capacity Index	Outdoor Air Temp. (°F DB)	Indoor Air Temperature (°F DB / WB)													
		68 / 57		73 / 61		79 / 64		80 / 67		85 / 70		88 / 73		91 / 76	
		TC MBh	SHC MBh	TC MBh	SHC MBh	TC MBh	SHC MBh	TC MBh	SHC MBh	TC MBh	SHC MBh	TC MBh	SHC MBh	TC MBh	SHC MBh
ARNU123TUD4 / 12.3	-9.9	8.1	6.8	9.8	7.9	11.1	8.4	12.3	8.9	13.8	9.6	14.7	9.5	15.9	9.5
	-5	8.1	6.8	9.8	7.9	11.1	8.4	12.3	8.9	13.8	9.6	14.7	9.5	15.9	9.5
	0	8.1	6.8	9.8	7.9	11.1	8.4	12.3	8.9	13.8	9.6	14.7	9.5	15.9	9.5
	5	8.1	6.8	9.8	7.9	11.1	8.4	12.3	8.9	13.8	9.6	14.7	9.5	15.9	9.5
	10	8.1	6.8	9.8	7.9	11.1	8.4	12.3	8.9	13.8	9.6	14.7	9.5	15.9	9.5
	14	8.1	6.8	9.8	7.9	11.1	8.4	12.3	8.9	13.8	9.6	14.7	9.5	15.9	9.5
	20	8.1	6.8	9.8	7.9	11.1	8.4	12.3	8.9	13.8	9.6	14.7	9.5	15.9	9.5
	23	8.1	6.8	9.8	7.9	11.1	8.4	12.3	8.9	13.8	9.6	14.7	9.5	15.9	9.5
	25	8.1	6.8	9.8	7.9	11.1	8.4	12.3	8.9	13.8	9.6	14.7	9.5	15.9	9.5
	30	8.1	6.8	9.8	7.9	11.1	8.4	12.3	8.9	13.8	9.6	14.7	9.5	15.9	9.5
	35	8.1	6.8	9.8	7.9	11.1	8.4	12.3	8.9	13.8	9.6	14.7	9.5	15.9	9.5
	40	8.1	6.8	9.8	7.9	11.1	8.4	12.3	8.9	13.8	9.6	14.7	9.5	15.9	9.5
	45	8.1	6.8	9.8	7.9	11.1	8.4	12.3	8.9	13.8	9.6	14.7	9.5	15.9	9.5
	50	8.1	6.8	9.8	7.9	11.1	8.4	12.3	8.9	13.8	9.6	14.7	9.5	15.9	9.5
	55	8.1	6.8	9.8	7.9	11.1	8.4	12.3	8.9	13.8	9.6	14.7	9.5	15.9	9.5
	60	8.1	6.8	9.8	7.9	11.1	8.4	12.3	8.9	13.8	9.6	14.7	9.5	15.7	9.4
	65	8.1	6.8	9.8	7.9	11.1	8.4	12.3	8.9	13.8	9.6	14.7	9.5	15.5	9.3
	70	8.1	6.8	9.8	7.9	11.1	8.4	12.3	8.9	13.8	9.6	14.7	9.5	15.3	9.1
	75	8.1	6.8	9.8	7.9	11.1	8.4	12.3	8.9	13.8	9.6	14.7	9.5	14.9	8.9
	80	8.1	6.8	9.8	7.9	11.1	8.4	12.3	8.9	13.8	9.6	14.2	9.4	14.5	8.9
85	8.1	6.8	9.8	7.9	11.1	8.4	12.3	8.9	13.6	9.5	13.8	9.0	14.0	8.5	
90	8.1	6.8	9.8	7.9	11.1	8.4	12.3	8.9	13.4	9.3	13.5	8.9	13.8	8.4	
95	8.1	6.8	9.8	7.9	11.1	8.4	<b>12.3</b>	<b>8.9</b>	13.2	9.3	13.4	8.8	13.6	8.3	
100	8.1	6.8	9.8	7.9	11.1	8.4	12.3	8.9	12.9	9.1	13.2	8.7	13.4	8.3	
105	8.1	6.8	9.3	7.5	10.6	8.0	11.8	8.5	12.3	8.5	12.7	8.4	13.0	8.1	
110	7.9	6.6	8.9	7.1	9.8	7.5	11.1	8.0	11.6	8.0	12.0	8.0	12.6	7.8	
115	7.7	6.4	8.4	6.7	9.2	7.0	10.4	7.6	10.9	7.6	11.4	7.6	12.1	7.5	
118	7.5	6.2	8.0	6.4	8.8	6.6	10.0	7.2	10.4	7.2	10.9	7.2	11.6	7.2	
122	7.3	6.0	7.6	6.0	8.3	6.2	9.4	6.9	9.8	6.9	10.3	6.9	11.1	6.9	

TC: Total Capacity (MBh); SHC: Sensible Heat Capacity (MBh).  
 The System Combination Ratio must be between 50–130%.  
 Rated capacity is certified under AHRI Standard 1230. Ratings are subject to change without notice.  
 Current certified ratings are available at [www.ahridirectory.org](http://www.ahridirectory.org).

For outdoor unit performance data, see the respective outdoor unit performance data manuals on [www.lghvac.com](http://www.lghvac.com).  
 Low ambient performance with LGRED® heat technology is included in Multi V 5 air source units produced after February 2019.



Table 12: ARNU183TTD4, ARNU243TTD4 Cooling Capacity Table.

Model No. / Capacity Index	Outdoor Air Temp. (°F DB)	Indoor Air Temperature (°F DB / WB)													
		68 / 57		73 / 61		79 / 64		80 / 67		85 / 70		88 / 73		91 / 76	
		TC MBh	SHC MBh	TC MBh	SHC MBh	TC MBh	SHC MBh	TC MBh	SHC MBh	TC MBh	SHC MBh	TC MBh	SHC MBh	TC MBh	SHC MBh
ARNU183TTD4 / 19.1	-9.9	12.6	10.2	15.3	11.7	17.2	12.5	19.1	13.3	21.4	14.3	22.8	14.1	24.7	14.1
	-5	12.6	10.2	15.3	11.7	17.2	12.5	19.1	13.3	21.4	14.3	22.8	14.1	24.7	14.1
	0	12.6	10.2	15.3	11.7	17.2	12.5	19.1	13.3	21.4	14.3	22.8	14.1	24.7	14.1
	5	12.6	10.2	15.3	11.7	17.2	12.5	19.1	13.3	21.4	14.3	22.8	14.1	24.7	14.1
	10	12.6	10.2	15.3	11.7	17.2	12.5	19.1	13.3	21.4	14.3	22.8	14.1	24.7	14.1
	14	12.6	10.2	15.3	11.7	17.2	12.5	19.1	13.3	21.4	14.3	22.8	14.1	24.7	14.1
	20	12.6	10.2	15.3	11.7	17.2	12.5	19.1	13.3	21.4	14.3	22.8	14.1	24.7	14.1
	23	12.6	10.2	15.3	11.7	17.2	12.5	19.1	13.3	21.4	14.3	22.8	14.1	24.7	14.1
	25	12.6	10.2	15.3	11.7	17.2	12.5	19.1	13.3	21.4	14.3	22.8	14.1	24.7	14.1
	30	12.6	10.2	15.3	11.7	17.2	12.5	19.1	13.3	21.4	14.3	22.8	14.1	24.7	14.1
	35	12.6	10.2	15.3	11.7	17.2	12.5	19.1	13.3	21.4	14.3	22.8	14.1	24.7	14.1
	40	12.6	10.2	15.3	11.7	17.2	12.5	19.1	13.3	21.4	14.3	22.8	14.1	24.7	14.1
	45	12.6	10.2	15.3	11.7	17.2	12.5	19.1	13.3	21.4	14.3	22.8	14.1	24.7	14.1
	50	12.6	10.2	15.3	11.7	17.2	12.5	19.1	13.3	21.4	14.3	22.8	14.1	24.7	14.1
	55	12.6	10.2	15.3	11.7	17.2	12.5	19.1	13.3	21.4	14.3	22.8	14.1	24.7	14.1
	60	12.6	10.2	15.3	11.7	17.2	12.5	19.1	13.3	21.4	14.3	22.8	14.1	24.4	14.0
	65	12.6	10.2	15.3	11.7	17.2	12.5	19.1	13.3	21.4	14.3	22.8	14.1	24.0	13.8
	70	12.6	10.2	15.3	11.7	17.2	12.5	19.1	13.3	21.4	14.3	22.8	14.1	23.7	13.6
	75	12.6	10.2	15.3	11.7	17.2	12.5	19.1	13.3	21.4	14.3	22.8	14.1	23.1	13.3
	80	12.6	10.2	15.3	11.7	17.2	12.5	19.1	13.3	21.4	14.3	22.1	14.0	22.5	13.2
	85	12.6	10.2	15.3	11.7	17.2	12.5	19.1	13.3	21.2	14.1	21.4	13.4	21.8	12.7
90	12.6	10.2	15.3	11.7	17.2	12.5	19.1	13.3	20.9	13.9	21.0	13.2	21.4	12.5	
95	12.6	10.2	15.3	11.7	17.2	12.5	<b>19.1</b>	<b>13.3</b>	20.5	13.8	20.9	13.1	21.2	12.4	
100	12.6	10.2	15.3	11.7	17.2	12.5	19.1	13.3	20.1	13.6	20.5	13.0	20.9	12.3	
105	12.6	10.2	14.5	11.1	16.4	11.9	18.3	12.7	19.0	12.7	19.7	12.5	20.2	12.0	
110	12.3	9.9	13.8	10.5	15.3	11.1	17.2	11.9	18.0	11.9	18.7	11.9	19.5	11.7	
115	12.0	9.6	13.1	10.0	14.4	10.5	16.2	11.4	16.9	11.4	17.8	11.4	18.7	11.2	
118	11.7	9.3	12.4	9.5	13.6	9.8	15.5	10.8	16.1	10.8	17.0	10.8	18.0	10.7	
122	11.3	9.0	11.8	9.0	12.9	9.3	14.7	10.2	15.3	10.2	16.0	10.2	17.2	10.2	
ARNU243TTD4 / 24.2	-9.9	15.9	13.0	19.4	15.0	21.8	15.9	24.2	17.0	27.1	18.2	28.8	18.0	31.3	18.0
	-5	15.9	13.0	19.4	15.0	21.8	15.9	24.2	17.0	27.1	18.2	28.8	18.0	31.3	18.0
	0	15.9	13.0	19.4	15.0	21.8	15.9	24.2	17.0	27.1	18.2	28.8	18.0	31.3	18.0
	5	15.9	13.0	19.4	15.0	21.8	15.9	24.2	17.0	27.1	18.2	28.8	18.0	31.3	18.0
	10	15.9	13.0	19.4	15.0	21.8	15.9	24.2	17.0	27.1	18.2	28.8	18.0	31.3	18.0
	14	15.9	13.0	19.4	15.0	21.8	15.9	24.2	17.0	27.1	18.2	28.8	18.0	31.3	18.0
	20	15.9	13.0	19.4	15.0	21.8	15.9	24.2	17.0	27.1	18.2	28.8	18.0	31.3	18.0
	23	15.9	13.0	19.4	15.0	21.8	15.9	24.2	17.0	27.1	18.2	28.8	18.0	31.3	18.0
	25	15.9	13.0	19.4	15.0	21.8	15.9	24.2	17.0	27.1	18.2	28.8	18.0	31.3	18.0
	30	15.9	13.0	19.4	15.0	21.8	15.9	24.2	17.0	27.1	18.2	28.8	18.0	31.3	18.0
	35	15.9	13.0	19.4	15.0	21.8	15.9	24.2	17.0	27.1	18.2	28.8	18.0	31.3	18.0
	40	15.9	13.0	19.4	15.0	21.8	15.9	24.2	17.0	27.1	18.2	28.8	18.0	31.3	18.0
	45	15.9	13.0	19.4	15.0	21.8	15.9	24.2	17.0	27.1	18.2	28.8	18.0	31.3	18.0
	50	15.9	13.0	19.4	15.0	21.8	15.9	24.2	17.0	27.1	18.2	28.8	18.0	31.3	18.0
	55	15.9	13.0	19.4	15.0	21.8	15.9	24.2	17.0	27.1	18.2	28.8	18.0	31.3	18.0
	60	15.9	13.0	19.4	15.0	21.8	15.9	24.2	17.0	27.1	18.2	28.8	18.0	31.0	17.9
	65	15.9	13.0	19.4	15.0	21.8	15.9	24.2	17.0	27.1	18.2	28.8	18.0	30.5	17.7
	70	15.9	13.0	19.4	15.0	21.8	15.9	24.2	17.0	27.1	18.2	28.8	18.0	30.0	17.4
	75	15.9	13.0	19.4	15.0	21.8	15.9	24.2	17.0	27.1	18.2	28.8	18.0	29.2	17.0
	80	15.9	13.0	19.4	15.0	21.8	15.9	24.2	17.0	27.1	18.2	28.0	17.9	28.5	16.9
	85	15.9	13.0	19.4	15.0	21.8	15.9	24.2	17.0	26.8	18.0	27.1	17.2	27.6	16.2
90	15.9	13.0	19.4	15.0	21.8	15.9	24.2	17.0	26.4	17.8	26.6	16.9	27.1	16.0	
95	15.9	13.0	19.4	15.0	21.8	15.9	<b>24.2</b>	<b>17.0</b>	25.9	17.7	26.4	16.8	26.8	15.8	
100	15.9	13.0	19.4	15.0	21.8	15.9	24.2	17.0	25.4	17.4	25.9	16.6	26.4	15.7	
105	15.9	13.0	18.4	14.2	20.8	15.3	23.2	16.2	24.1	16.2	24.9	16.0	25.6	15.4	
110	15.5	12.6	17.4	13.5	19.4	14.2	21.8	15.3	22.8	15.3	23.7	15.3	24.7	14.9	
115	15.1	12.2	16.6	12.8	18.2	13.4	20.5	14.5	21.4	14.5	22.5	14.5	23.7	14.3	
118	14.8	11.9	15.7	12.1	17.3	12.6	19.7	13.8	20.4	13.8	21.5	13.8	22.8	13.7	
122	14.4	11.5	15.0	11.5	16.3	11.8	18.6	13.1	19.4	13.1	20.3	13.1	21.9	13.1	

TC: Total Capacity (MBh); SHC: Sensible Heat Capacity (MBh).

The System Combination Ratio must be between 50–130%.

Rated capacity is certified under AHRI Standard 1230. Ratings are subject to change without notice. Current certified ratings are available at [www.ahrirectory.org](http://www.ahrirectory.org).

For outdoor unit performance data, see the respective outdoor unit performance data manuals on [www.lghvac.com](http://www.lghvac.com).

Low ambient performance with LGRED® heat technology is included in Multi V 5 air source units produced after February 2019.



# ONE-WAY CEILING CASSETTE



## Heating Capacity Tables

### ARNU073TUD4, ARNU093TUD4, ARNU123TUD4

Table 13: ARNU073TUD4, ARNU093TUD4, ARNU123TUD4 Heating Capacity Table.

Model No. / Capacity Index	Outdoor Air Temp.		Indoor Air Temperature (°F DB)							
			59	61	64	67	70	73	76	80
	°F DB	°F WB	TC	TC	TC	TC	TC	TC	TC	TC
		MBh	MBh	MBh	MBh	MBh	MBh	MBh	MBh	MBh
ARNU073TUD4 / 7.5	-21.6	-22.0	4.3	4.3	4.3	4.3	4.3	4.3	4.3	4.3
	-17.1	-17.5	4.8	4.8	4.8	4.8	4.8	4.8	4.8	4.8
	-12.6	-13	5.4	5.4	5.4	5.4	5.3	5.3	5.3	5.3
	-7	-7.6	5.5	5.5	5.5	5.5	5.4	5.4	5.4	5.4
	-4	-4.4	5.7	5.7	5.7	5.7	5.6	5.6	5.6	5.6
	0	-0.4	5.9	5.9	5.9	5.9	5.9	5.8	5.8	5.8
	5	4.5	6.6	6.6	6.5	6.5	6.5	6.5	6.5	6.5
	10	9	6.9	6.9	6.9	6.8	6.8	6.8	6.8	6.8
	15	14	7.3	7.3	7.3	7.3	7.3	7.3	7.2	7.1
	20	19	7.7	7.7	7.7	7.7	7.6	7.6	7.4	7.4
	25	23	8.1	8.1	8.1	8.1	8.1	7.9	7.8	7.4
	30	28	8.3	8.3	8.3	8.3	8.3	8.1	7.8	7.4
	35	32	8.5	8.5	8.5	8.5	8.4	8.3	7.8	7.4
	40	36	8.8	8.8	8.8	8.8	8.5	8.3	7.8	7.4
	45	41	9.2	9.2	9.2	8.9	8.5	8.3	7.8	7.4
47	43	9.5	9.4	9.4	8.9	<b>8.5</b>	8.3	7.8	7.4	
50	46	10.2	9.8	9.4	8.9	8.5	8.3	7.8	7.4	
55	51	10.4	9.9	9.4	8.9	8.5	8.3	7.8	7.4	
60	56	10.4	9.9	9.4	8.9	8.5	8.3	7.8	7.4	
ARNU093TUD4 / 9.6	-21.6	-22.0	5.5	5.5	5.5	5.5	5.5	5.5	5.5	5.5
	-17.1	-17.5	6.2	6.2	6.2	6.2	6.1	6.1	6.1	6.1
	-12.6	-13	6.9	6.9	6.9	6.9	6.8	6.8	6.8	6.8
	-7	-7.6	7.1	7.1	7.1	7.1	7.0	7.0	7.0	7.0
	-4	-4.4	7.3	7.3	7.3	7.3	7.2	7.2	7.2	7.2
	0	-0.4	7.5	7.5	7.5	7.5	7.5	7.4	7.4	7.4
	5	4.5	8.5	8.4	8.3	8.3	8.3	8.3	8.3	8.3
	10	9	8.8	8.8	8.8	8.7	8.7	8.7	8.7	8.7
	15	14	9.4	9.4	9.4	9.4	9.4	9.4	9.3	9.2
	20	19	9.9	9.9	9.9	9.9	9.7	9.7	9.5	9.4
	25	23	10.4	10.4	10.4	10.4	10.4	10.1	10.0	9.5
	30	28	10.6	10.6	10.6	10.6	10.6	10.4	10.0	9.5
	35	32	10.9	10.9	10.9	10.9	10.8	10.6	10.0	9.5
	40	36	11.3	11.3	11.3	11.3	10.9	10.6	10.0	9.5
	45	41	11.8	11.8	11.8	11.5	10.9	10.6	10.0	9.5
47	43	12.2	12.1	12.0	11.5	<b>10.9</b>	10.6	10.0	9.5	
50	46	13.1	12.5	12.0	11.5	10.9	10.6	10.0	9.5	
55	51	13.4	12.6	12.0	11.5	10.9	10.6	10.0	9.5	
60	56	13.4	12.6	12.0	11.5	10.9	10.6	10.0	9.5	
ARNU123TUD4 / 12.3	-21.6	-22.0	6.9	6.9	6.9	6.9	6.8	6.8	6.8	6.8
	-17.1	-17.5	7.7	7.7	7.7	7.7	7.6	7.6	7.6	7.6
	-12.6	-13	8.6	8.6	8.6	8.6	8.5	8.5	8.5	8.5
	-7	-7.6	8.8	8.8	8.8	8.8	8.7	8.7	8.7	8.7
	-4	-4.4	9.1	9.1	9.1	9.1	9.0	9.0	9.0	9.0
	0	-0.4	9.4	9.4	9.4	9.4	9.4	9.3	9.3	9.3
	5	4.5	10.6	10.5	10.3	10.3	10.3	10.3	10.3	10.3
	10	9	11.0	11.0	11.0	10.9	10.9	10.9	10.9	10.9
	15	14	11.7	11.7	11.7	11.7	11.7	11.7	11.6	11.4
	20	19	12.4	12.4	12.4	12.4	12.1	12.1	11.9	11.8
	25	23	12.9	12.9	12.9	12.9	12.9	12.7	12.5	11.9
	30	28	13.2	13.2	13.2	13.2	13.2	12.9	12.5	11.9
	35	32	13.6	13.6	13.6	13.6	13.5	13.2	12.5	11.9
	40	36	14.1	14.1	14.1	14.1	13.6	13.2	12.5	11.9
	45	41	14.7	14.7	14.7	14.3	13.6	13.2	12.5	11.9
47	43	15.2	15.1	15.0	14.3	<b>13.6</b>	13.2	12.5	11.9	
50	46	16.3	15.6	15.0	14.3	13.6	13.2	12.5	11.9	
55	51	16.7	15.8	15.0	14.3	13.6	13.2	12.5	11.9	
60.0	56.0	16.7	15.8	15.0	14.3	13.6	13.2	12.5	11.9	

TC: Total Capacity (MBh).

The System Combination Ratio must be between 50–130%.

Rated capacity is certified under AHRI Standard 1230. Ratings are subject to change without notice.

Current certified ratings are available at [www.ahridirectory.org](http://www.ahridirectory.org). Due to our policy of continuous product innovation, some specifications may change without notification.

For ODU performance data, see the respective ODU performance data manuals on [www.lghvac.com](http://www.lghvac.com).

Low ambient performance with LGRED® heat technology is included in Multi V 5 air source units produced after February 2019.



Table 14: ARNU183TTD4, ARNU243TTD4 Heating Capacity Table.

Model No. / Capacity Index	Outdoor Air Temp.		Indoor Air Temperature (°F DB)							
			59	61	64	67	70	73	76	80
	°F DB	°F WB	TC MBh	TC MBh	TC MBh	TC MBh	TC MBh	TC MBh	TC MBh	TC MBh
ARNU183TTD4 / 19.1	-21.6	-22.0	10.9	10.9	10.9	10.9	10.8	10.8	10.8	10.8
	-17.1	-17.5	12.2	12.2	12.2	12.2	12.1	12.1	12.1	12.1
	-12.6	-13	13.6	13.6	13.6	13.6	13.4	13.4	13.4	13.4
	-7	-7.6	14.0	14.0	14.0	14.0	13.8	13.8	13.8	13.8
	-4	-4.4	14.4	14.4	14.4	14.4	14.2	14.2	14.2	14.2
	0	-0.4	14.8	14.8	14.8	14.8	14.8	14.6	14.6	14.6
	5	4.5	16.8	16.6	16.3	16.3	16.3	16.3	16.3	16.3
	10	9	17.4	17.4	17.4	17.2	17.2	17.2	17.2	17.2
	15	14	18.5	18.5	18.5	18.5	18.5	18.5	18.3	18.1
	20	19	19.6	19.6	19.6	19.6	19.1	19.1	18.8	18.6
	25	23	20.4	20.4	20.4	20.4	20.4	20.0	19.8	18.8
	30	28	20.9	20.9	20.9	20.9	20.9	20.4	19.8	18.8
	35	32	21.5	21.5	21.5	21.5	21.3	20.9	19.8	18.8
	40	36	22.4	22.4	22.4	22.4	21.5	20.9	19.8	18.8
	45	41	23.2	23.2	23.2	22.6	21.5	20.9	19.8	18.8
47	43	24.1	23.9	23.7	22.6	<b>21.5</b>	20.9	19.8	18.8	
50	46	25.8	24.7	23.7	22.6	21.5	20.9	19.8	18.8	
55	51	26.3	24.9	23.7	22.6	21.5	20.9	19.8	18.8	
60	56	26.3	24.9	23.7	22.6	21.5	20.9	19.8	18.8	
ARNU243TTD4 / 24.2	-21.6	-22.0	12.3	12.3	12.3	12.3	12.1	12.1	12.1	12.1
	-17.1	-17.5	13.8	13.8	13.8	13.8	13.6	13.6	13.6	13.6
	-12.6	-13	15.3	15.3	15.3	15.3	15.0	15.0	15.0	15.0
	-7	-7.6	15.7	15.7	15.7	15.7	15.5	15.5	15.5	15.5
	-4	-4.4	16.2	16.2	16.2	16.2	16.0	16.0	16.0	16.0
	0	-0.4	16.7	16.7	16.7	16.7	16.7	16.5	16.5	16.5
	5	4.5	18.9	18.6	18.4	18.4	18.4	18.4	18.4	18.4
	10	9	19.6	19.6	19.6	19.4	19.4	19.4	19.4	19.4
	15	14	20.8	20.8	20.8	20.8	20.8	20.8	20.6	20.3
	20	19	22.0	22.0	22.0	22.0	21.5	21.5	21.2	20.9
	25	23	23.0	23.0	23.0	23.0	23.0	22.5	22.3	21.2
	30	28	23.5	23.5	23.5	23.5	23.5	23.0	22.3	21.2
	35	32	24.2	24.2	24.2	24.2	24.0	23.5	22.3	21.2
	40	36	25.2	25.2	25.2	25.2	24.2	23.5	22.3	21.2
	45	41	26.1	26.1	26.1	25.4	24.2	23.5	22.3	21.2
47	43	27.1	26.9	26.6	25.4	<b>24.2</b>	23.5	22.3	21.2	
50	46	29.0	27.8	26.6	25.4	24.2	23.5	22.3	21.2	
55	51	29.7	28.1	26.6	25.4	24.2	23.5	22.3	21.2	
60	56	29.7	28.1	26.6	25.4	24.2	23.5	22.3	21.2	

TC: Total Capacity (MBh).

The System Combination Ratio must be between 50–130%.

Rated capacity is certified under AHRI Standard 1230. Ratings are subject to change without notice. Current certified ratings are available at [www.ahridirectory.org](http://www.ahridirectory.org).

For outdoor unit performance data, see the respective outdoor unit performance data manuals on [www.lghvac.com](http://www.lghvac.com).

Low ambient performance with LGRED® heat technology is included in Multi V 5 air source units produced after February 2019.

# ONE-WAY CEILING CASSETTE



## Accessories

Table 15: Accessories for One-Way Ceiling-Cassette Indoor Units.

Accessory	Model Number
One-Way Ceiling Cassette Grille Kit (One Required) <sup>1</sup>	PT-UUC1 (For 7 to 12MBh One-Way Indoor Units) PT-UTC (For 18 and 24MBh One-Way Indoor Units)
Auxiliary Heater Kit <sup>1</sup>	PRARH1 (For Both TU and TT One-Way Indoor Units)
Wi-Fi Module <sup>1</sup>	PWFMDD200 (For Both TU and TT One-Way Indoor Units)

<sup>1</sup>For use with all one-way ceiling-cassette indoor units.  
All accessories are sold separately.



# TWO-WAY CEILING CASSETTE



**Mechanical Specifications on page 42**

**General Data on page 44**

**Electrical Data on page 44**

**External Dimensions on page 45**

**Electrical Wiring Diagram on page 46**

**Refrigerant Flow Diagram on page 48**

**Acoustic Data on page 49**

**Air Velocity / Temperature Distribution on page 51**

**Capacity Tables on page 55**

**Optional Accessories on page 57**

# TWO-WAY CEILING CASSETTE



## Mechanical Specifications

### Casing

The case is designed to mount recessed in the ceiling and has a surface-mounted concentric grille on the bottom of the unit. The unit case is manufactured with coated metal, and cold surfaces are covered with a coated polystyrene insulating material. The case is provided with metal ears designed to support the unit weight on four corners. Ears have pre-punched holes designed to accept field-supplied, all-thread rod hangers.

### Ventilation Air

The case has a factory designated cutout for the connection of a field supplied outside air duct.

### Architectural Filter/Grille

The ceiling cassette assembly is provided with an off-white ABS polymeric resin architectural grille with a tapered trim edge and a hinged, spring clip (screw-less) return air filter-grille door.

### Fan Assembly and Control

The indoor unit has a single, direct-drive, turbo fan. The fan wheel is made of high strength ABS HT-700 polymeric resin. The fan motor is a Brushless Digitally-Controlled (BLDC) design with permanently lubricated and sealed ball bearings. The fan motor includes thermal, overcurrent and low RPM protection. The fan / motor assembly is mounted on vibration attenuating rubber grommets. The fan impeller is statically and dynamically balanced. The fan speed is controlled using a microprocessor-based direct digital control algorithm that provides a high fan speed in cooling thermal ON and low fan speed in cooling thermal OFF, high fan speed in heating thermal ON and fan off in heating thermal OFF. The fan speeds can be field adjusted between low, medium, and high speeds. The fan speed algorithm provides a field selectable, fixed-speed or auto-speed setting that adjusts the fan speed to simulate natural airflow.

### Air Filter

Return air is filtered with a removable, washable filter with anti-fungal treatment.

### Airflow Guide Vanes

The architectural grille has two parallel directional slot diffusers each equipped with oscillating motorized guide vanes designed to change the angle airflow is discharged. Discharge range of motion is 40° in an up/down direction. The control algorithm provides the capability of locking guide vanes in a field adjusted fixed position.

### Microprocessor Controls

The unit is provided with an integrated microprocessor controller capable of performing functions necessary to operate the system without the use of a wall-mounted controller. A temperature thermistor is factory-mounted in the return air stream. All unit operation parameters, excluding the units operating schedule, are stored in non-volatile memory resident on the unit microprocessor. Operating schedules are stored in select models of the optional, wall-mounted, local, or central controller. The field-supplied communication cable between the indoor unit(s) and outdoor unit is to be a minimum of 18 AWG, 2 conductor, twisted, stranded, and shielded cable (RS 485), terminated via screw terminals on the control boards. The microprocessor control provides the following functions: auto addressing, self-diagnostics, auto restart following power restoration, test run, and will operate the indoor unit using one of five operating modes:



1. Auto Changeover (Heat Recovery only)
2. Heating
3. Cooling
4. Dry
5. Fan Only

For Heat Recovery systems the Auto Changeover setting automatically switches control of the indoor unit between Cooling and Heating modes based on space temperature conditions.

For Heat Pump systems, heated or cooled air delivery is dependent upon outdoor unit operating mode.

In Heating mode, the microprocessor control will activate indoor unit operation when the indoor room temperature falls below set-point temperature. At which point, a signal is sent to the outdoor unit to begin the heating cycle. The indoor unit fan operation is delayed until coil pipe temperature reaches 76°F. Significant airflow is generated when pipe temperature reaches 80°F. The unit is equipped with an infrared receiver designed to communicate with an LG wireless remote controller. In lieu of wireless remote or factory return air thermistor, screw terminals on the microprocessor circuit board accommodate various models of wall-mounted local controllers and or wall-mounted temperature sensors. The unit microprocessor is capable of accepting space temperature readings concurrently or individually from either:

1. Wall-mounted wired controller(s)
2. Factory mounted return air thermistor or the optional wall mounted wired remote temperature sensor.

A single indoor unit has the capability of being controlled by up to two local wired controllers. The microprocessor controls space temperature using the value provided by the temperature sensor sensing a space temperature that is farthest away from the temperature set-point. The microprocessor control provides a cooling or heating mode test cycle that operates the unit for 18 minutes without regard to space temperature. If the system is provided with an optional wall-mounted or central controller, displayed diagnostic codes are specific, alpha numeric, and provide the service technician with the reason for the code displayed.

Indoor units are Wi-Fi compatible with the addition of an LG Wi-Fi module accessory, and can be controlled by LG's Smart ThinQ™ app on a smart device. A field-supplied Wi-Fi network and smart device are required. The Smart ThinQ app is free, and is available for Android™ and iOS. (Android is a trademark of Google LLC.)

**Condensate Lift/Pump**

The indoor unit is provided with a factory installed and wired condensate lift/pump capable of providing a maximum 27-1/2 inch lift from the bottom surface of the unit. The lift pump comes with a safety switch that will shut off the indoor unit if condensate rises too high in the drain pan.

**Condensate Drain Pan**

The condensate drain pan is constructed of EPS (expandable polystyrene resin).

*\*To enable Generation 4 features, outdoor unit DIP Switch No. 3 must be set to ON. Please refer to the Multi V 5, Multi V IV, Multi V Water IV, Multi V S Engineering Manual for additional information.*

**Coil**

The indoor unit coil is constructed with grooved design copper tubes with slit coil fins, two (2) rows, twenty (20) fins per inch.

**Controls Features**

- Auto changeover (Heat Recovery only)
- Auto operation
- Auto restart
- External on/off control
- Dual thermistor control
- Dual set-point control
- Filter life display
- Multiple auxiliary heater applications
- Group control
- High ceiling
- Hot start
- Self diagnostics
- Timer (on / off)
- Weekly schedule
- Auto direction / swing (up /down)
- Fan speed control
- Jet cool (fast cooling)
- Auto fan
- Leak detection
- Wi-Fi compatible

# TWO-WAY CEILING CASSETTE



## General Data / Electrical Data

Table 16: Two-Way Ceiling Cassette (TS Frames) Indoor Unit General Data.

Model No.	ARNU183TSA4	ARNU243TSA4
<i>Cooling Mode Performance</i>		
Capacity (Btu/h)	19,100	24,200
Max Power Input <sup>1</sup> (W)	70	70
L/M/H Power Input at Factory Default (W)	24 / 29 / 34	25 / 30 / 40
<i>Heating Mode Performance</i>		
Capacity (Btu/h)	21,500	27,300
Max Power Input <sup>1</sup> (W)	70	70
L/M/H Power Input at Factory Default (W)	24 / 29 / 34	25 / 30 / 40
<i>Entering Mixed Air</i>		
Cooling Max (°F WB)	76	76
Heating Min (°F DB)	59	59
<i>Unit Data</i>		
Refrigerant Type <sup>2</sup>	R410A	R410A
Refrigerant Control	EEV	EEV
Sound Pressure <sup>3</sup> dB(A) (H/M/L)	35 / 33 / 31	40 / 37 / 33
Net Unit Weight (lbs.)	39.9	39.9
Shipping Weight (lbs.)	49.6	49.6
Grille Weight (lbs)	10.3	10.3
Grille Shipping Weight (lbs)	14.3	14.3
Communication Cable <sup>4</sup> (No. x AWG)	2 x 18	2 x 18
<i>Fan</i>		
Type	Turbo Fan	Turbo Fan
Quantity	1	1
Motor/Drive	Brushless Digitally Controlled / Direct	
Airflow Rate H/M/L (CFM)	417 / 381 / 348	512 / 438 / 364
<i>Piping</i>		
Liquid Line (in., O.D.)	1/4 Flare	3/8 Flare
Vapor Line (in., O.D.)	1/2 Flare	5/8 Flare
Condensate Line (in., I.D.)	1	1

EEV: Electronic Expansion Valve

Power wiring is field supplied and must comply with the applicable local and national codes. See below for detailed electrical data.

This unit comes with a dry nitrogen charge.

All capacities are net with a combination ratio between 95-105%.

Rated capacity is certified under AHRI Standard 1230. Ratings are subject to change without notice. Current certified ratings are available at [www.ahridirectory.org](http://www.ahridirectory.org).

Low ambient performance with LGRED<sup>®</sup> heat technology is included in Multi V 5 air source units produced after February 2019.

<sup>1</sup>Max power Input is rated at maximum setting value.

<sup>2</sup>Take appropriate actions at the end of HVAC equipment life to recover, recycle, reclaim or destroy R410A refrigerant according to applicable regulations (40 CFR Part 82, Subpart F) under section 608 of CAA.

<sup>3</sup>Sound Pressure levels are tested in an anechoic chamber under ISO Standard 3745.

<sup>4</sup>Communication cable between Master ODU to IDUs / HRUs to be 18 AWG, 2-conductor, twisted, stranded, shielded. Ensure the communication cable shield is properly grounded to the Master ODU chassis only. ⚠ Do not ground the ODU to IDUs / HRUs communication cable at any other point. Wiring must comply with all applicable local and national codes.

Table 17: Two-Way Ceiling Cassette Indoor Unit Electrical Data.

Model Number	Voltage Range	MCA	MOP	Rated Amps (A)	Power Supply			Power Input (W)		
					Hz	Volts	Phase	Max Cooling	Max Heating	L/M/H at Factory Default
ARNU183TSA4	187-253	0.84	15	0.30	60	208-230	1	70	70	24 / 29 / 34
ARNU243TSA4				0.30						25 / 30 / 40

MCA : Minimum Circuit Ampacity.

MOP : Maximum Overcurrent Protection.

Units are suitable for use on an electrical system where voltage supplied to unit terminals is within the listed range limits.

Select wire size based on the larger MCA value.

Instead of fuse, use circuit breaker.



Figure 24: ARNU183TSA4, ARNU243TSA4 Dimensions.

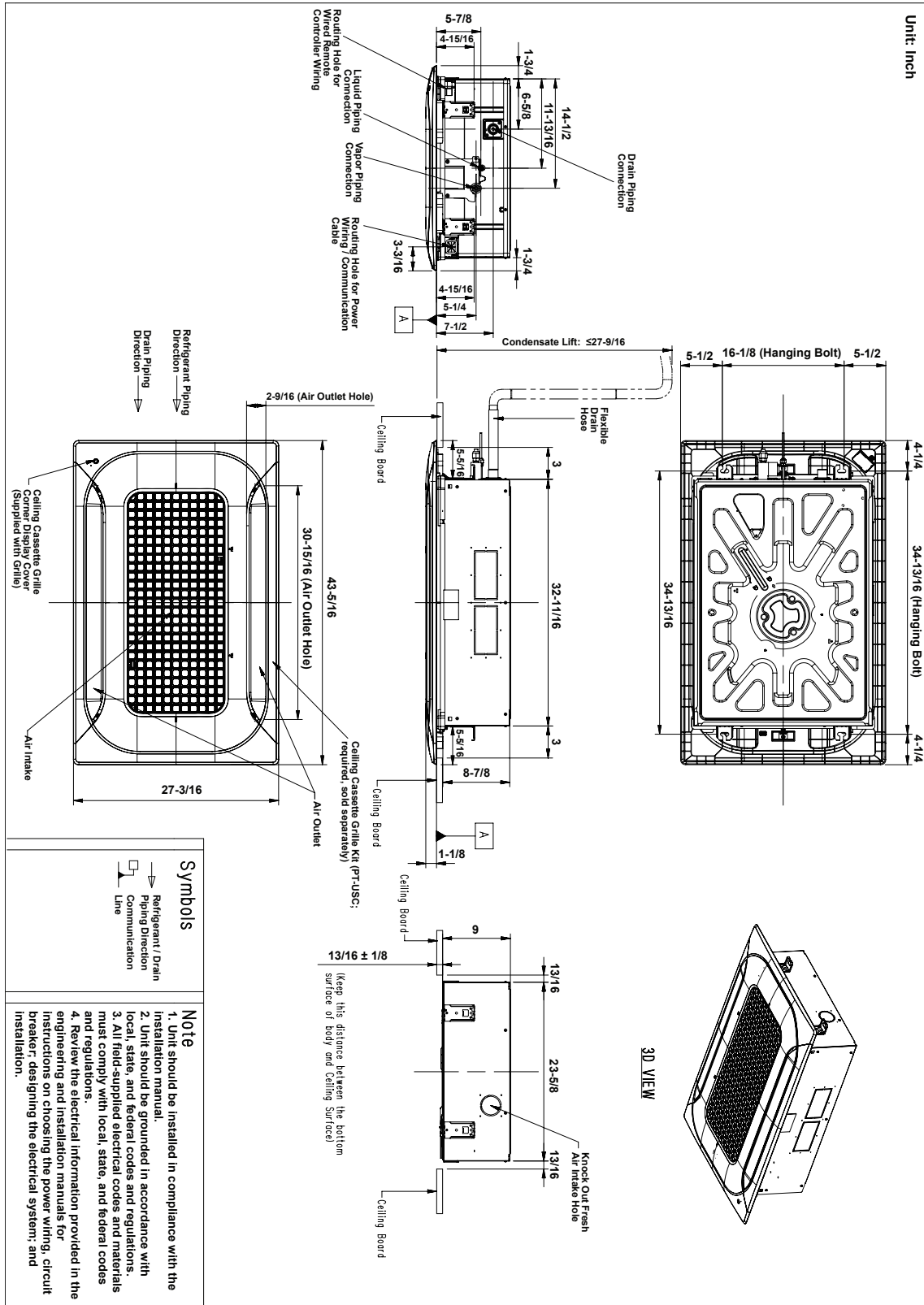

# TWO-WAY CEILING CASSETTE

## Electrical Wiring Diagram

### TS Frame

Figure 25: ARNU183TSA4, ARNU243TSA4 Wiring Diagram.

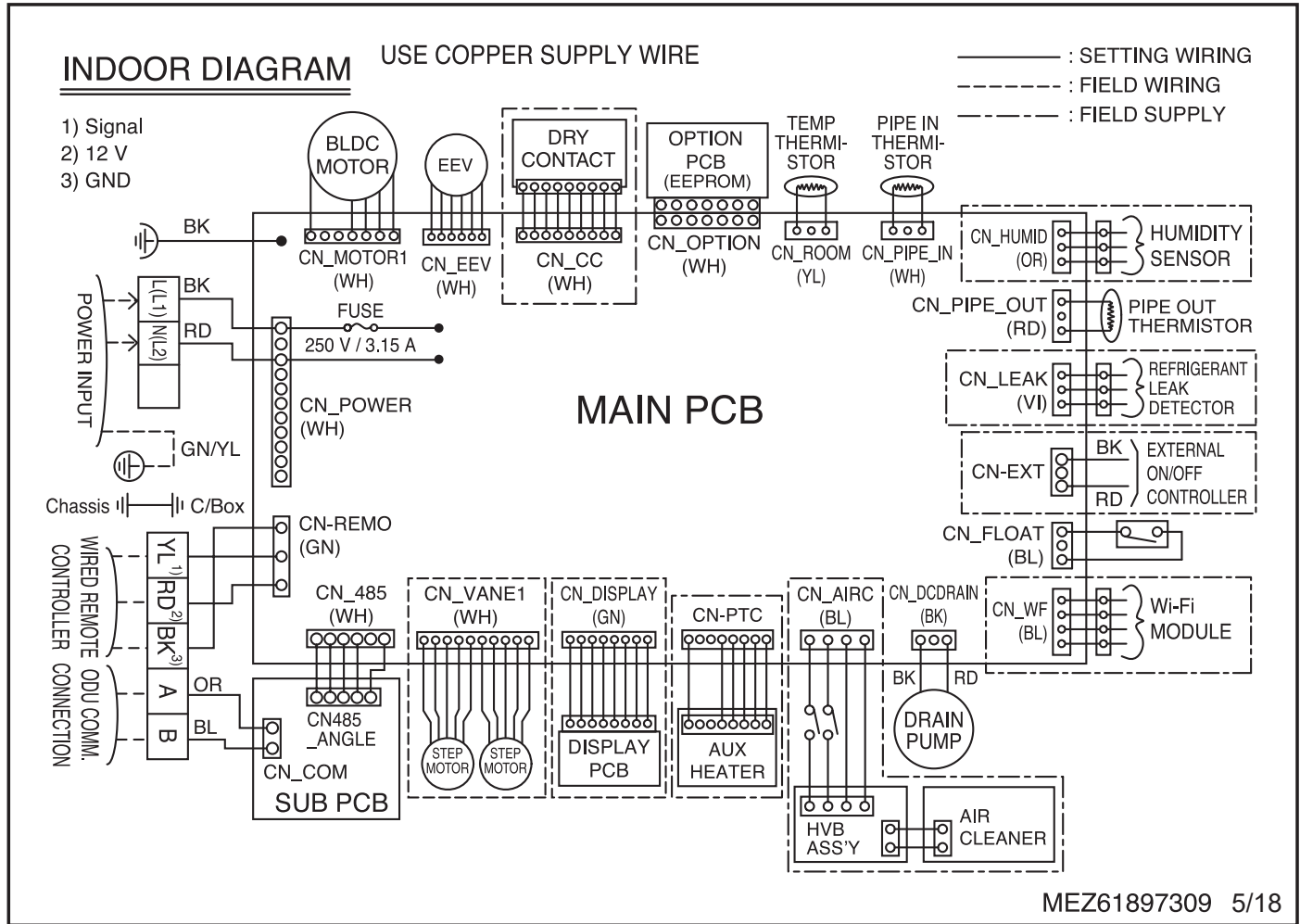

Table 18: TS Frame Wiring Diagram Legend.

Terminal	Purpose	Function
CN-MOTOR1	Fan motor output	Motor output of BLDC
CN-EEV	EEV Output	EEV Control output
CN-CC	Dry Contact	Dry Contact
CN-OPTION	Option PCB (EEPROM)	Option PCB connection
CN-ROOM	Room sensor	Room air thermistor
CN-PIPE_IN	Suction pipe sensor	Pipe in thermistor
CN-HUMID	N/A	N/A
CN-PIPE_OUT	Discharge pipe sensor	Pipe out thermistor
CN-LEAK	Leak sensor	Leak sensor connection
CN_EXT	External on/off controller	External on/off controller connection
CN-FLOAT	Float switch input	Float switch sensing
CN_WF	Wi-Fi module	Wi-Fi module connection
CN_DCDRAIN	Drain pump output	AC output for drain pump
CN-AIRC	Air cleaner	Air cleaner control
CN-PTC	Auxiliary heater	Auxiliary heater connection
CN-DISPLAY	Display	Display of indoor status
CN-VANE1	Step Motor	Step motor output
CN-485	Communication	Connection between indoor and outdoor units
CN-COM	Communication	Connection on Sub PCB between indoor and outdoor units
CN-REMO	Remote controller	Remote control line
CN-POWER	AC Power supply	AC Power line input for indoor controller

Table 19: TS Frame DIP Switch Settings.

DIP Switch Setting		Off	On	Remarks
SW3	GROUP CONTROL	Master	Slave	Group control setting using 7-Day Programmable Controller; selects Master/ Slave on each indoor unit
SW4	DRY CONTACT MODE	Variable	Auto	Sets operation mode for optional Dry Contact accessory 1. Variable: Auto or Manual Mode can be set through 7-Day Programmable Controller or Wireless Remote Controller (factory default setting is Auto if there is no setting) 2. Auto: For Dry Contact, it is always Auto mode

**\*For Gen 4 Multi V two-way ceiling cassette indoor units, DIP switches 1, 2, 5 through 8 must be set to OFF. These DIP switches are used for other models.**

**\*\*To enable Generation 4 features, outdoor unit DIP switch no. 3 must be set to ON. Please refer to the Multi V 5, Multi V IV, Multi V Water IV, Multi V S Engineering Manual for additional information.**

# TWO-WAY CEILING CASSETTE

## Refrigerant Flow Diagram

### TS Frame

Figure 26: TS Piping Diagram.

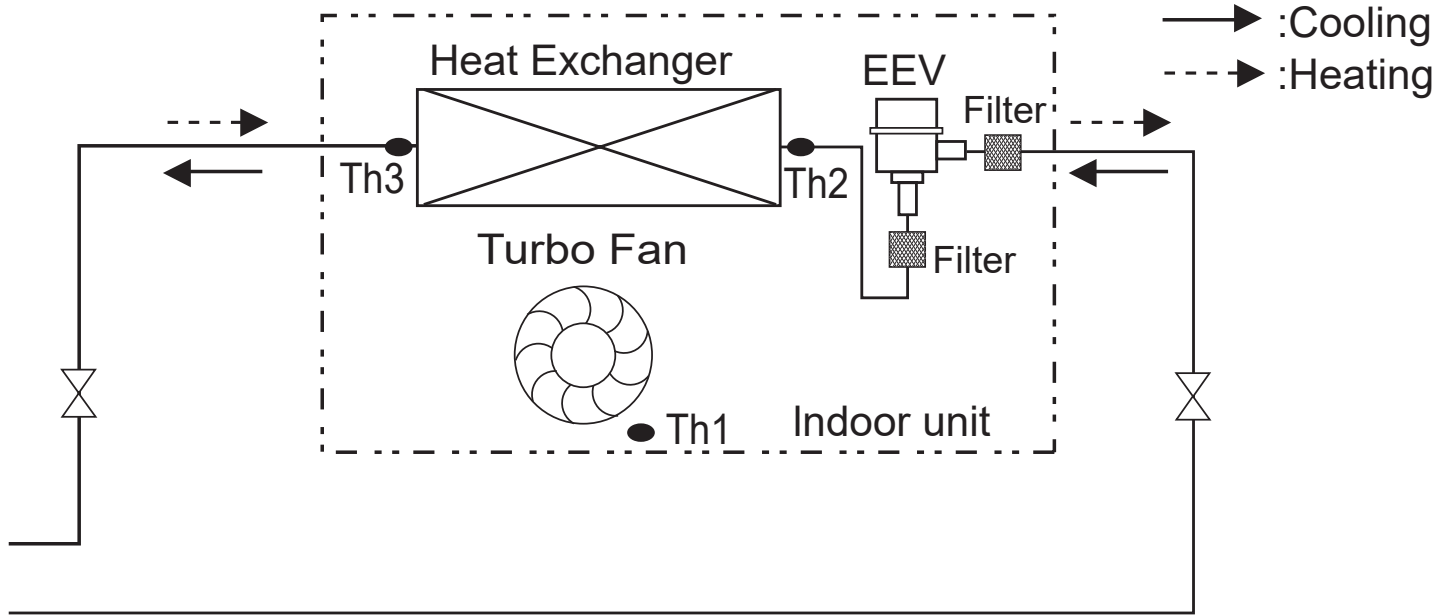

Table 20: TS Frame Refrigerant Pipe Connection Port Diameters.

Model	Liquid (inch)	Gas (inch)
ARNU183TSA4	1/4	1/2
ARNU243TSA4	3/8	5/8

Table 21: TS Frame Thermistors.

Thermistor	Description
TH1	Return air thermistor
TH2	Pipe in thermistor
TH3	Pipe out thermistor



Figure 27: Sound Pressure Measurement Location.

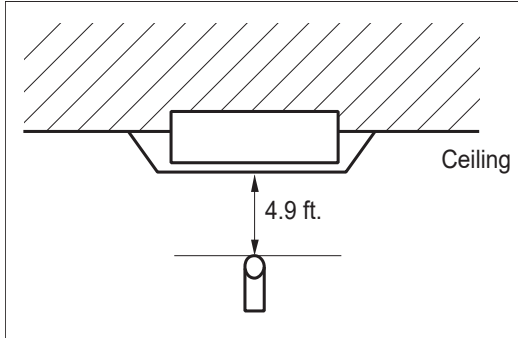

- Measurements are taken 4.9 ft. away from the front of the unit.
- Data is valid under nominal operating conditions.
- Sound pressure levels are measured in dB(A) with a tolerance of  $\pm 3$ .
- Sound pressure levels are tested in an anechoic chamber under ISO Standard 3745.
- Reference acoustic pressure: 0dB = 20 $\mu$ Pa.

Operating Conditions:

- Power source: 220V/60 Hz
- Sound level will vary depending on a range of factors including the construction (acoustic absorption coefficient) of a particular room in which the unit was installed.

Table 22: Two-Way Ceiling Cassette Indoor Unit Sound Pressure Levels.

Model	Sound Levels dB(A)		
	High Fan Speed	Medium Fan Speed	Low Fan Speed
ARNU183TSA4	35.0	33.0	31.0
ARNU243TSA4	40.0	37.0	33.0

Figure 28: ARNU183TSA4 and ARNU243TSA4 Sound Pressure Level Diagrams.

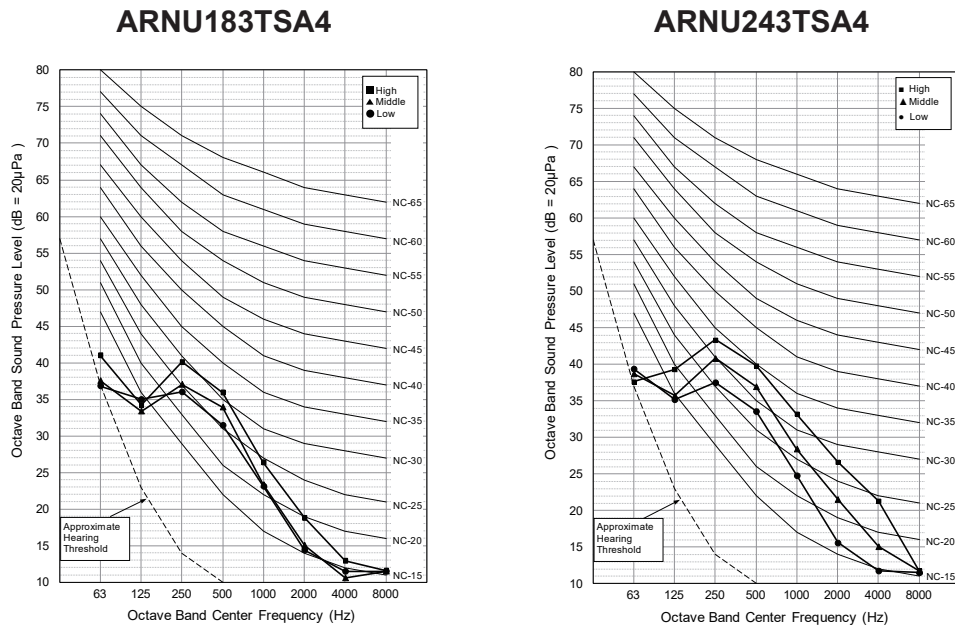

# TWO-WAY CASSETTE

## Acoustic Data

### Sound Power Levels

Table 23: Two-Way Ceiling Cassette Indoor Unit Sound Power Levels.

Model	Sound Levels dB(A)
	High Fan Speed
ARNU183TSA4	44.0
ARNU243TSA4	48.0

- Data is valid under diffuse field conditions.
- Data is valid under nominal operating conditions.
- Sound power level is measured using rated conditions, and tested in a reverberation room per ISO 3741 standards.
- Sound level will vary depending on a range of factors such as construction (acoustic absorption coefficient) of particular area in which the equipment is installed.
- Reference acoustic intensity: 0dB = 10E-6μW/m<sup>2</sup>

Figure 29: ARNU183TSA4 and ARNU243TSA4 Sound Power Level Diagrams.

#### ARNU183TSA4

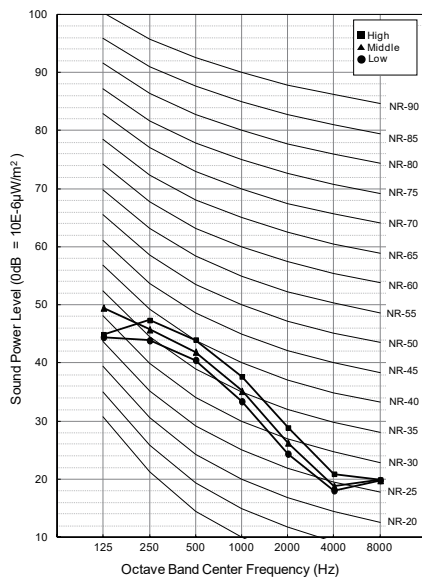

#### ARNU243TSA4

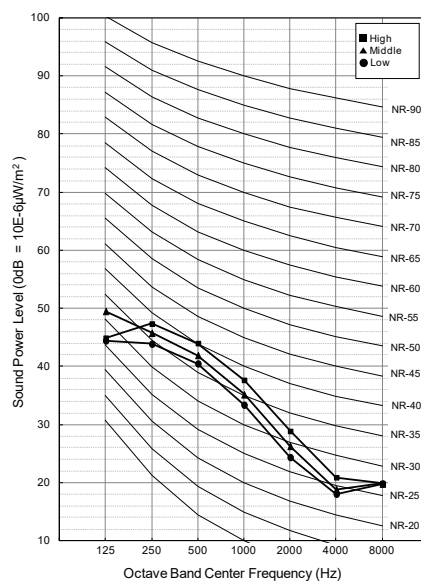

## ARNU183TSA4

### Cooling

Discharge angle: 35°

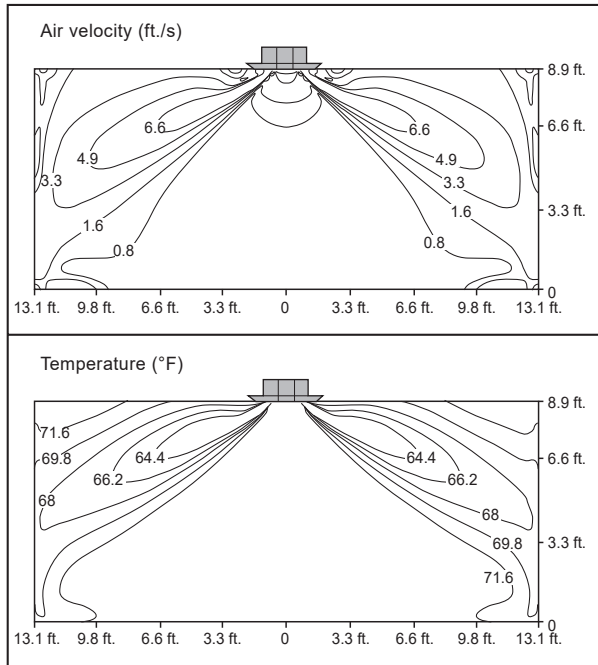

### Cooling

Discharge angle: 40°

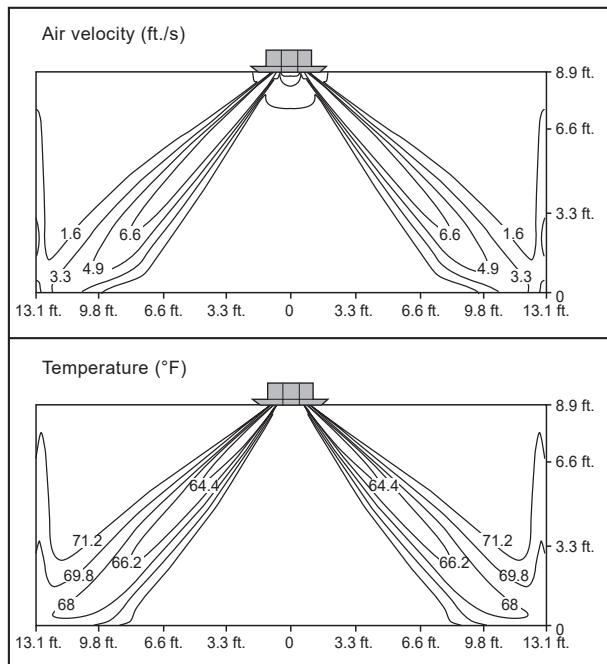

### Heating

Discharge angle: 35°

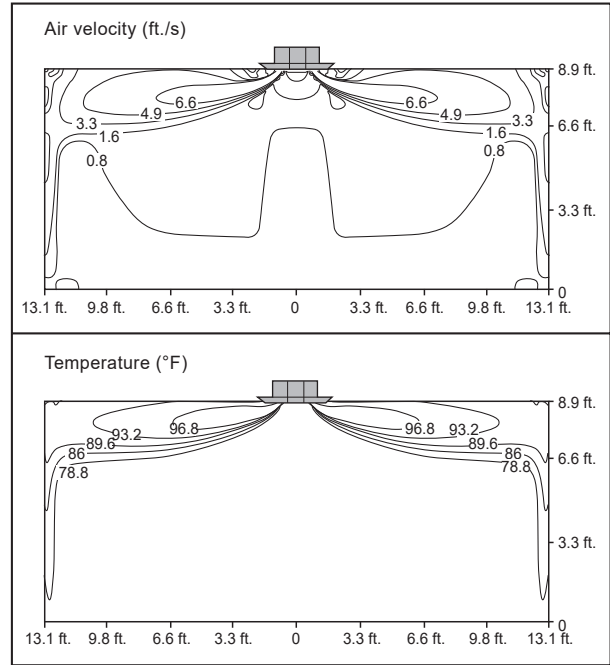

### Heating

Discharge angle: 50°

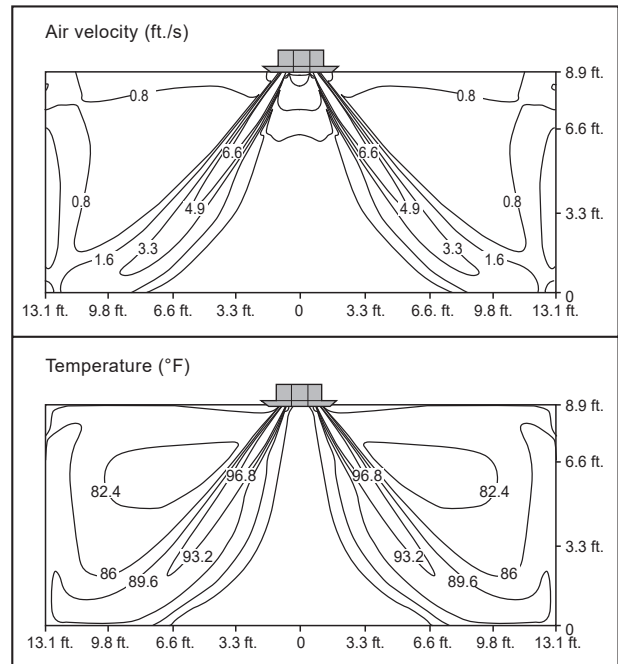

The standard setup height is 8.9 ft. The charts above show the measurement distribution at the ceiling height of 8.9 ft with a high fan operating mode.

# TWO-WAY CEILING CASSETTE



## Air Velocity / Temperature Distribution

ARNU183TSA4

### Cooling

Discharge angle: 80°

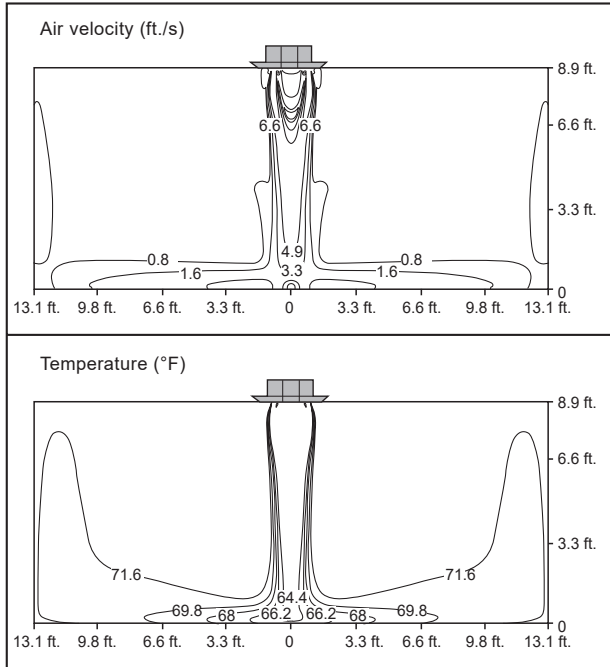

### Heating

Discharge angle: 80°

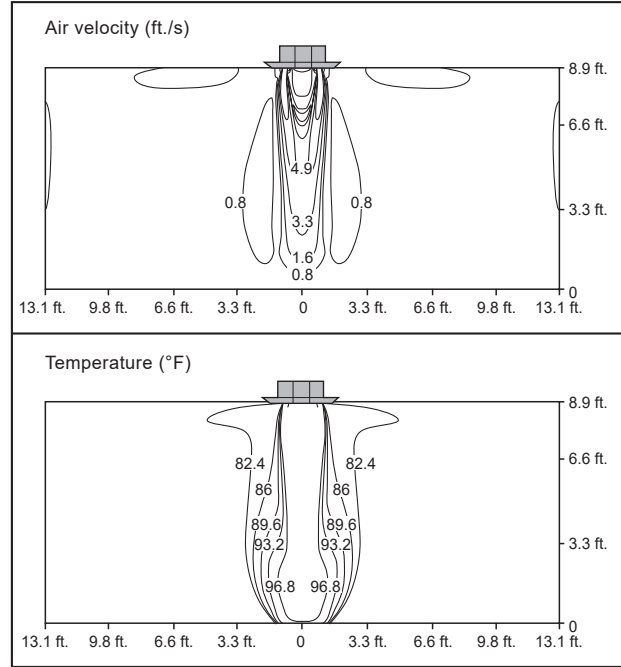

The standard setup height is 8.9 ft. The charts above show the measurement distribution at the ceiling height of 8.9 ft with a high fan operating mode.

**ARNU243TSA4**

**Cooling**

Discharge angle: 35°

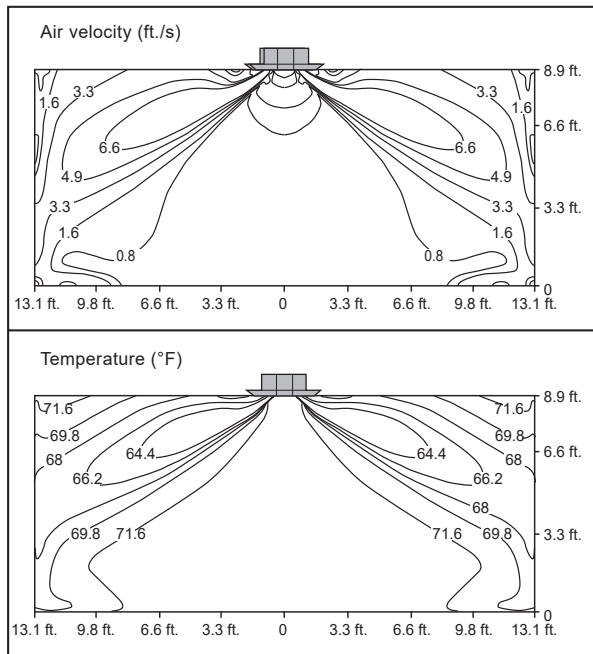

**Heating**

Discharge angle: 35°

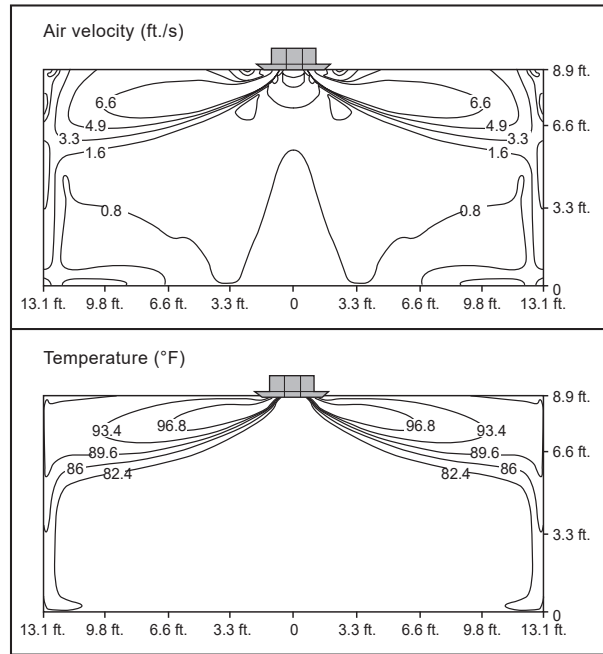

**Cooling**

Discharge angle: 40°

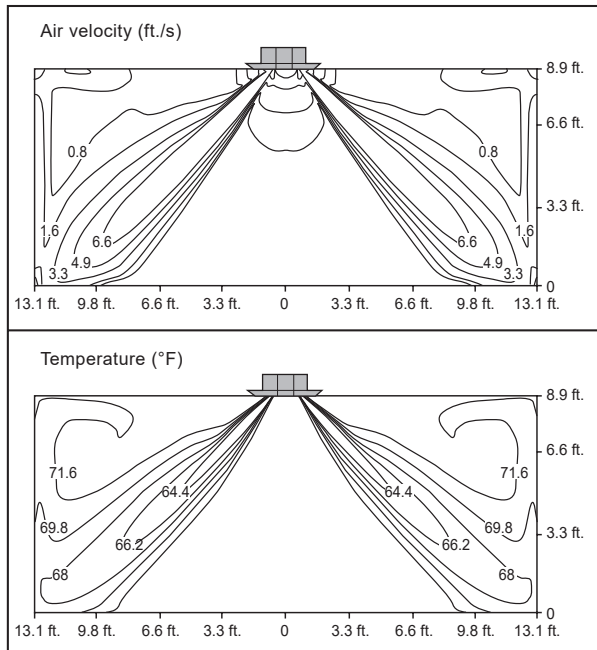

**Heating**

Discharge angle: 50°

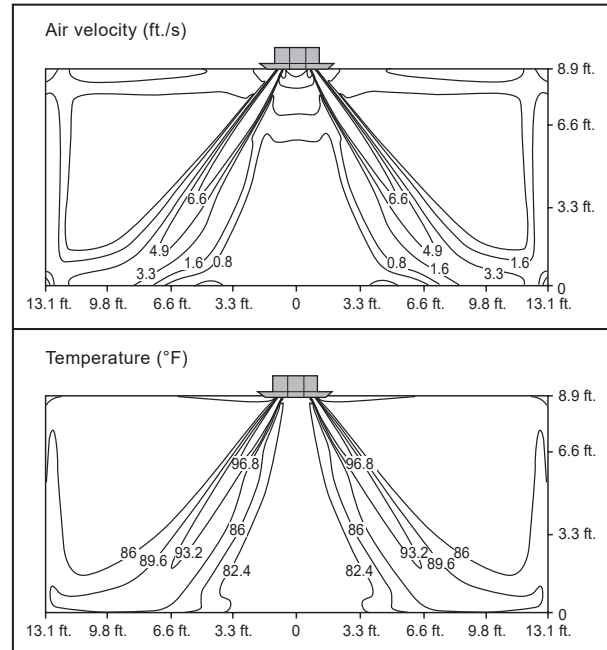

The standard setup height is 8.9 ft. The charts above show the measurement distribution at the ceiling height of 8.9 ft with a high fan operating mode.

# TWO-WAY CEILING CASSETTE



## Air Velocity / Temperature Distribution

### ARNU243TSA4

#### Cooling

Discharge angle: 80°

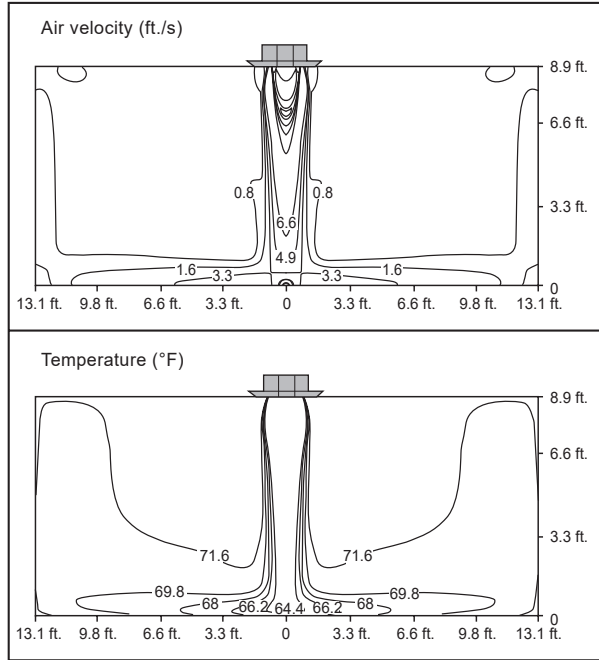

#### Heating

Discharge angle: 80°

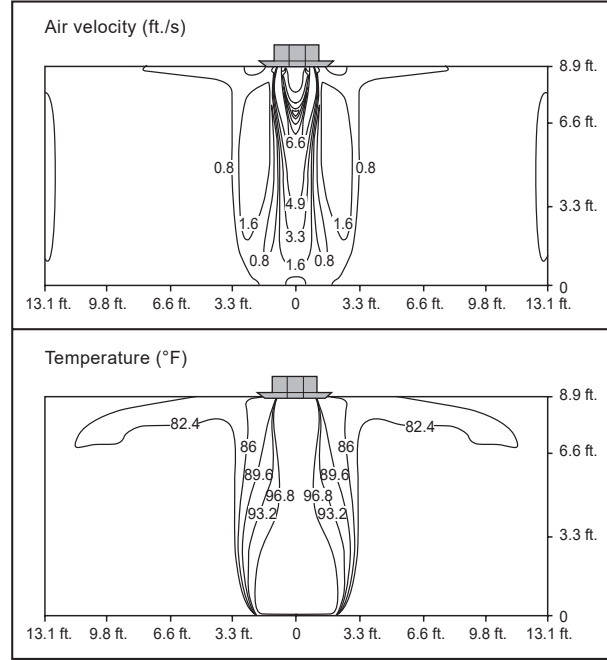

The standard setup height is 8.9 ft. The charts above show the measurement distribution at the ceiling height of 8.9 ft with a high fan operating mode.



# TWO-WAY CEILING CASSETTE



## Heating Capacity Tables

### ARNU183TSA4, ARNU243TSA4

Table 25: ARNU183TSA4, ARNU243TSA4 Heating Capacity Table.

Model No. / Capacity Index	Outdoor Air Temp.		Indoor Air Temperature (°F DB)							
			59	61	64	67	70	73	76	80
	°F DB	°F WB	TC	TC	TC	TC	TC	TC	TC	TC
			MBh	MBh	MBh	MBh	MBh	MBh	MBh	MBh
ARNU183TSA4 / 19.1	-21.6	-22.0	10.9	10.9	10.9	10.9	10.8	10.8	10.8	10.8
	-17.1	-17.5	12.2	12.2	12.2	12.2	12.1	12.1	12.1	12.1
	-12.6	-13	13.6	13.6	13.6	13.6	13.4	13.4	13.4	13.4
	-7	-7.6	14.0	14.0	14.0	14.0	13.8	13.8	13.8	13.8
	-4	-4.4	14.4	14.4	14.4	14.4	14.2	14.2	14.2	14.2
	0	-0.4	14.8	14.8	14.8	14.8	14.8	14.6	14.6	14.6
	5	4.5	16.8	16.6	16.3	16.3	16.3	16.3	16.3	16.3
	10	9	17.4	17.4	17.4	17.2	17.2	17.2	17.2	17.2
	15	14	18.5	18.5	18.5	18.5	18.5	18.5	18.3	18.1
	20	19	19.6	19.6	19.6	19.6	19.1	19.1	18.8	18.6
	25	23	20.4	20.4	20.4	20.4	20.4	20.0	19.8	18.8
	30	28	20.9	20.9	20.9	20.9	20.9	20.4	19.8	18.8
	35	32	21.5	21.5	21.5	21.5	21.3	20.9	19.8	18.8
	40	36	22.4	22.4	22.4	22.4	21.5	20.9	19.8	18.8
	45	41	23.2	23.2	23.2	22.6	21.5	20.9	19.8	18.8
	47	43	24.1	23.9	23.7	22.6	<b>21.5</b>	20.9	19.8	18.8
50	46	25.8	24.7	23.7	22.6	21.5	20.9	19.8	18.8	
55	51	26.3	24.9	23.7	22.6	21.5	20.9	19.8	18.8	
60	56	26.3	24.9	23.7	22.6	21.5	20.9	19.8	18.8	
ARNU243TSA4 / 24.2	-21.6	-22.0	13.9	13.9	13.9	13.9	13.7	13.7	13.7	13.7
	-17.1	-17.5	15.5	15.5	15.5	15.5	15.3	15.3	15.3	15.3
	-12.6	-13	17.2	17.2	17.2	17.2	17.0	17.0	17.0	17.0
	-7	-7.6	17.8	17.8	17.8	17.8	17.5	17.5	17.5	17.5
	-4	-4.4	18.3	18.3	18.3	18.3	18.0	18.0	18.0	18.0
	0	-0.4	18.8	18.8	18.8	18.8	18.8	18.6	18.6	18.6
	5	4.5	21.3	21.0	20.8	20.8	20.8	20.8	20.8	20.8
	10	9	22.1	22.1	22.1	21.8	21.8	21.8	21.8	21.8
	15	14	23.5	23.5	23.5	23.5	23.5	23.5	23.2	22.9
	20	19	24.8	24.8	24.8	24.8	24.3	24.3	23.9	23.6
	25	23	25.9	25.9	25.9	25.9	25.9	25.4	25.1	23.9
	30	28	26.5	26.5	26.5	26.5	26.5	25.9	25.1	23.9
	35	32	27.3	27.3	27.3	27.3	27.0	26.5	25.1	23.9
	40	36	28.4	28.4	28.4	28.4	27.3	26.5	25.1	23.9
	45	41	29.5	29.5	29.5	28.7	27.3	26.5	25.1	23.9
	47	43	30.6	30.3	30.0	28.7	<b>27.3</b>	26.5	25.1	23.9
50	46	32.8	31.4	30.0	28.7	27.3	26.5	25.1	23.9	
55	51	33.4	31.7	30.0	28.7	27.3	26.5	25.1	23.9	
60	56	33.4	31.7	30.0	28.7	27.3	26.5	25.1	23.9	

TC: Total Capacity (MBh).

The System Combination Ratio must be between 50–130%.

Rated capacity is certified under AHRI Standard 1230. Ratings are subject to change without notice. Current certified ratings are available at [www.ahridirectory.org](http://www.ahridirectory.org).

For outdoor unit performance data, see the respective outdoor unit performance data manuals on [www.lghvac.com](http://www.lghvac.com).

Low ambient performance with LGRED® heat technology is included in Multi V 5 air source units produced after February 2019.





Table 26: Optional Accessories for Two-Way Ceiling Cassette Indoor Units.

Accessory	Model Number
Two-Way Ceiling Cassette Grille Kit (One Required)	PT-USC
Auxiliary Heater Kit	PRARH1
Wi-Fi Module	PWFMD200

All accessories are sold separately.

# FOUR-WAY CEILING CASSETTE



2' x 2' Frame



3' x 3' Frame

**Mechanical Specifications on page 59**

**General Data on page 61**

**Electrical Data on page 65**

**External Dimensions on page 66**

**Electrical Wiring Diagrams on page 70**

**Refrigerant Flow Diagrams on page 74**

**Acoustic Data on page 75**

**Air Velocity / Temperature Distribution on page 84**

**Fresh Air Ventilation on page 106**

**Capacity Tables on page 108**

**Optional Accessories on page 125**

### Casing

The case is designed to mount recessed in the ceiling and has a surface-mounted concentric grille on the bottom of the unit. The unit case is manufactured with coated metal. Cold surfaces are covered with a coated polystyrene insulating material. The case is provided with metal ears designed to support the unit weight on four corners. Ears have pre-punched holes designed to accept field-supplied all-thread rod hangers.

### Ventilation Air TQ, TR Frame

The case has a factory designated cutout for the connection of a field-supplied outside air duct. An optional flange kit is available from LG.

### TM, TN Frame

The case has a factory designated cutout for the connection of a field-supplied outside air duct. LG offers two flange kits.

### Supply Air Branch Duct Connections

Factory designated cutouts are marked on the unit case. Branch ducts provide the designer with the ability to duct up to 1/2 the unit airflow capacity to adjacent spaces. The adjacent space must be in the room where the ceiling cassette is installed. It cannot be branched to another room.

### Architectural Filter/Grille

The ceiling cassette assembly is provided with an off-white ABS polymeric resin architectural grille equipped with a tapered trim edge and a hinged, spring clip (screwless) return air filter-grille door.

### TM, TN Frame

The unit case allows access to hanger rods and the inspection of piping through corner access panels on the architectural grille. The optional auto-elevating grille kit is designed to provide motorized ascent/descent of the return air grille/pre-filter assembly a distance of up to 14-3/4 feet allowing easy access to remove and clean the filter.

The kit consists of two lifting mechanisms comprised of an electric motor driven winch with braided steel lifting cables. The winch kit is mounted behind the grille and is not visible during normal unit operation. The auto-elevating return air grille appearance and finish matches that of the architectural grille on similar indoor unit models equipped with the standard hinged filter grilles. The auto-elevating grille control algorithm accepts up, down, and stop control commands from either a wall-mounted or the lift remote controller. The algorithm does not permit the lowering of the grille while the indoor unit fan is operating. The pair of winch controllers work in unison to keep the return air grille level during lift and descent operations and will automatically stop the descent of the return air grille/filter if contact is made with any obstacle.



### Fan Assembly and Control

The indoor unit has a single, direct-drive, turbo fan. The fan wheel is made of high strength ABS HT-700 polymeric resin. The fan motor is a Brushless Digitally-Controlled (BLDC) design with permanently lubricated and sealed ball bearings. The fan motor includes thermal, overcurrent and low RPM protection. The fan/motor assembly is mounted on vibration attenuating rubber grommets. The fan impeller is statically and dynamically balanced. The fan speed is controlled using a microprocessor-based, direct digital control algorithm that provides a high fan speed in cooling thermal ON and low fan speed in cooling thermal OFF, high fan speed in heating thermal ON and fan off in heating thermal OFF. The fan speeds can be field adjusted between low, medium, and high speeds. The fan speed algorithm provides a field selectable, fixed-speed or auto-speed setting that adjusts the fan speed to simulate natural airflow.

### Air Filter

Return air is filtered with a removable, washable filter with anti-fungal treatment. Plasma filter accessories are also available separately.

### Airflow Guide Vanes

The architectural grille has four-directional slot diffusers each equipped with independent oscillating motorized guide vanes designed to change the angle airflow is discharged. Discharge range of motion is 40° in an up/down direction. The unit has a guide vane control algorithm designed to sequentially change the predominant discharge airflow direction in a counterclockwise pattern. The control algorithm also provides the capability of locking each guide vane independently in a field adjusted fixed position. Guide vanes provide airflow in all directions. The ends of each vane are tapered to provide airflow to the space in the direction of the four corners of the architectural grille.

### Microprocessor Controls

The unit is provided with an integrated microprocessor controller capable of performing functions necessary to operate the system without the use of a wall-mounted controller. A temperature thermistor is factory-mounted in the return air stream. All unit operation parameters, excluding the unit operating schedule, are stored in non-volatile memory resident on the unit microprocessor. Operating schedules are stored in select models of the optional, wall-mounted, local, or central controller. The field-supplied communication cable between the indoor unit(s) and outdoor unit is to be a minimum of 18

# FOUR-WAY CEILING CASSETTE

**MULTI V™**

## Mechanical Specifications

AWG, 2 conductor, twisted, stranded, and shielded cable (RS-485), terminated via screw terminals on the control boards. The microprocessor control algorithms provide the following functions: auto addressing, self-diagnostics, auto restart following power restoration, test run, and will operate the indoor unit using one of five operating modes:

1. Auto Changeover (Heat Recovery only)
2. Heating
3. Cooling
4. Dry
5. Fan Only

For Heat Recovery systems the Auto Changeover setting automatically switches control of the indoor unit between cooling and heating modes based on space temperature conditions.

For Heat Pump systems, heated or cooled air delivery is dependent upon outdoor unit operating mode.

In Heating mode, the microprocessor control will activate indoor unit operation when the indoor room temperature falls below setpoint temperature. At which point, a signal is sent to the outdoor unit to begin the heating cycle. The indoor unit fan operation is delayed until coil pipe temperature reaches 76°F. Significant airflow is generated when pipe temperature reaches 80°F. The unit is equipped with an infrared receiver designed to communicate with an LG wireless remote controller. In lieu of wireless remote or factory return air thermistor, screw terminals on the microprocessor circuit board accommodate various models of wall-mounted local controllers and/or a wall-mounted remote temperature sensor. The unit microprocessor is capable of accepting space temperature readings concurrently or individually from either:

1. Wall-mounted wired controller(s)
2. Factory mounted return air thermistor or the optional wall-mounted wired remote temperature sensor.

A single indoor unit has the capability of being controlled by up to two local wired controllers. The microprocessor controls space temperature using the value provided by the temperature sensor sensing a space temperature that is farthest away from the temperature set-point. The microprocessor control provides a cooling or heating mode test cycle that operates the unit for 18 minutes without regard to the space temperature. If the system is provided with an optional wall-mounted, local, or central controller, displayed diagnostic codes are specific, alpha numeric, and provide the service technician with the reason for the code displayed.

*\*To enable Generation 4 features, outdoor unit DIP Switch No. 3 must be set to ON. Please refer to the Multi V 5, Multi V IV, Multi V Water IV, Multi V S Engineering Manual for additional information.*

The indoor units are Wi-Fi compatible with the addition of an LG Wi-Fi module accessory, and can be controlled by LG's Smart ThinQ™ app on a smart device. A field-supplied Wi-Fi network and smart device are required. The Smart ThinQ app is free, and is available for Android™ and iOS. (Android is a trademark of Google LLC.)

### Condensate Lift/Pump

The indoor unit is provided with a factory installed and wired condensate lift/pump capable of providing a maximum 27-1/2 inch lift from the bottom surface of the unit. The lift pump comes with a safety switch that shuts off the indoor unit if condensate rises too high in the drain pan.

### Condensate Drain Pan

The condensate drain pan is constructed of EPS (expandable polystyrene resin).

### Coil

The indoor unit coil is constructed with grooved design copper tubes with slit coil fins, one (1) to two (2) rows, eighteen (18) to nineteen (19) fins per inch.

### Controls Features

- Auto changeover (Heat Recovery only)
- Auto operation
- Auto restart
- External on/off control
- Dual thermistor control
- Dual set-point control
- Filter life display
- Multiple auxiliary heater applications
- Group control
- High ceiling
- Hot start
- Self diagnostics
- Timer (on / off)
- Weekly schedule
- Auto direction / swing (up / down)
- Fan speed control
- Swirl wind (alternating vanes)
- Jet cool (fast cooling)
- Wi-Fi compatible
- Auto fan
- Leak detection

Table 27: Four-Way Ceiling Cassette (2' x 2' TR and TQ Frames) Indoor Unit General Data.

Model No.	ARNU053TRD4	ARNU073TRD4	ARNU093TRD4	ARNU123TRD4	ARNU153TQD4	ARNU183TQD4
<b>Cooling Mode Performance</b>						
Capacity (Btu/h)	5,500	7,500	9,600	12,300	15,400	19,100
Max Power Input <sup>1</sup> (W)	30	30	30	30	30	30
L/M/H Power at Factory Default (W)	11 / 12 / 13	11 / 12 / 13	12 / 13 / 14	13 / 15 / 17	18 / 21 / 24	19 / 22 / 25
<b>Heating Mode Performance</b>						
Capacity (Btu/h)	6,100	8,500	10,900	13,600	17,100	21,500
Max Power Input <sup>1</sup> (W)	30	30	30	30	30	30
L/M/H Power at Factory Default (W)	11 / 12 / 13	11 / 12 / 13	12 / 13 / 14	13 / 15 / 17	18 / 21 / 24	19 / 22 / 25
<b>Entering Mixed Air</b>						
Cooling Max. (°F WB)	76	76	76	76	76	76
Heating Min. (°F DB)	59	59	59	59	59	59
<b>Unit Data</b>						
Refrigerant Type <sup>2</sup>	R410A	R410A	R410A	R410A	R410A	R410A
Refrigerant Control	EEV	EEV	EEV	EEV	EEV	EEV
Sound Pressure <sup>3</sup> dB(A) (H/M/L)	29 / 27 / 26	29 / 27 / 26	30 / 29 / 27	32 / 30 / 27	36 / 34 / 32	37 / 35 / 34
Net Unit Weight (lbs.)	29	29	32	32	35	35
Shipping Weight (lbs.)	34	34	38	38	40	40
Grille Weight (lbs)	7	7	7	7	7	7
Grille Shipping Weight (lbs)	11	11	11	11	11	11
Communication Cable <sup>4</sup> (No. x AWG)	2 x 18	2 x 18	2 x 18	2 x 18	2 x 18	2 x 18
<b>Fan</b>						
Type	Turbo	Turbo	Turbo	Turbo	Turbo	Turbo
Quantity	1	1	1	1	1	1
Motor/Drive	Brushless Digitally Controlled / Direct					
Airflow Rate H/M/L (CFM)	265 / 247 / 212	265 / 247 / 212	283 / 265 / 251	307 / 283 / 247	388 / 353 / 328	396 / 388 / 353
<b>Piping</b>						
Liquid Line (in., O.D.)	1/4 Flare	1/4 Flare	1/4 Flare	1/4 Flare	1/4 Flare	1/4 Flare
Vapor Line (in., O.D.)	1/2 Flare	1/2 Flare	1/2 Flare	1/2 Flare	1/2 Flare	1/2 Flare
Condensate Line (in., I.D.)	1	1	1	1	1	1

EEV: Electronic Expansion Valve

Power wiring is field supplied and must comply with the applicable local and national codes. See page 61 for detailed electrical data.

This unit comes with a dry nitrogen charge.

All capacities are net with a combination ratio between 95-105%.

Rated capacity is certified under AHRI Standard 1230. Ratings are subject to change without notice. Current certified ratings are available at [www.ahridirectory.org](http://www.ahridirectory.org).

Low ambient performance with LGRED<sup>®</sup> heat technology is included in Multi V 5 air source units produced after February 2019.

<sup>1</sup>Max power Input is rated at maximum setting value.

<sup>2</sup>Take appropriate actions at the end of HVAC equipment life to recover, recycle, reclaim or destroy R410A refrigerant according to applicable regulations (40 CFR Part 82, Subpart F) under section 608 of CAA.

<sup>3</sup>Sound Pressure levels are tested in an anechoic chamber under ISO Standard 3745.

<sup>4</sup>Communication cable between Master ODU to IDUs / HRUs to be 18 AWG, 2-conductor, twisted, stranded, shielded. Ensure the communication cable shield is properly grounded to the Master ODU chassis only. ⚠ Do not ground the ODU to IDUs / HRUs communication cable at any other point. Wiring must comply with all applicable local and national codes.

# FOUR-WAY CEILING CASSETTE



## General Data

Table 28: Four-Way Ceiling Cassette (3' x 3' TN Frames) Indoor Unit General Data.

Model No.	ARNU073TNA4	ARNU093TNA4	ARNU123TNA4	ARNU153TNA4
<i>Cooling Mode Performance</i>				
Capacity (Btu/h)	7,500	9,600	12,300	15,400
Max Power Input <sup>1</sup> (W)	144	144	144	144
L/M/H Power Input at Factory Default (W)	12 / 15 / 18	12 / 15 / 19	14 / 17 / 22	14 / 17 / 25
<i>Heating Mode Performance</i>				
Capacity (Btu/h)	8,500	10,900	13,600	17,100
Max Power Input <sup>1</sup> (W)	144	144	144	144
L/M/H Power Input at Factory Default (W)	12 / 15 / 18	12 / 15 / 19	14 / 17 / 22	14 / 17 / 25
<i>Entering Mixed Air</i>				
Cooling Max (°F WB)	76	76	76	76
Heating Min (°F DB)	59	59	59	59
<i>Unit Data</i>				
Refrigerant Type <sup>2</sup>	R410A	R410A	R410A	R410A
Refrigerant Control	EEV	EEV	EEV	EEV
Sound Pressure <sup>3</sup> dB(A) (H/M/L)	29 / 26 / 24	29 / 26 / 24	31 / 29 / 26	32 / 29 / 26
Net Unit Weight (lbs.)	53.6	53.6	53.6	53.6
Shipping Weight (lbs.)	66.1	66.1	66.1	66.1
Grill Weight (lbs)	13	13	13	13
Grill Shipping Weight (lbs)	20	20	20	20
Communication Cable <sup>4</sup> (No. x AWG)	2 x 18	2 x 18	2 x 18	2 x 18
<i>Fan</i>				
Type	Turbo	Turbo	Turbo	Turbo
Quantity	1	1	1	1
Motor/Drive	Brushless Digitally Controlled / Direct			
Airflow Rate H/M/L (CFM)	459 / 424 / 388	477 / 424 / 388	494 / 459 / 424	530 / 459 / 424
<i>Piping</i>				
Liquid Line (in., O.D.)	3/8 Flare	3/8 Flare	3/8 Flare	3/8 Flare
Vapor Line (in., O.D.)	5/8 Flare	5/8 Flare	5/8 Flare	5/8 Flare
Condensate Line (in., I.D.)	1	1	1	1

EEV: Electronic Expansion Valve

Power wiring is field supplied and must comply with the applicable local and national codes. See page 61 for detailed electrical data.

This unit comes with a dry nitrogen charge.

All capacities are net with a combination ratio between 95-105%.

Rated capacity is certified under AHRI Standard 1230. Ratings are subject to change without notice. Current certified ratings are available at [www.ahridirectory.org](http://www.ahridirectory.org).

Low ambient performance with LGRED<sup>®</sup> heat technology is included in Multi V 5 air source units produced after February 2019.

<sup>1</sup>Max power Input is rated at maximum setting value.

<sup>2</sup>Take appropriate actions at the end of HVAC equipment life to recover, recycle, reclaim or destroy R410A refrigerant according to applicable regulations (40 CFR Part 82, Subpart F) under section 608 of CAA.

<sup>3</sup>Sound Pressure levels are tested in an anechoic chamber under ISO Standard 3745.

<sup>4</sup>Communication cable between Master ODU to IDUs / HRUs to be 18 AWG, 2-conductor, twisted, stranded, shielded. Ensure the communication cable shield is properly grounded to the Master ODU chassis only. ⚠ Do not ground the ODU to IDUs / HRUs communication cable at any other point. Wiring must comply with all applicable local and national codes.

Table 29: Four-Way Ceiling Cassette (3' x 3' TN Frames) Indoor Unit General Data, continued.

Model No.	ARNU183TNA4	ARNU243TNA4
<i>Cooling Mode Performance</i>		
Capacity (Btu/h)	19,100	24,200
Max Power Input <sup>1</sup> (W)	144	144
L/M/H Power Input at Factory Default (W)	14 / 18 / 27	30 / 38 / 51
<i>Heating Mode Performance</i>		
Capacity (Btu/h)	21,500	27,300
Max Power Input <sup>1</sup> (W)	144	144
L/M/H Power Input at Factory Default (W)	14 / 18 / 27	30 / 38 / 51
<i>Entering Mixed Air</i>		
Cooling Max (°F WB)	76	76
Heating Min (°F DB)	59	59
<i>Unit Data</i>		
Refrigerant Type <sup>2</sup>	R410A	R410A
Refrigerant Control	EEV	EEV
Sound Pressure <sup>3</sup> dB(A) (H/M/L)	34 / 30 / 26	40 / 38 / 35
Net Unit Weight (lbs.)	53.6	53.6
Shipping Weight (lbs.)	66.1	66.1
Grill Weight (lbs)	13	13
Grill Shipping Weight (lbs)	20	20
Communication Cable <sup>4</sup> (No. x AWG)	2 x 18	2 x 18
<i>Fan</i>		
Type	Turbo	Turbo
Quantity	1	1
Motor/Drive	Brushless Digitally Controlled / Direct	
Airflow Rate H/M/L (CFM)	565 / 530 / 424	742 / 671 / 600
<i>Piping</i>		
Liquid Line (in., O.D.)	3/8 Flare	3/8 Flare
Vapor Line (in., O.D.)	5/8 Flare	5/8 Flare
Condensate Line (in., I.D.)	1	1

EEV: Electronic Expansion Valve  
 Power wiring is field supplied and must comply with the applicable local and national codes. See page 61 for detailed electrical data.  
 This unit comes with a dry nitrogen charge.  
 All capacities are net with a combination ratio between 95-105%.  
 Rated capacity is certified under AHRI Standard 1230. Ratings are subject to change without notice. Current certified ratings are available at [www.ahridirectory.org](http://www.ahridirectory.org).  
 Low ambient performance with LGRED<sup>®</sup> heat technology is included in Multi V 5 air source units produced after February 2019.

<sup>1</sup>Max power Input is rated at maximum setting value..  
<sup>2</sup>Take appropriate actions at the end of HVAC equipment life to recover, recycle, reclaim or destroy R410A refrigerant according to applicable regulations (40 CFR Part 82, Subpart F) under section 608 of CAA.  
<sup>3</sup>Sound Pressure levels are tested in an anechoic chamber under ISO Standard 3745.  
<sup>4</sup>Communication cable between Master ODU to IDUs / HRUs to be 18 AWG, 2-conductor, twisted, stranded, shielded. Ensure the communication cable shield is properly grounded to the Master ODU chassis only. Ⓞ Do not ground the ODU to IDUs / HRUs communication cable at any other point. Wiring must comply with all applicable local and national codes.

# FOUR-WAY CEILING CASSETTE



## General Data

Table 30: Four-Way Ceiling Cassette (3' x 3' TM Frames) Indoor Unit General Data.

Model No.	ARNU283TMA4	ARNU363TMA4	ARNU423TMC4	ARNU483TMC4
<i>Cooling Mode Performance</i>				
Capacity (Btu/h)	28,000	36,200	42,000	48,100
Max Power Input <sup>1</sup> (W)	144	144	144	144
L/M/H Power Input at Factory Default (W)	31 / 43 / 52	34 / 47 / 64	53 / 75 / 104	66 / 80 / 120
<i>Heating Mode Performance</i>				
Capacity (Btu/h)	31,500	40,600	43,800	51,200
Max Power Input <sup>1</sup> (W)	144	144	144	144
L/M/H Power Input at Factory Default (W)	31 / 43 / 52	34 / 47 / 64	53 / 75 / 104	66 / 80 / 120
<i>Entering Mixed Air</i>				
Cooling Max (°F WB)	76	76	76	76
Heating Min (°F DB)	59	59	59	59
<i>Unit Data</i>				
Refrigerant Type <sup>2</sup>	R410A	R410A	R410A	R410A
Refrigerant Control	EEV	EEV	EEV	EEV
Sound Pressure <sup>3</sup> dB(A) (H/M/L)	41 / 39 / 35	44 / 41 / 37	45 / 41 / 38	46 / 42 / 40
Net Unit Weight (lbs.)	58.4	58.4	59	59
Shipping Weight (lbs.)	70.5	70.5	69	69
Grill Weight (lbs)	13	13	13	13
Grill Shipping Weight (lbs)	20	20	20	20
Communication Cable <sup>4</sup> (No. x AWG)	2 x 18	2 x 18	2 x 18	2 x 18
<i>Fan</i>				
Type	Turbo	Turbo	Turbo	Turbo
Quantity	1	1	1	1
Motor/Drive	Brushless Digitally Controlled Direct			
Airflow Rate H/M/L (CFM)	812 / 741 / 635	918 / 812 / 706	1,059 / 918 / 812	1,130 / 953 / 883
<i>Piping</i>				
Liquid Line (in., O.D.)	3/8 Flare	3/8 Flare	3/8 Flare	3/8 Flare
Vapor Line (in., O.D.)	5/8 Flare	5/8 Flare	5/8 Flare	5/8 Flare
Condensate Line (in., I.D.)	1	1	1	1

EEV: Electronic Expansion Valve

Power wiring is field supplied and must comply with the applicable local and national codes. See page 61 for detailed electrical data.

This unit comes with a dry nitrogen charge.

All capacities are net with a combination ratio between 95-105%.

Rated capacity is certified under AHRI Standard 1230. Ratings are subject to change without notice. Current certified ratings are available at [www.ahridirectory.org](http://www.ahridirectory.org).

Low ambient performance with LGRED<sup>®</sup> heat technology is included in Multi V 5 air source units produced after February 2019.

<sup>1</sup>Max power Input is rated at maximum setting value.

<sup>2</sup>Take appropriate actions at the end of HVAC equipment life to recover, recycle, reclaim or destroy R410A refrigerant according to applicable regulations (40 CFR Part 82, Subpart F) under section 608 of CAA.

<sup>3</sup>Sound Pressure levels are tested in an anechoic chamber under ISO Standard 3745.

<sup>4</sup>Communication cable between Master ODU to IDUs / HRUs to be 18 AWG, 2-conductor, twisted, stranded, shielded. Ensure the communication cable shield is properly grounded to the Master ODU chassis only. ⚡ Do not ground the ODU to IDUs / HRUs communication cable at any other point. Wiring must comply with all applicable local and national codes.



Table 31: Four-Way Ceiling Cassette (2' x 2' and 3' x 3' Frames) Indoor Unit Electrical Data.

Model	Voltage Range	MCA	MOP	Rated Amps (A)	Power Supply			Power Input (W)		
					Hz	Volts	Phase	Max Cooling	Max Heating	L / M / H at Factory Default
<b>2' x 2' Frames</b>										
ARNU053TRD4	187-253	0.25	15	0.2	60	208-230	1	30	30	11 / 12 / 13
ARNU073TRD4		0.25		0.2				30	30	11 / 12 / 13
ARNU093TRD4		0.25		0.2				30	30	12 / 13 / 14
ARNU123TRD4		0.25		0.2				30	30	13 / 15 / 17
ARNU153TQD4		0.25		0.2				30	30	18 / 21 / 24
ARNU183TQD4		0.25		0.2				30	30	19 / 22 / 25
<b>3' x 3' Frames (TN, 9-11/16" High)</b>										
ARNU073TNA4	187-253	0.71	15	0.56	60	208-230	1	144	144	12 / 15 / 18
ARNU093TNA4		0.71		0.56				144	144	12 / 15 / 19
ARNU123TNA4		0.71		0.56				144	144	14 / 17 / 22
ARNU153TNA4		0.71		0.56				144	144	14 / 17 / 25
ARNU183TNA4		0.71		0.56				144	144	14 / 18 / 27
ARNU243TNA4		0.71		0.56				144	144	30 / 38 / 51
<b>3' x 3' Frames (TM, 11-5/16" High)</b>										
ARNU283TMA4	187-253	1.6	15	1.3	60	208-230	1	144	144	31 / 43 / 52
ARNU363TMA4		1.6		1.3				144	144	34 / 47 / 64
ARNU423TMC4		1.6		1.3				144	144	53 / 75 / 104
ARNU483TMC4		1.6		1.3				144	144	66 / 80 / 120

MCA : Minimum Circuit Ampacity.  
MOP : Maximum Overcurrent Protection.

Units are suitable for use on an electrical system where voltage supplied to unit terminals is within the listed range limits.  
Select wire size based on the larger MCA value.  
Instead of a fuse, use the circuit breaker.

# FOUR-WAY CEILING CASSETTE



## External Dimensions

### TR Frame

Figure 30: ARNU053TRD4, ARNU073TRD4, ARNU093TRD4, ARNU123TRD4 Dimensions.

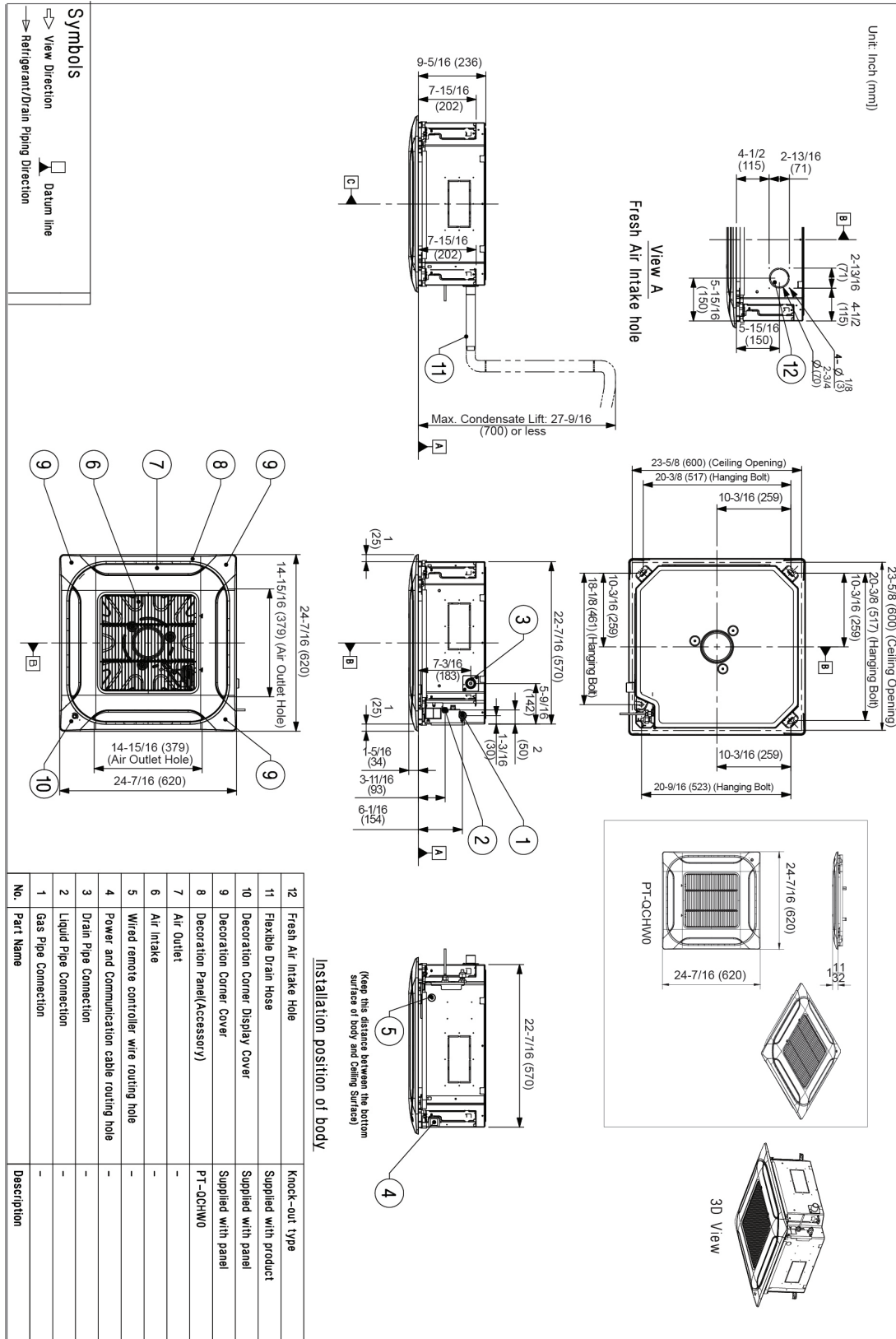
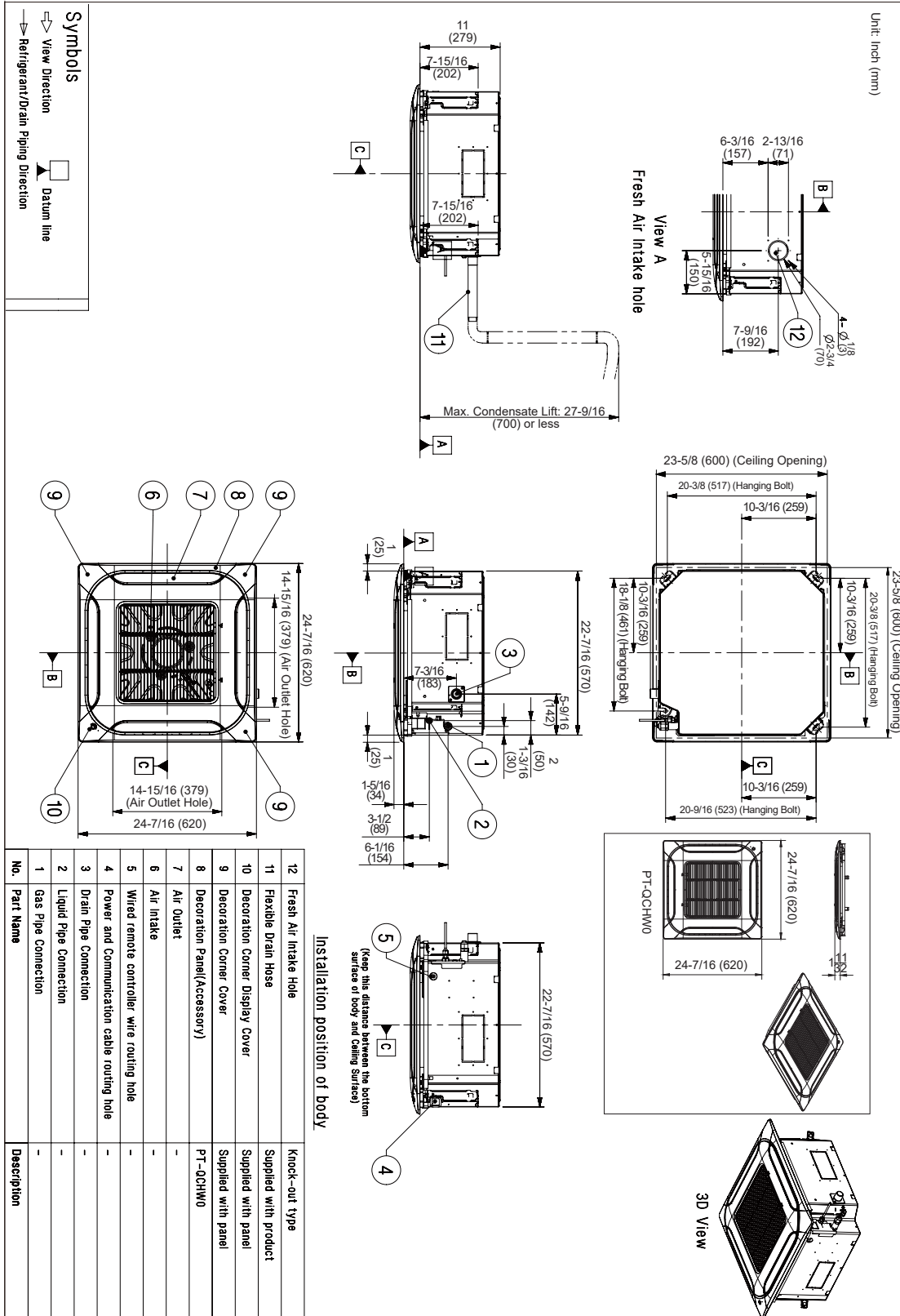

Figure 31: ARNU153TQD4, ARNU183TQD4 Dimensions.



# FOUR-WAY CEILING CASSETTE



## External Dimensions

### TN Frame

Figure 32: ARNU073TNA4, ARNU093TNA4, ARNU123TNA4, ARNU153TNA4, ARNU183TNA4, and ARNU243TNA4 Dimensions.

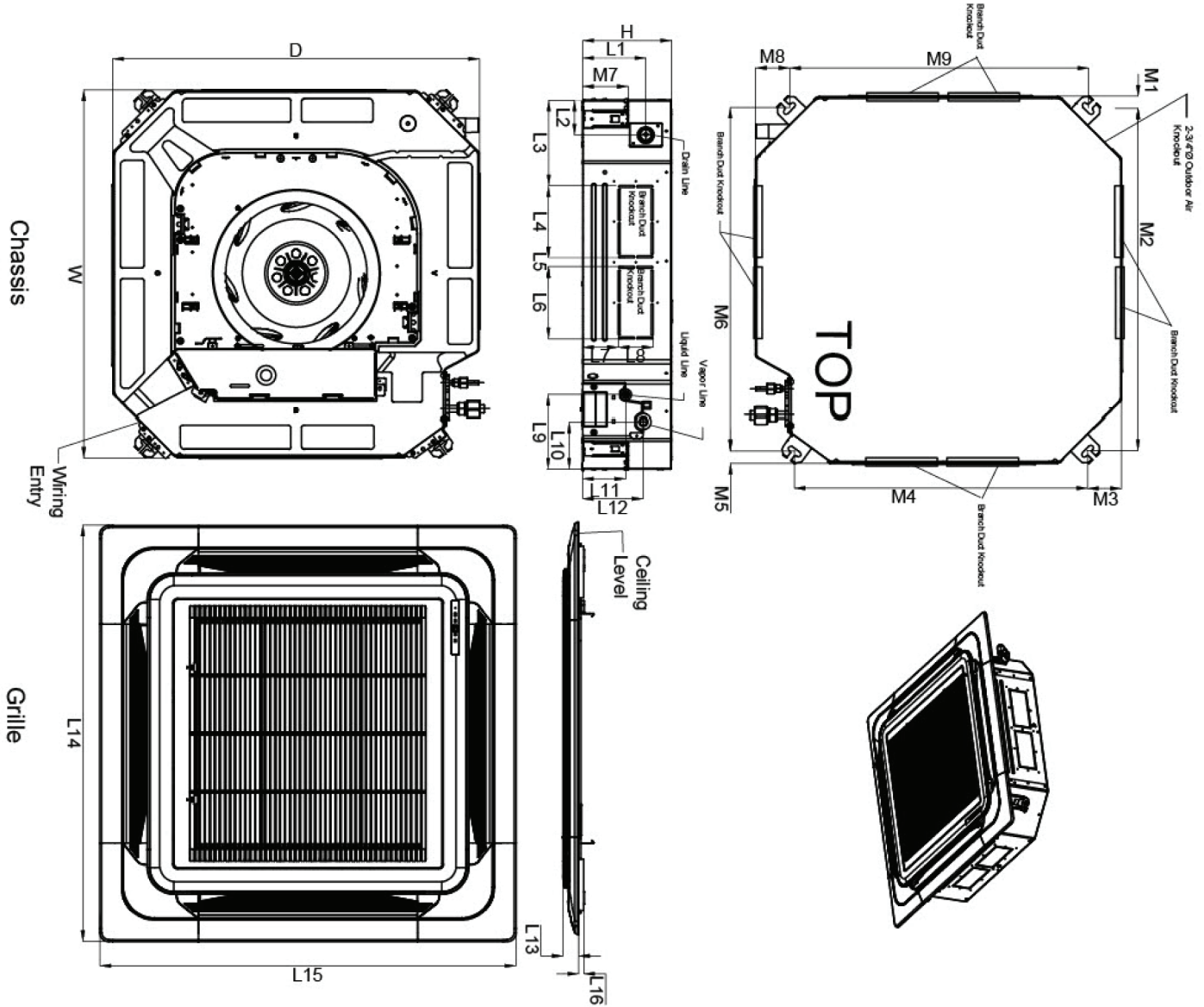

W	33-1/16"
H	9-11/16"
D	33-1/16"
L1	6-11/16"
L2	3-1/8"
L3	7-11/16"
L4	6-1/2"
L5	3/4"
L6	6-1/2"
L7	3-11/16"
L8	3-15/16"
L9	6-5/8"
L10	4-5/16"
L11	3-15/16"
L12	5-7/16"
L13	1-7/16"
L14	37-3/8"
L15	37-3/8"
L16	1/2"
M1	1-1/16"
M2	30-15/16"
M3	3-1/16"
M4	26-7/16"
M5	1-1/16"
M6	30-15/16"
M7	4-1/8"
M8	3-1/16"
M9	26-15/16"

Note - All dimensions have a tolerance of ± 0.25 in.

Figure 33: ARNU283TMA4, ARNU363TMA4, ARNU423TMC4, and ARNU483TMC4 Dimensions.

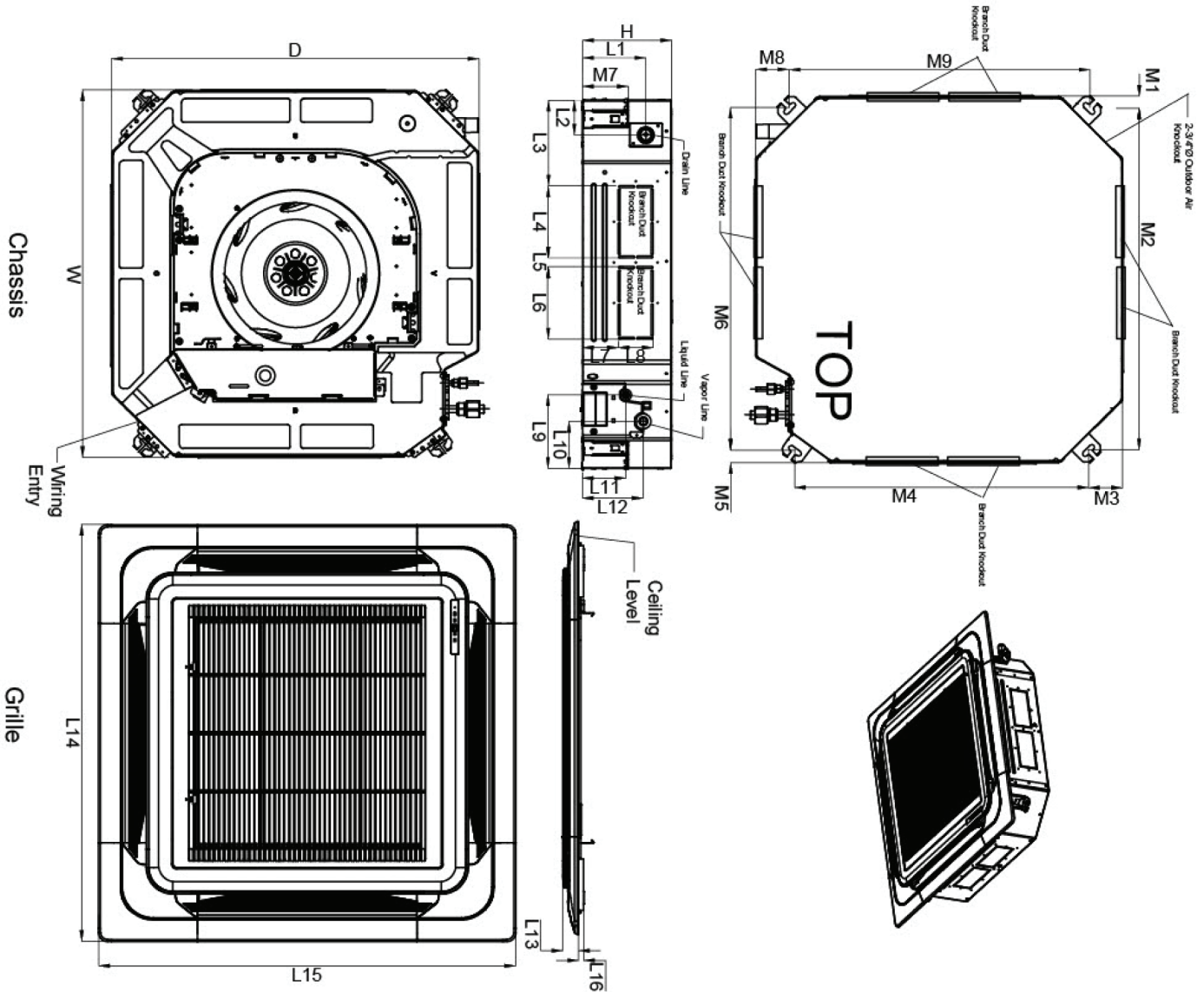

W	33-1/16"
H	11-5/16"
D	33-1/16"
L1	8-9/16"
L2	3-1/8"
L3	7-11/16"
L4	6-1/2"
L5	3/4"
L6	6-1/2"
L7	4-1/16"
L8	3-15/16"
L9	6-5/8"
L10	4-5/16"
L11	4"
L12	5-1/2"
L13	1-7/16"
L14	37-3/8"
L15	37-3/8"
L16	1/2"
M1	1-1/16"
M2	30-15/16"
M3	3-1/16"
M4	26-7/16"
M5	1-1/16"
M6	30-15/16"
M7	4-1/8"
M8	3-1/16"
M9	26-15/16"

Note - All dimensions have a tolerance of ± 0.25 in.

# FOUR-WAY CEILING CASSETTE

## Electrical Wiring Diagram TR and TQ Frames

Figure 34: ARNU053TRD4, ARNU073TRD4, ARNU093TRD4, ARNU123TRD4, ARNU153TQD4, ARNU183TQD4 Wiring Diagram.

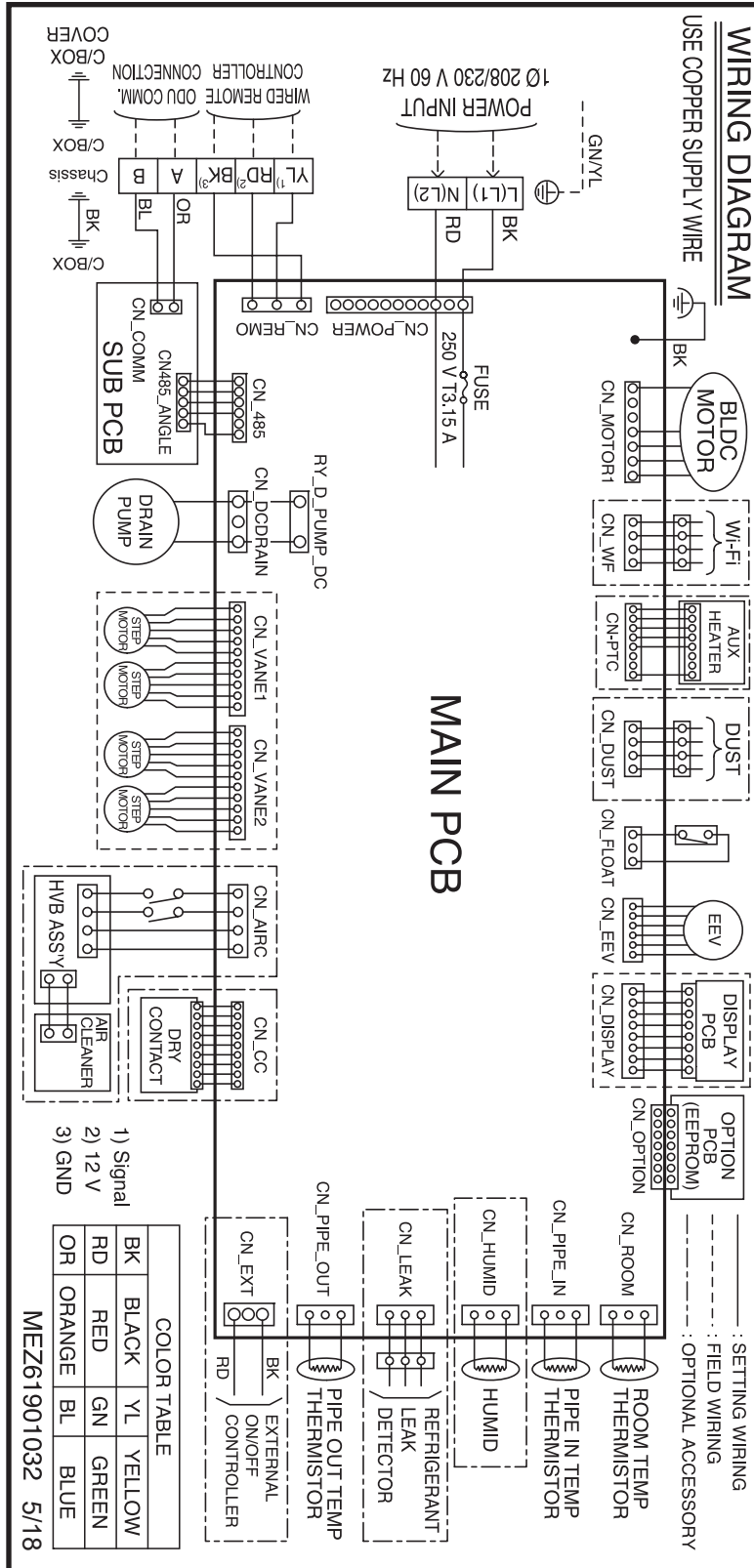

Table 32: TR / TQ Frame Wiring Diagram Legend.

Terminal	Purpose	Function
CN_MOTOR1	Fan motor output	Motor output of BLDC
CN_WF	Wi-Fi module	Wi-Fi module connection
CN-PTC	Auxiliary heater	Auxiliary heater connection
CN_DUST	N/A	N/A
CN_FLOAT	Float switch input	Float switch sensing
CN_EEV	EEV output	EEV control output
CN_DISPLAY	Display	Display of indoor status
CN_OPTION	Option PCB (EEPROM)	Option PCB connection
CN_ROOM	Room sensor	Room air thermistor
CN_PIPE_IN	Suction pipe sensor	Pipe in thermistor
CN_HUMID	N/A	N/A
CN_LEAK	Leak sensor	Leak sensor connection
CN_PIPE_OUT	Discharge pipe sensor	Pipe out thermistor
CN_EXT	External on/off controller	External on/off controller connection
CN_CC	Dry Contact	Connection to Dry Contact (Optional)
CN_AIRC	Air cleaner	Air cleaner control
CN_VANE2	Step Motor	Step motor output
CN_VANE1	Step Motor	Step motor output
CN_DCDRAIN	Drain pump output	AC output for drain pump
CN_485	Communication	Connection between indoor and outdoor units
CN_COMM	Communication	Connection on Sub PCB between indoor and outdoor units
CN_REMO	Remote controller	Remote control connection
CN_POWER	AC Power supply	AC power line input for indoor controller

Table 33: TR / TQ Frame DIP Switch Settings.

DIP Switch Setting		Off	On	Remarks
SW3	GROUP CONTROL	Master	Slave	Group control setting using 7-Day Programmable Controller; selects Master / Slave on each indoor unit
SW4	DRY CONTACT MODE	Variable	Auto	Sets operation mode for optional Dry Contact accessory 1. Variable: Auto or Manual Mode can be set through 7-Day Programmable Controller or Wireless Remote Controller (factory default setting is Auto if there is no setting) 2. Auto: For Dry Contact, it is always Auto mode
SW7	VENTILATOR INTERLOCK	Off	On	Selects ventilator interlock function for four-way ceiling cassette indoor units. 1. On: Automatic (vent relay will be turned on after ten [10] seconds of indoor unit operation) 2. Off: Manual (ventilator needs to be set through the controller)

**\*For Gen 4 Multi V four-way ceiling cassette indoor units, DIP switches 1, 2, 5, 6, and 8 must be set to OFF. These DIP switches are used for other models.**

**\*\*To enable Generation 4 features, outdoor unit DIP switch no. 3 must be set to ON. Please refer to the Multi V 5, Multi V IV, Multi V Water IV, Multi V S Engineering Manual for additional information.**

# FOUR-WAY CEILING CASSETTE

## Electrical Wiring Diagram TN and TM Frames

Figure 35: ARNU073TNA4, ARNU093TNA4, ARNU123TNA4, ARNU153TNA4, ARNU183TNA4, ARNU243TNA4, ARNU283TMA4, ARNU363TMA4, ARNU423TMC4, ARNU483TMC4 Wiring Diagram.

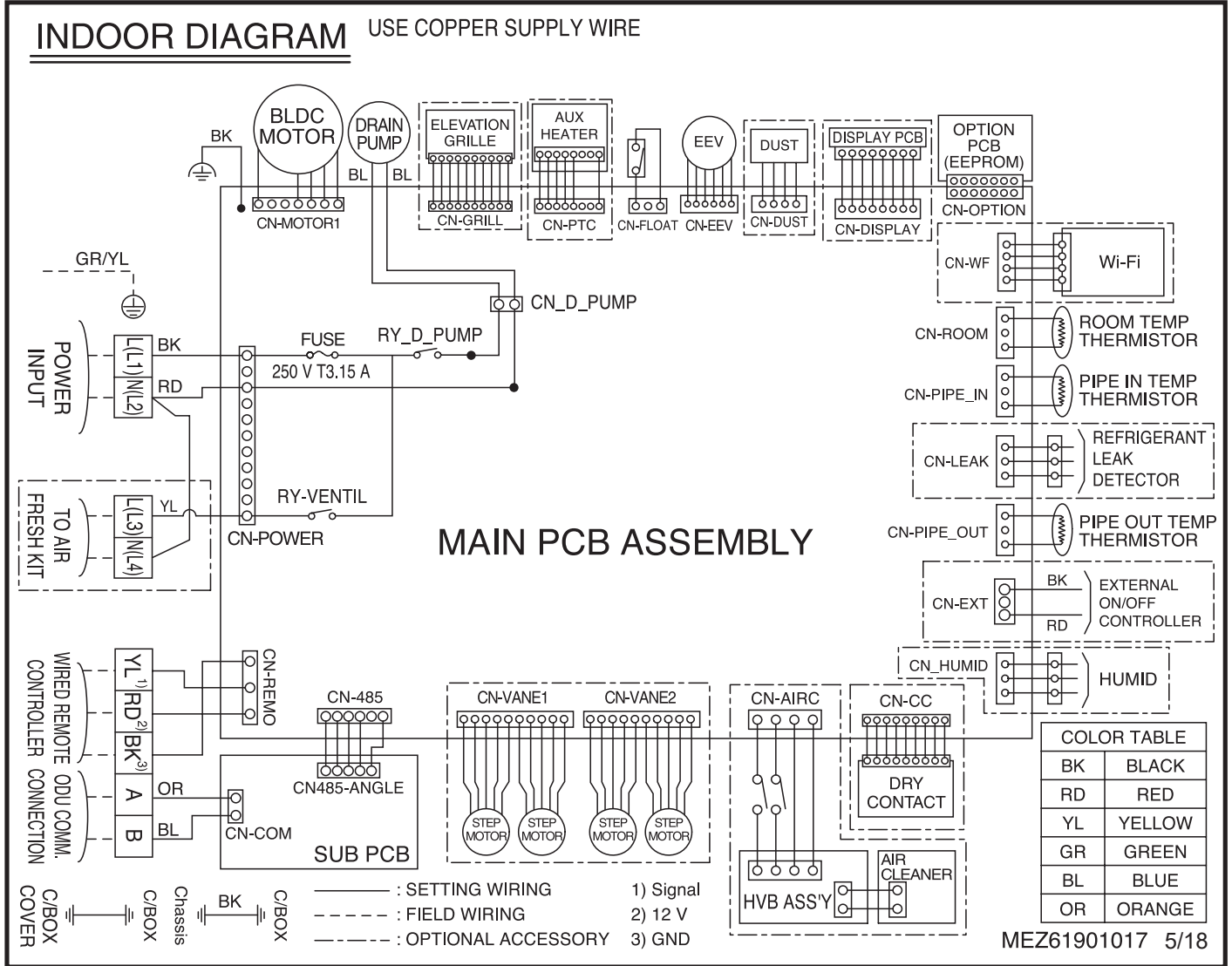



Table 34: TN, and TM Frame Wiring Diagram Legend.

Terminal	Purpose	Function
CN-MOTOR1	Fan motor output	Motor output of BLDC
CN-D_PUMP	Drain pump output	AC output for drain pump
CN-GRILL	Elevation grille	Elevation grille connection
CN-PTC	Auxiliary heater	Auxiliary heater connection
CN-FLOAT	Float switch input	Float switch sensing
CN-EEV	EEV Output	EEV control output
CN-DUST	N/A	N/A
CN-DISPLAY	Display	Display of indoor status
CN-OPTION	Optional PCB EEPROM	Option PCB connection
CN-WF	Wi-Fi module	Wi-Fi module connection
CN-ROOM	Room sensor	Room air thermistor
CN-PIPE_IN	Suction pipe sensor	Pipe in thermistor
CN_LEAK	Leak sensor	Leak sensor connection
CN-PIPE_OUT	Discharge pipe sensor	Pipe out thermistor
CN-EXT	External on/off controller	External on/off controller connection
CN-HUMID	N/A	N/A
CN-CC	Dry contact	Dry Contact connection
CN-AIRC	Air cleaner	Air cleaner control
CN-VANE2	Step motor	Step motor output
CN-VANE1	Step motor	Step motor output
CN-485	Communication	Connection between indoor and outdoor units
CN-COM	Communication	Connection on Sub PCB between indoor and outdoor units
CN-REMO	Wired remote controller	Wired remote control connection
CN-POWER	AC Power supply	AC Power line

Table 35: TN, and TM Frame DIP Switch Settings.

DIP Switch Setting		Off	On	Remarks
SW3	GROUP CONTROL	Master	Slave	Group control setting using 7-Day Programmable Controller; selects Master / Slave on each indoor unit
SW4	DRY CONTACT MODE	Variable	Auto	Sets operation mode for optional Dry Contact accessory 1. Variable: Auto or Manual Mode can be set through 7-Day Programmable Controller or Wireless Remote Controller (factory default setting is Auto if there is no setting) 2. Auto: For Dry Contact, it is always Auto mode
SW7	VENTILATOR INTERLOCK	Off	On	Selects ventilator interlock function for four-way ceiling cassette indoor units. 1. On: Automatic (vent relay will be turned on after ten [10] seconds of indoor unit operation) 2. Off: Manual (ventilator needs to be set through the controller)

**\*For Gen 4 Multi V four-way ceiling cassette indoor units, DIP switches 1, 2, 5, 6, and 8 must be set to OFF. These DIP switches are used for other models.**

**\*\*To enable Generation 4 features, outdoor unit DIP switch no. 3 must be set to ON. Please refer to the Multi V 5, Multi V IV, Multi V Water IV, Multi V S Engineering Manual for additional information.**

# FOUR-WAY CEILING CASSETTE

## Refrigerant Flow Diagram TR, TQ, TN, TM Frames

Figure 36: TR, TQ, TN, TM Frame Piping Diagram.

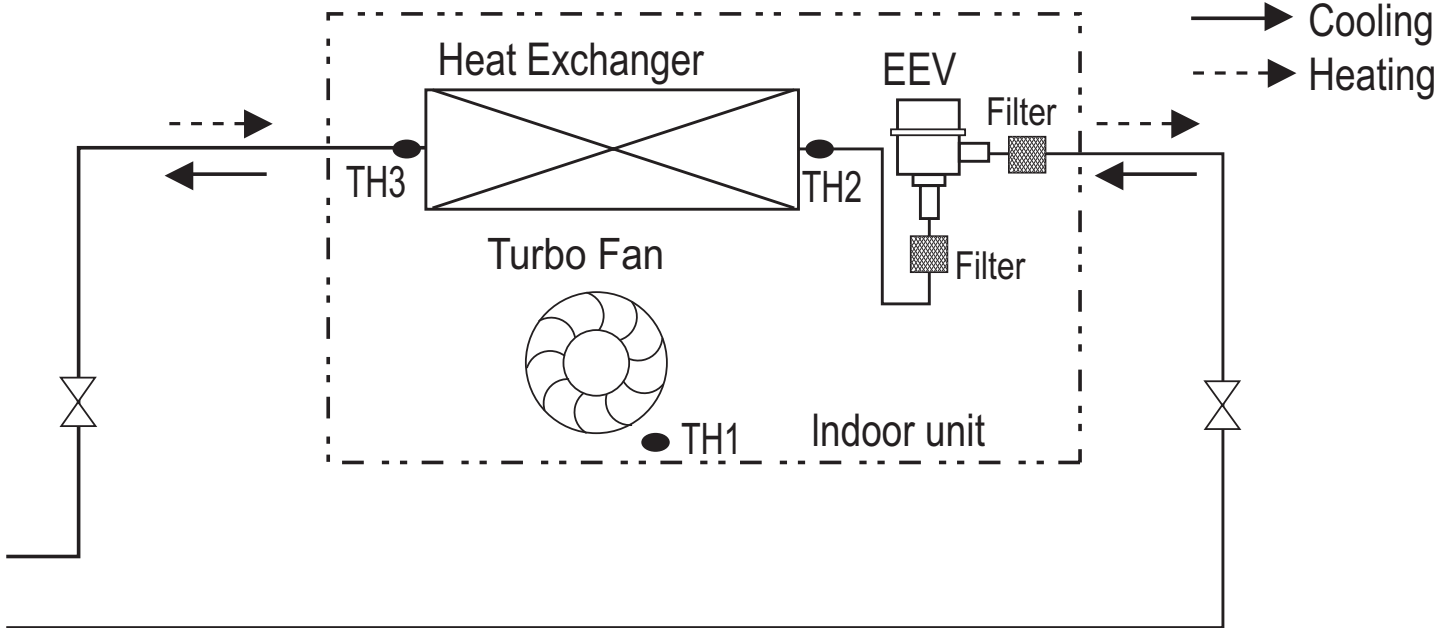

Table 36: TR, TQ, TN, TM Frame Refrigerant Pipe Connection Port Diameters.

Model	Liquid (inch)	Vapor (inch)
<b>2' x 2' Frames</b>		
ARNU053TRD4	1/4 Flare	1/2 Flare
ARNU073TRD4		
ARNU093TRD4		
ARNU123TRD4		
ARNU153TQD4		
ARNU183TQD4		
<b>3' x 3' Frames (TN, 9-11/16" High)</b>		
ARNU073TNA4	3/8 Flare	5/8 Flare
ARNU093TNA4		
ARNU123TNA4		
ARNU153TNA4		
ARNU183TNA4		
ARNU243TNA4		
<b>3' x 3' Frames (TM, 11-5/16" High)</b>		
ARNU283TMA4	3/8 Flare	5/8 Flare
ARNU363TMA4		
ARNU423TMC4		
ARNU483TMC4		

Table 37: TR, TQ, TN, TM Frame Thermistors.

Thermistor	Description
TH1	Return air thermistor
TH2	Pipe in thermistor
TH3	Pipe out thermistor

Figure 37: Sound Pressure Measurement Location.

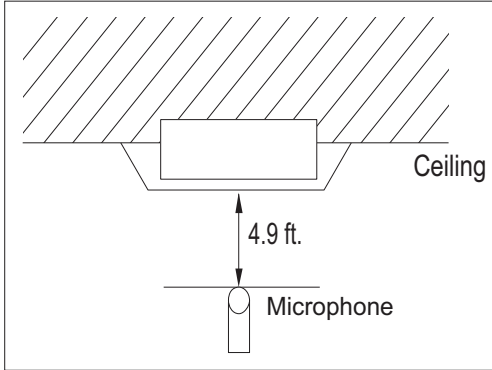

- Measurements are taken 4.9 ft away from the front of the unit.
  - Sound pressure levels are measured in dB(A) with a tolerance of  $\pm 3$ .
  - Sound pressure levels are tested in an anechoic chamber under ISO Standard 3745.
- Operating Conditions:
- Power source: 220V/60 Hz
  - Sound level will vary depending on a range of factors including the construction (acoustic absorption coefficient) of a particular room in which the unit was installed.

Table 38: Four-Way Ceiling Cassette Indoor Unit Sound Pressure Levels.

Model	Sound Pressure Levels dB(A)		
	High Fan Speed	Medium Fan Speed	Low Fan Speed
<b>2' x 2' Frames</b>			
ARNU053TRD4	29.0	27.0	26.0
ARNU073TRD4	29.0	27.0	26.0
ARNU093TRD4	30.0	29.0	27.0
ARNU123TRD4	32.0	30.0	27.0
ARNU153TQD4	36.0	34.0	32.0
ARNU183TQD4	37.0	35.0	34.0
<b>3' x 3' Frames (TN, 9-11/16" High)</b>			
ARNU073TNA4	29.0	26.0	24.0
ARNU093TNA4	29.0	26.0	24.0
ARNU123TNA4	31.0	29.0	26.0
ARNU153TNA4	32.0	29.0	26.0
ARNU183TNA4	34.0	30.0	26.0
ARNU243TNA4	40.0	38.0	35.0
<b>3' x 3' Frames (TM, 11-5/16" High)</b>			
ARNU283TMA4	41.0	39.0	35.0
ARNU363TMA4	44.0	41.0	37.0
ARNU423TMC4	45.0	41.0	38.0
ARNU483TMC4	46.0	42.0	40.0

# FOUR-WAY CEILING CASSETTE



## Acoustic Data

### Sound Pressure Levels

Figure 38: ARNU053TRD4, ARNU073TRD4, and ARNU093TRD4 Sound Pressure Level Diagrams.

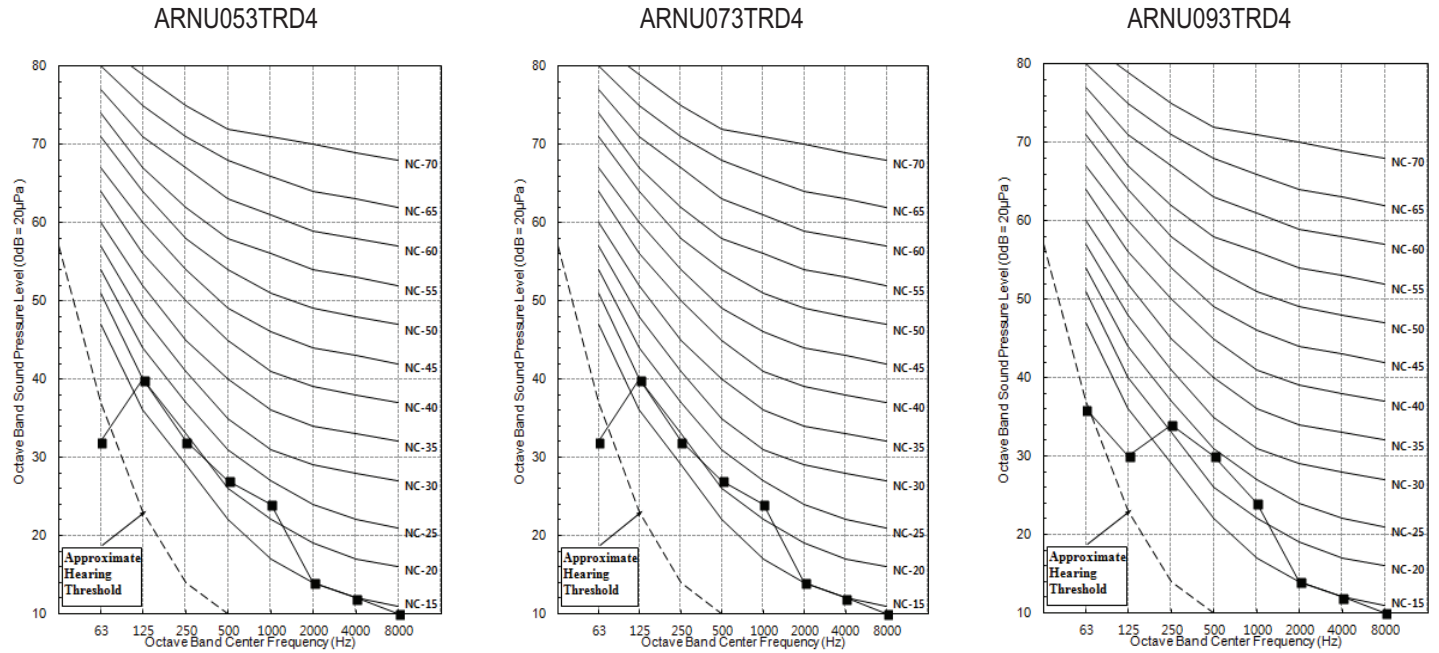

Figure 39: ARNU123TRD4, ARNU153TQD4, and ARNU183TQD4 Sound Pressure Level Diagrams.

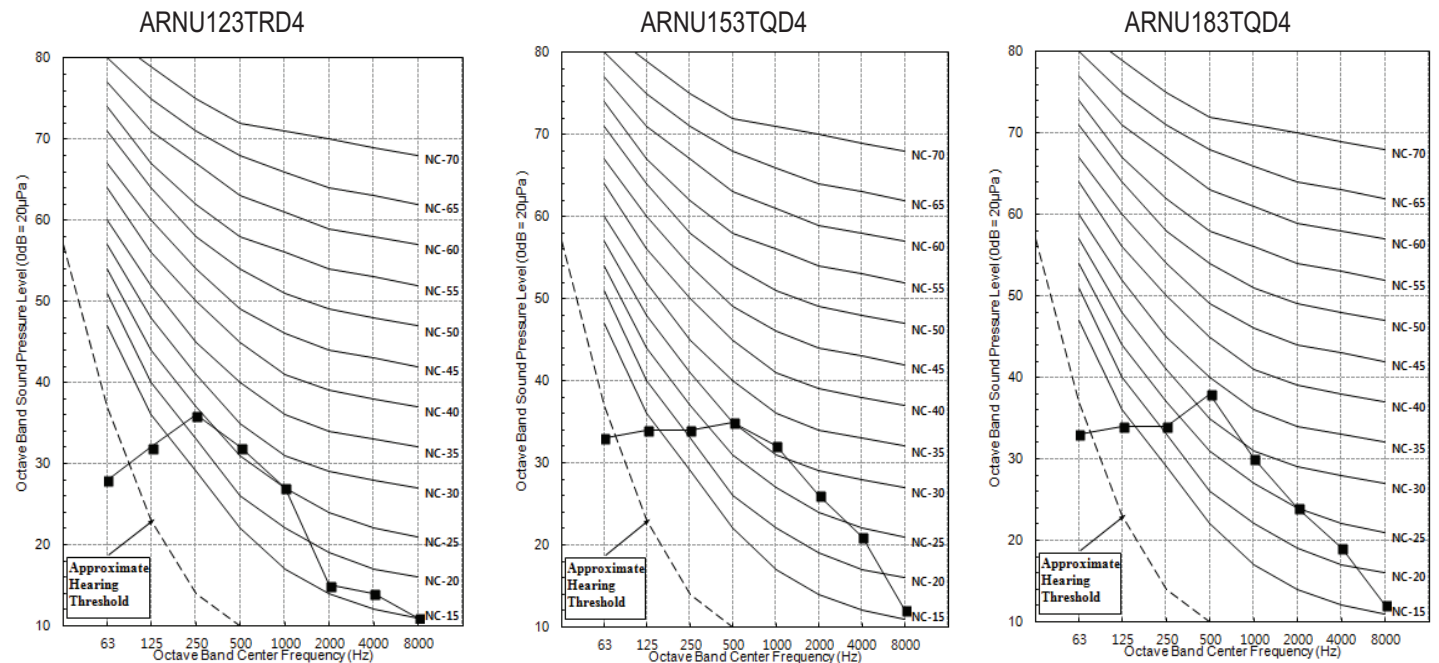
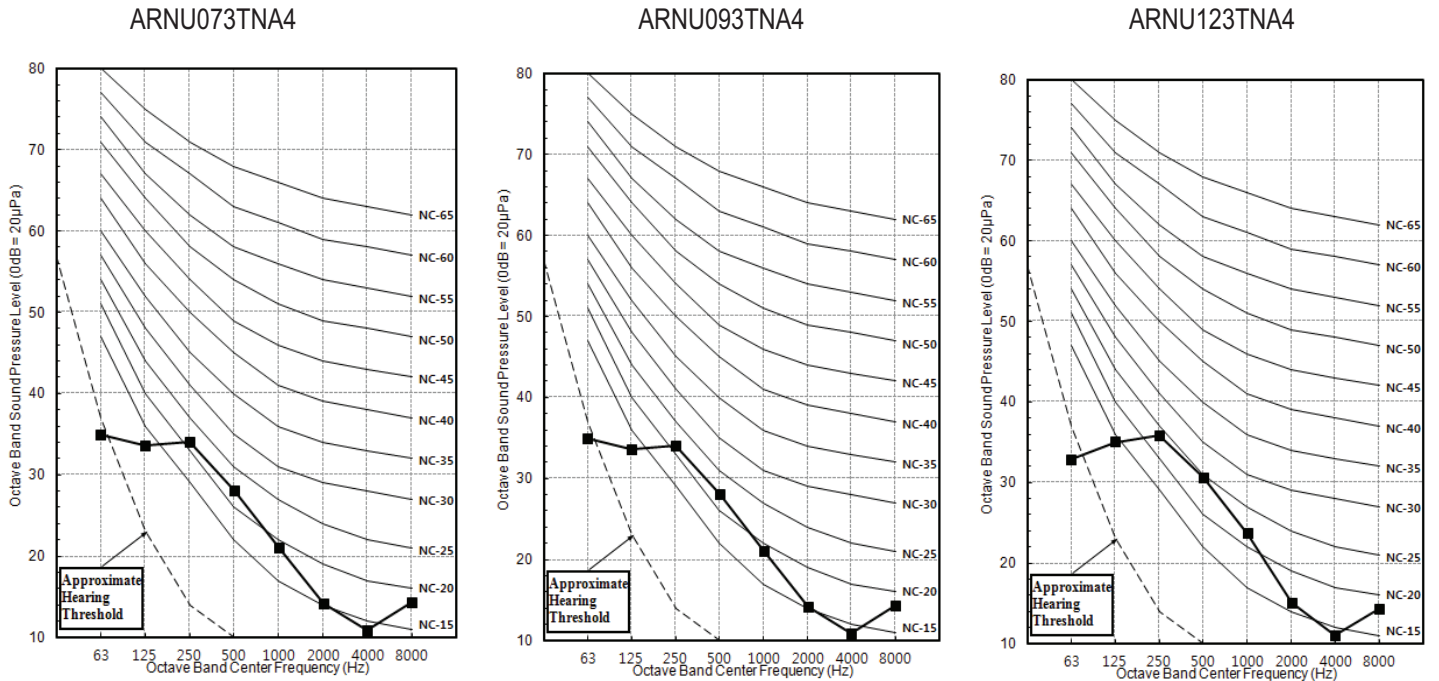

Figure 40: ARNU073TNA4, ARNU093TNA4, and ARNU123TNA4 Sound Pressure Level Diagrams.



# FOUR-WAY CEILING CASSETTE



## Acoustic Data

### Sound Pressure Levels

Figure 41: ARNU153TNA4, ARNU183TNA4, and ARNU243TNA4 Sound Pressure Level Diagrams.

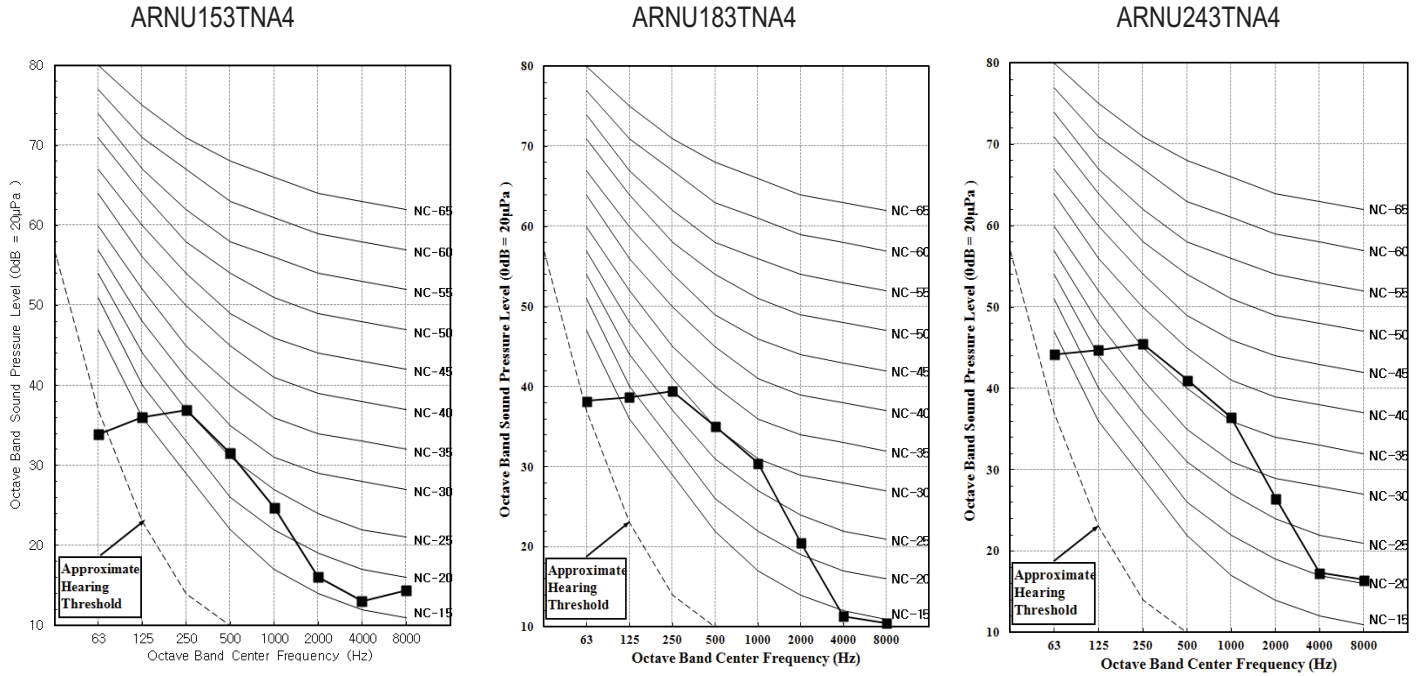

Figure 42: ARNU283TMA4 Sound Pressure Level Diagram.

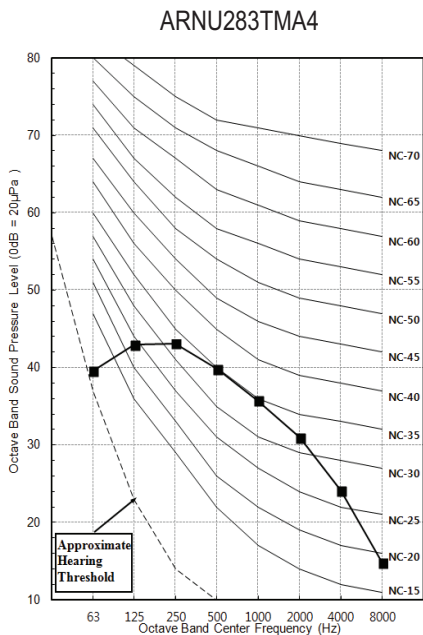
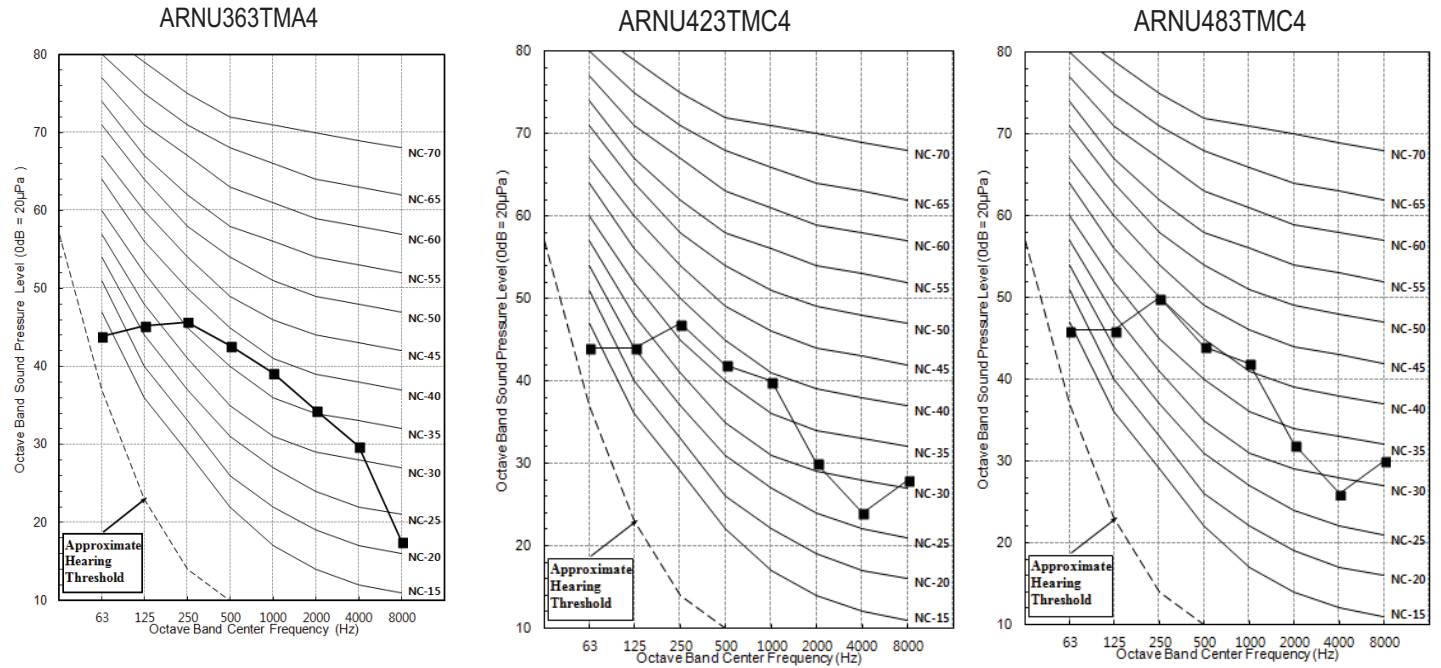

Figure 43: ARNU363TMA4, ARNU423TMCA, and ARNU483TMCA Sound Pressure Level Diagrams.



# FOUR-WAY CEILING CASSETTE



## Acoustic Data

### Sound Power Levels

Table 39: Four-Way Ceiling Cassette Indoor Unit Sound Power Levels.

Model	Sound Power Levels dB(A)
	High Fan Speed
<b>2' x 2' Frames</b>	
ARNU053TRD4	46.0
ARNU073TRD4	46.0
ARNU093TRD4	47.0
ARNU123TRD4	48.0
ARNU153TQD4	51.0
ARNU183TQD4	52.0
<b>3' x 3' Frames (TN, 9-11/16" High)</b>	
ARNU073TNA4	44.0
ARNU093TNA4	44.0
ARNU123TNA4	46.0
ARNU153TNA4	47.0
ARNU183TNA4	48.0
ARNU243TNA4	58.0
<b>3' x 3' Frames (TM, 11-5/16" High)</b>	
ARNU283TMA4	56.0
ARNU363TMA4	63.0
ARNU423TMC4	63.0
ARNU483TMC4	65.0

- Data is valid under diffuse field conditions.
- Data is valid under nominal operating conditions.
- Sound power level is measured using rated conditions, and tested in a reverberation room per ISO 3741 standards.
- Sound level will vary depending on a range of factors such as construction (acoustic absorption coefficient) of particular area in which the equipment is installed.
- Reference acoustic intensity: 0dB = 10E-6μW/m<sup>2</sup>

Figure 44: ARNU053TRD4, ARNU073TRD4, and ARNU093TRD4 Sound Power Level Diagrams.

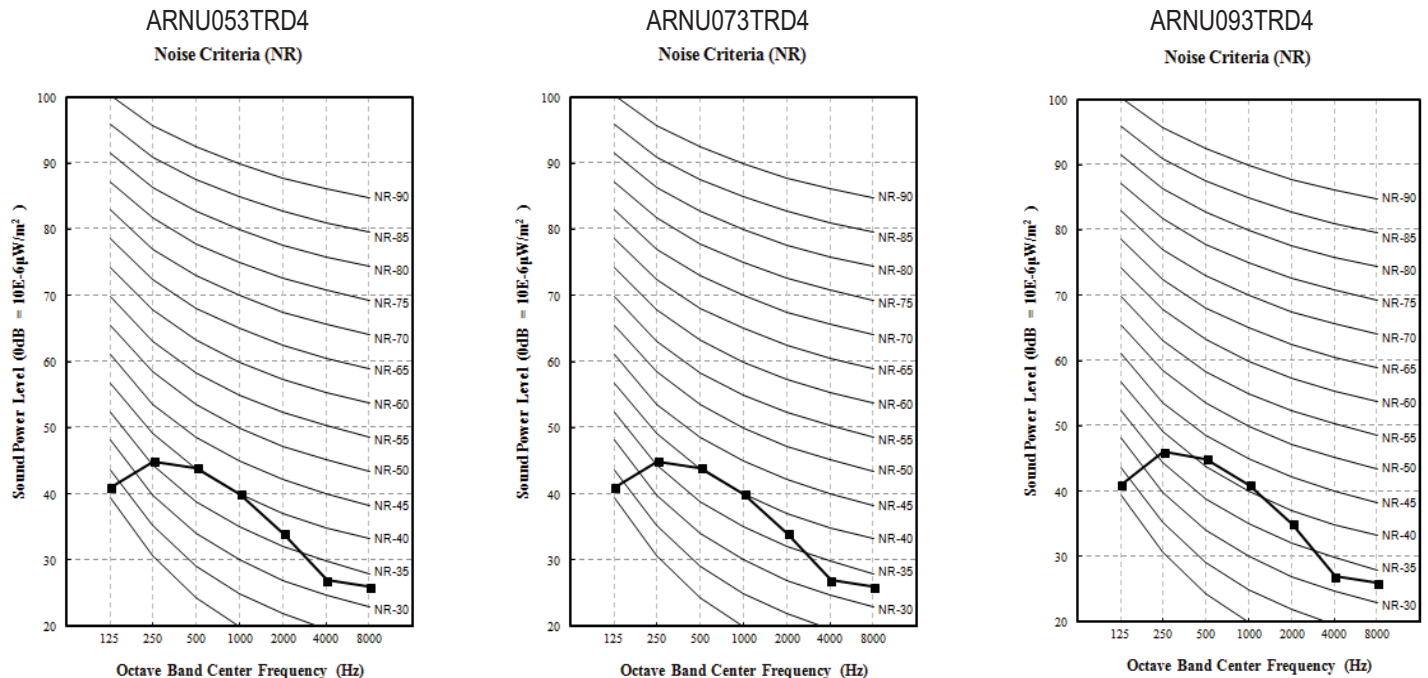
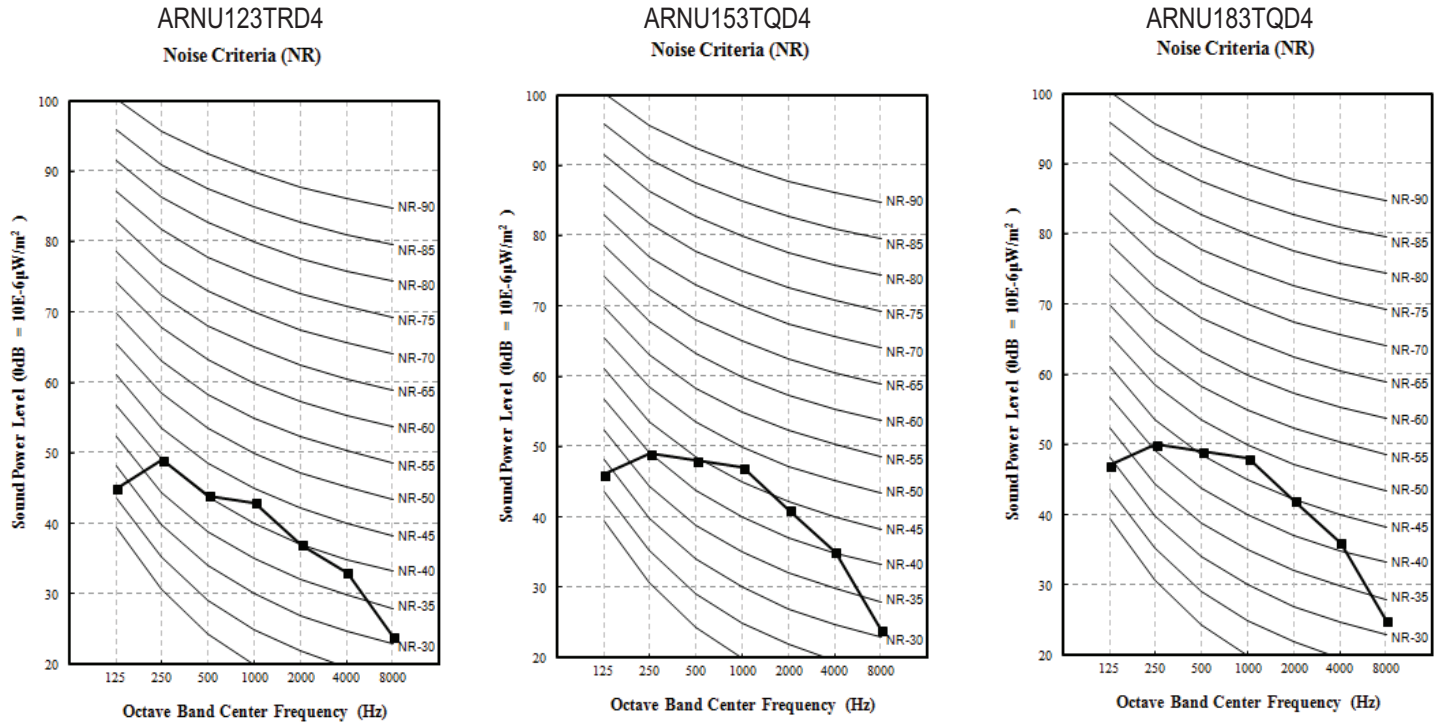



Figure 45: ARNU123TRD4, ARNU153TQD4, and ARNU183TQD4 Sound Power Level Diagrams.



# FOUR-WAY CEILING CASSETTE



## Acoustic Data

## Sound Power Levels

Figure 46: ARNU073TNA4, ARNU093TNA4, and ARNU123TNA4 Sound Power Level Diagrams.

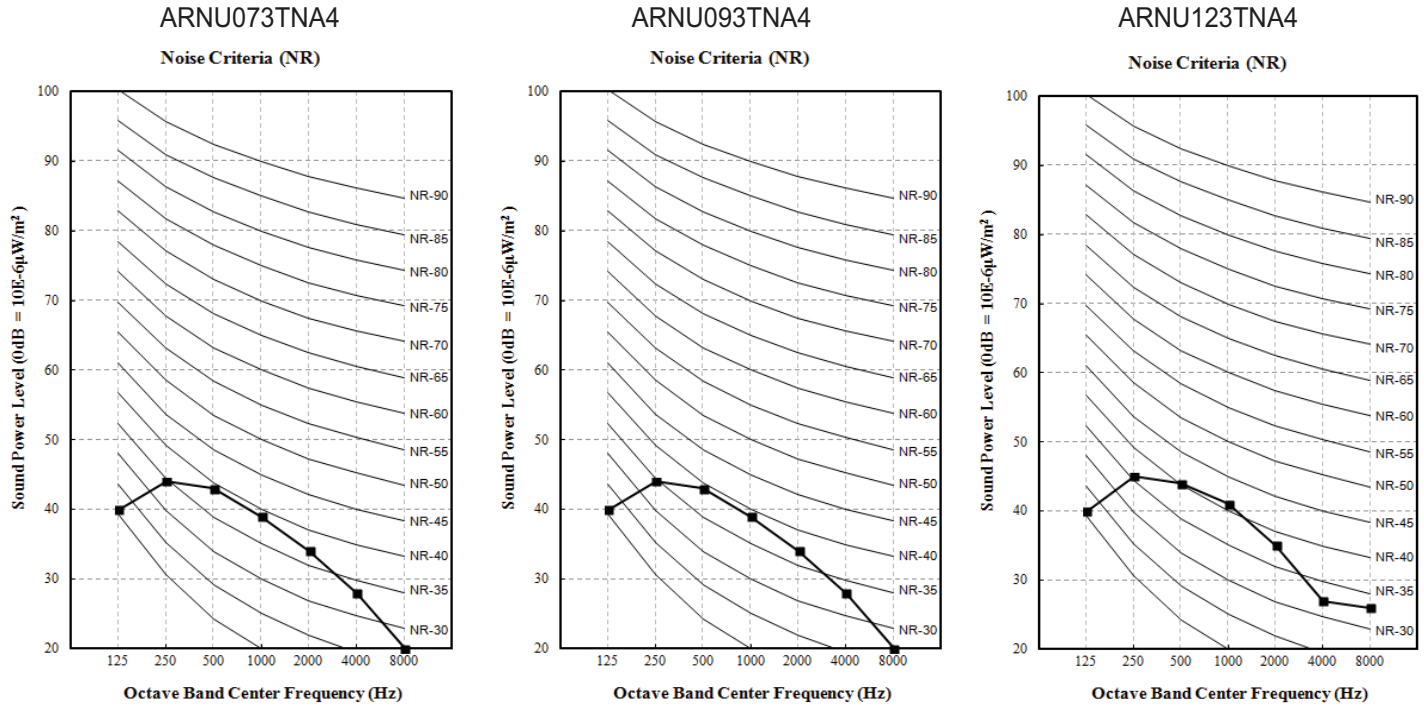

Figure 47: ARNU153TNA4, ARNU183TNA4, and ARNU243TNA4 Sound Power Level Diagrams.

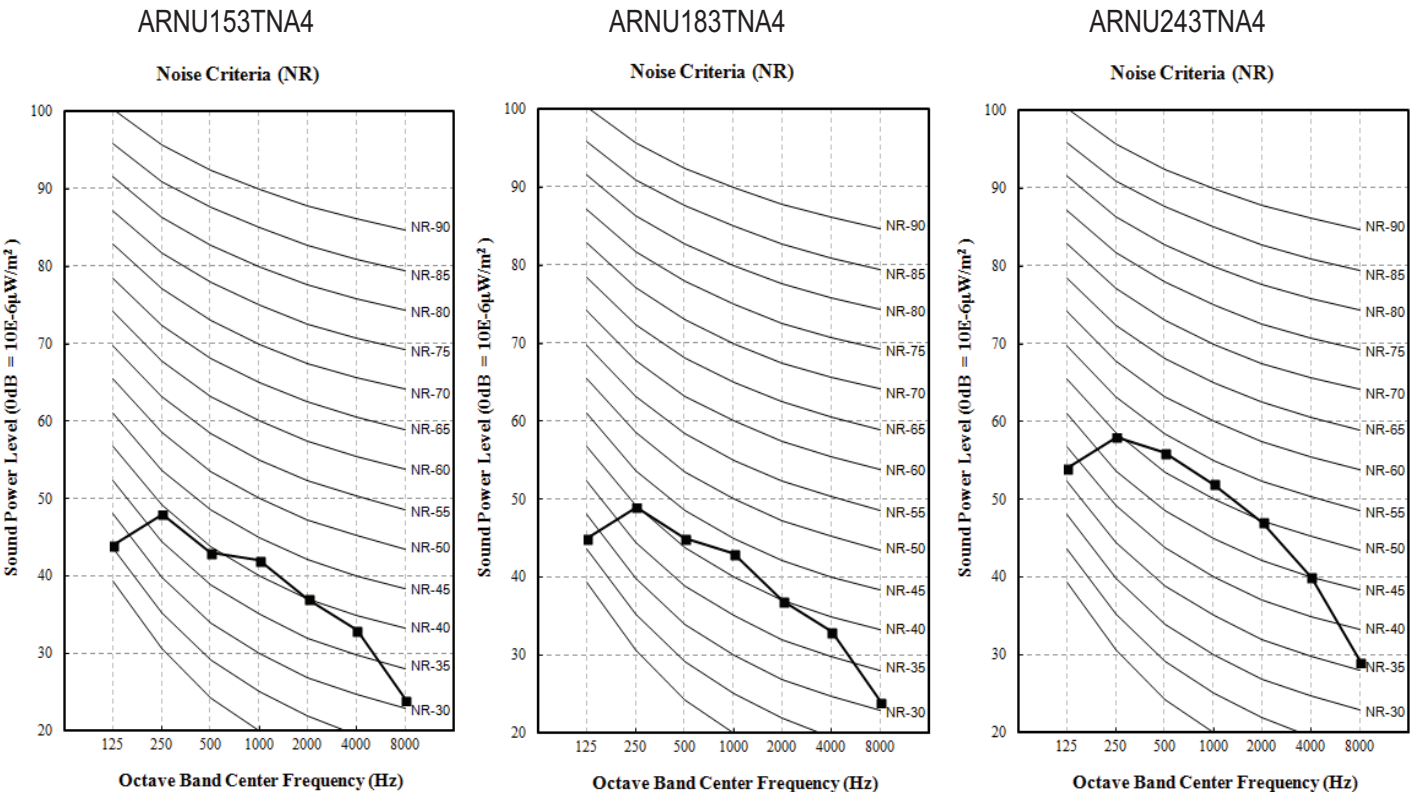

Figure 48: ARNU283TMA4 Sound Power Level Diagram.

**ARNU283TMA4**

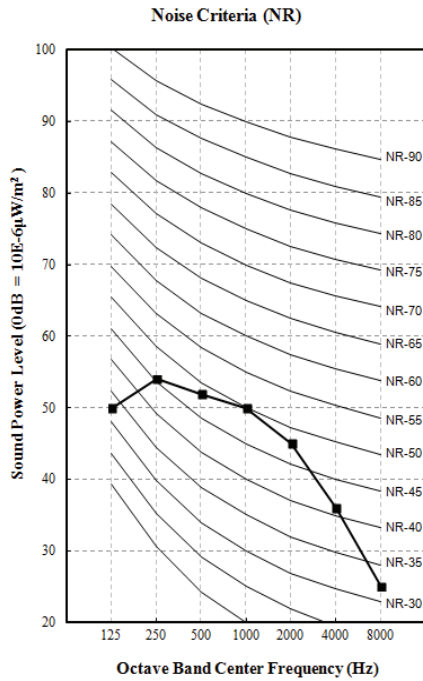

Figure 49: ARNU363TMA4 Sound Power Level Diagram.

**ARNU363TMA4**

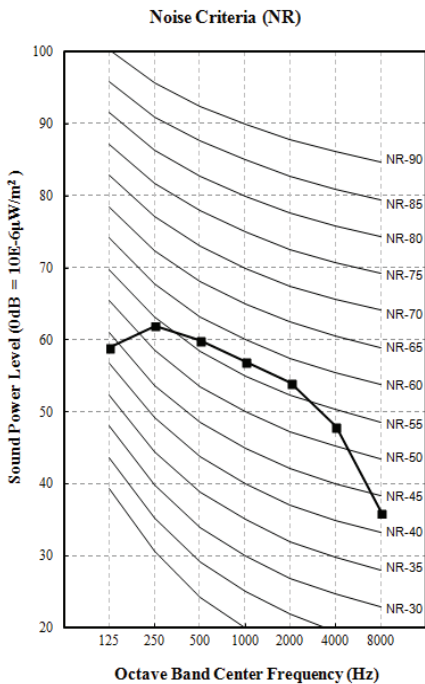
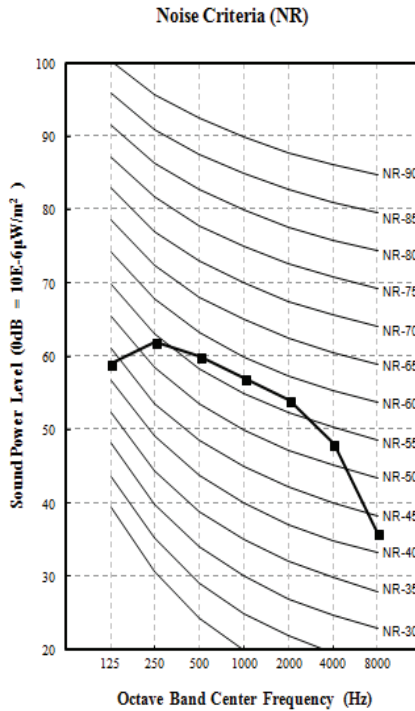
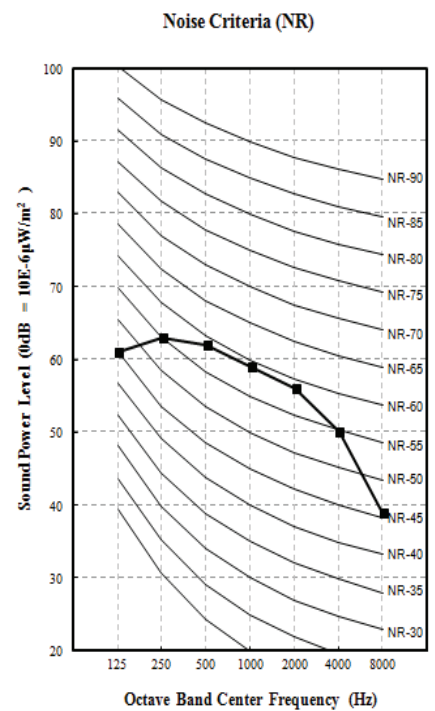

Figure 50: ARNU423TMC4 and ARNU483TMC4 Sound Power Level Diagrams.

**ARNU423TMC4**



**ARNU483TMC4**



# FOUR-WAY CEILING CASSETTE



## Air Velocity / Temperature Distribution

### ARNU053TRD4

Figure 51: ARNU053TRD4.

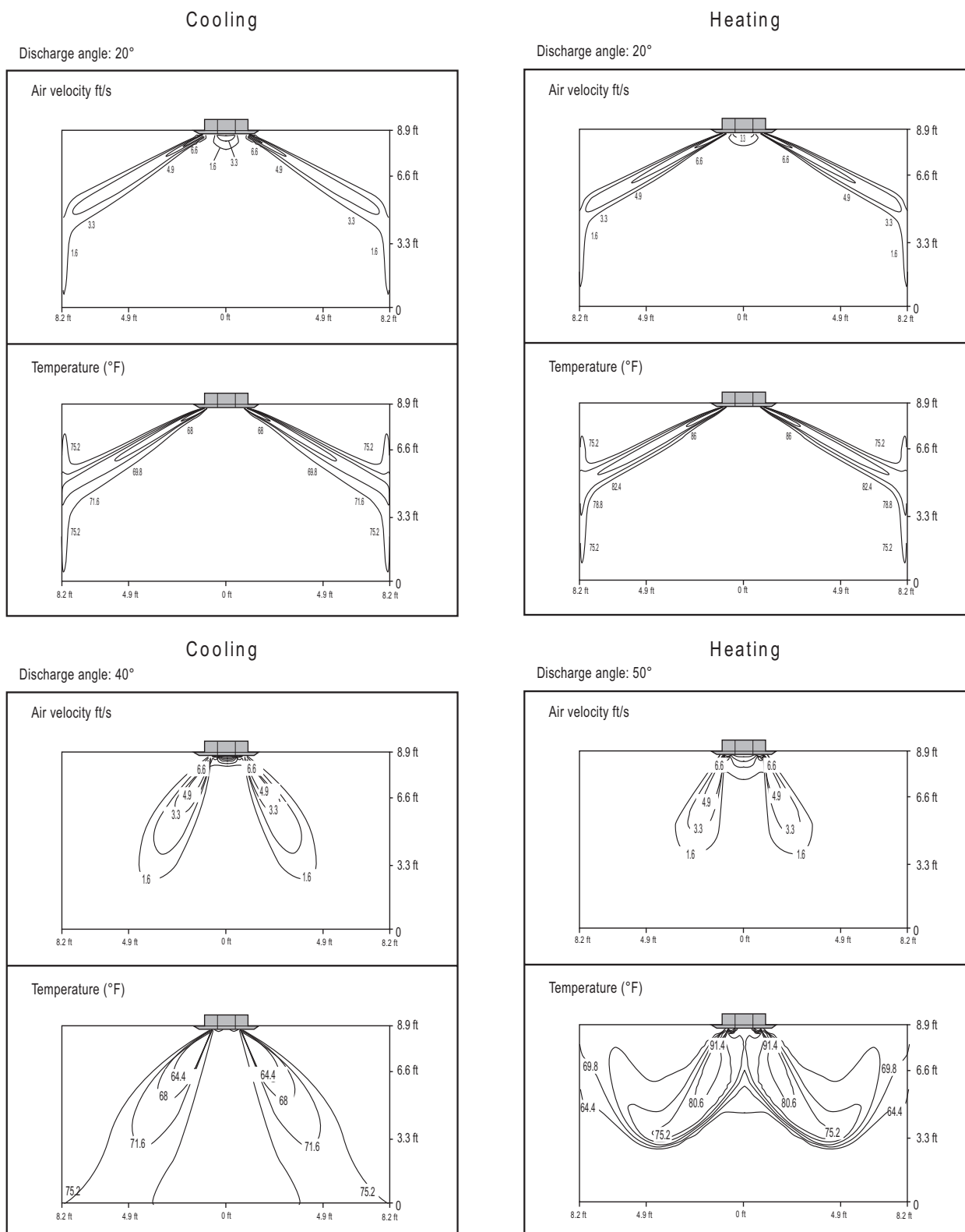

The standard setup height is 8.9 ft. The charts above show the measurement distribution at the ceiling height of 8.9 ft with a high fan operating mode.

Figure 52: ARNU053TRD4, continued.

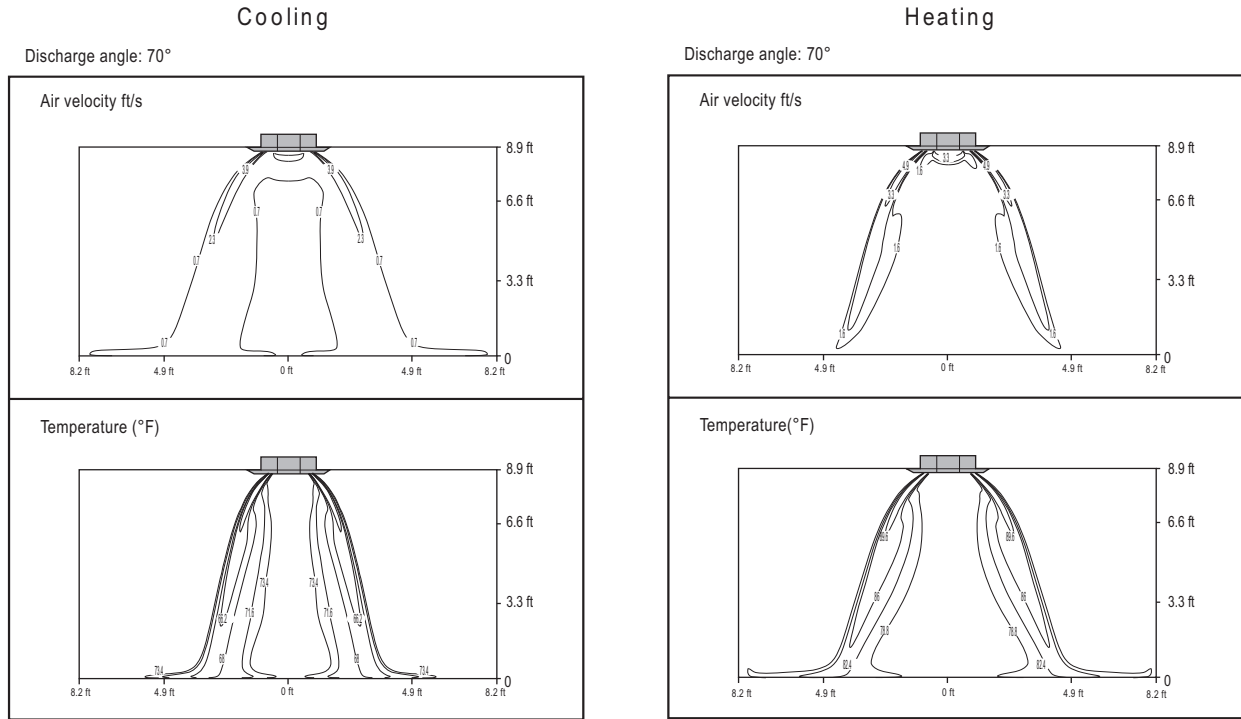
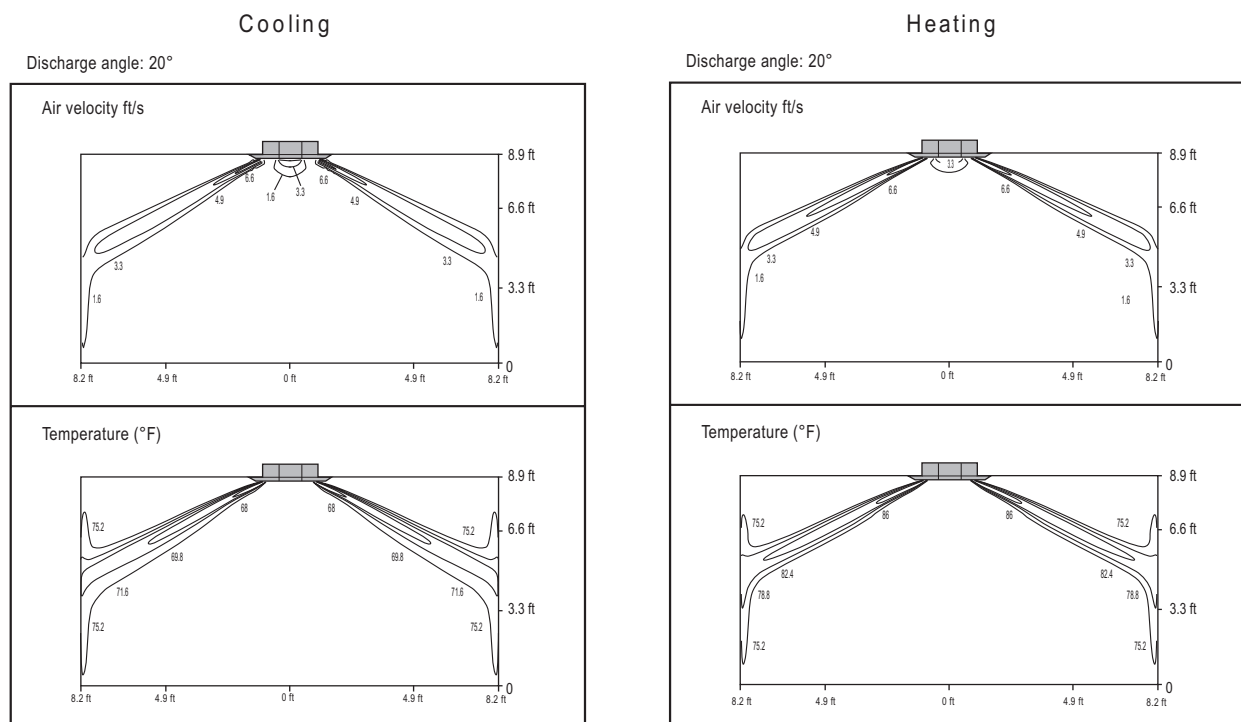

Figure 53: ARNU073TRD4.



The standard setup height is 8.9 ft. The charts above show the measurement distribution at the ceiling height of 8.9 ft with a high fan operating mode.

# FOUR-WAY CEILING CASSETTE



## Air Velocity / Temperature Distribution

### ARNU073TRD4

Figure 54: ARNU073TRD4, continued.

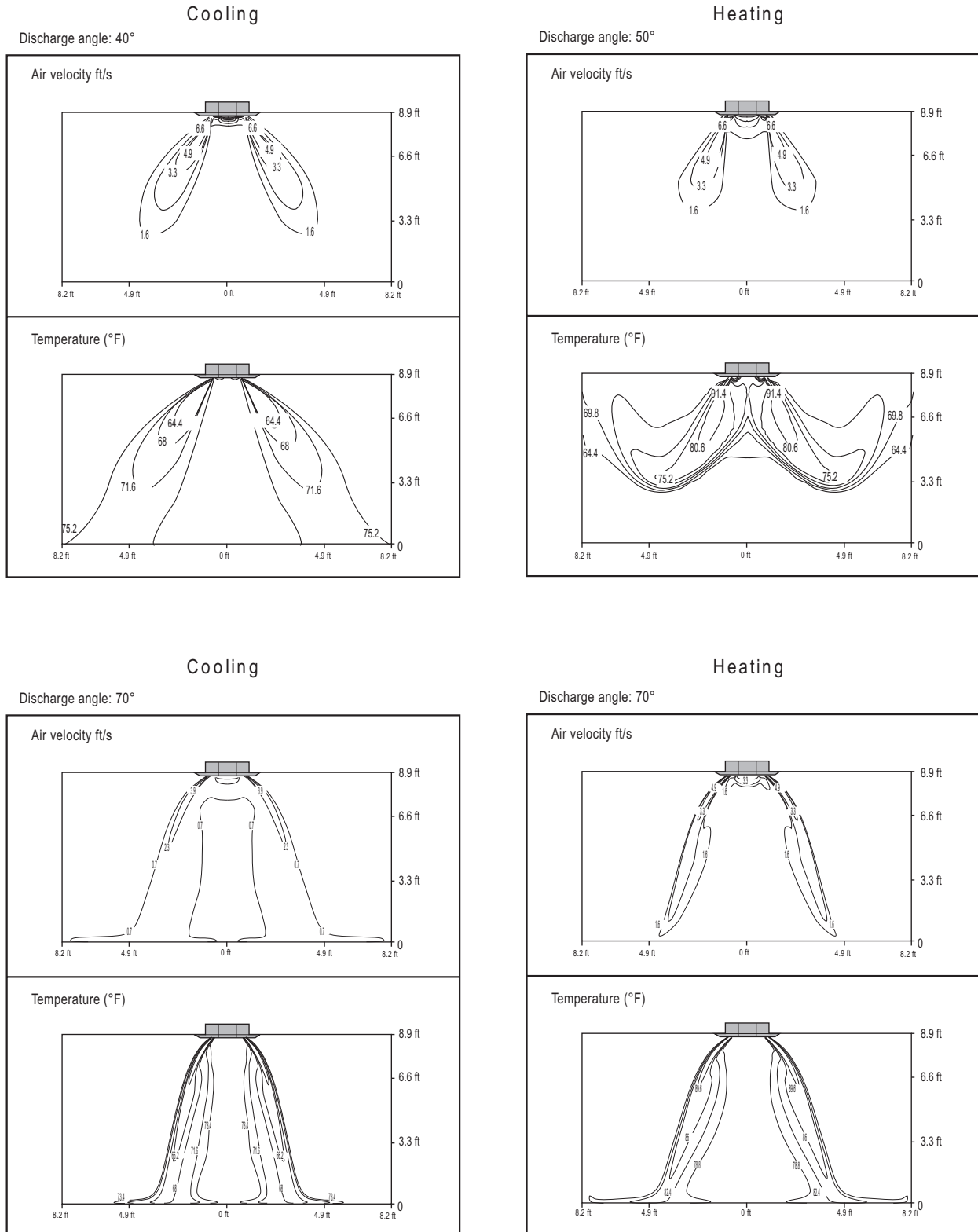

The standard setup height is 8.9 ft. The charts above show the measurement distribution at the ceiling height of 8.9 ft with a high fan operating mode.

Figure 55: ARNU093TRD4.

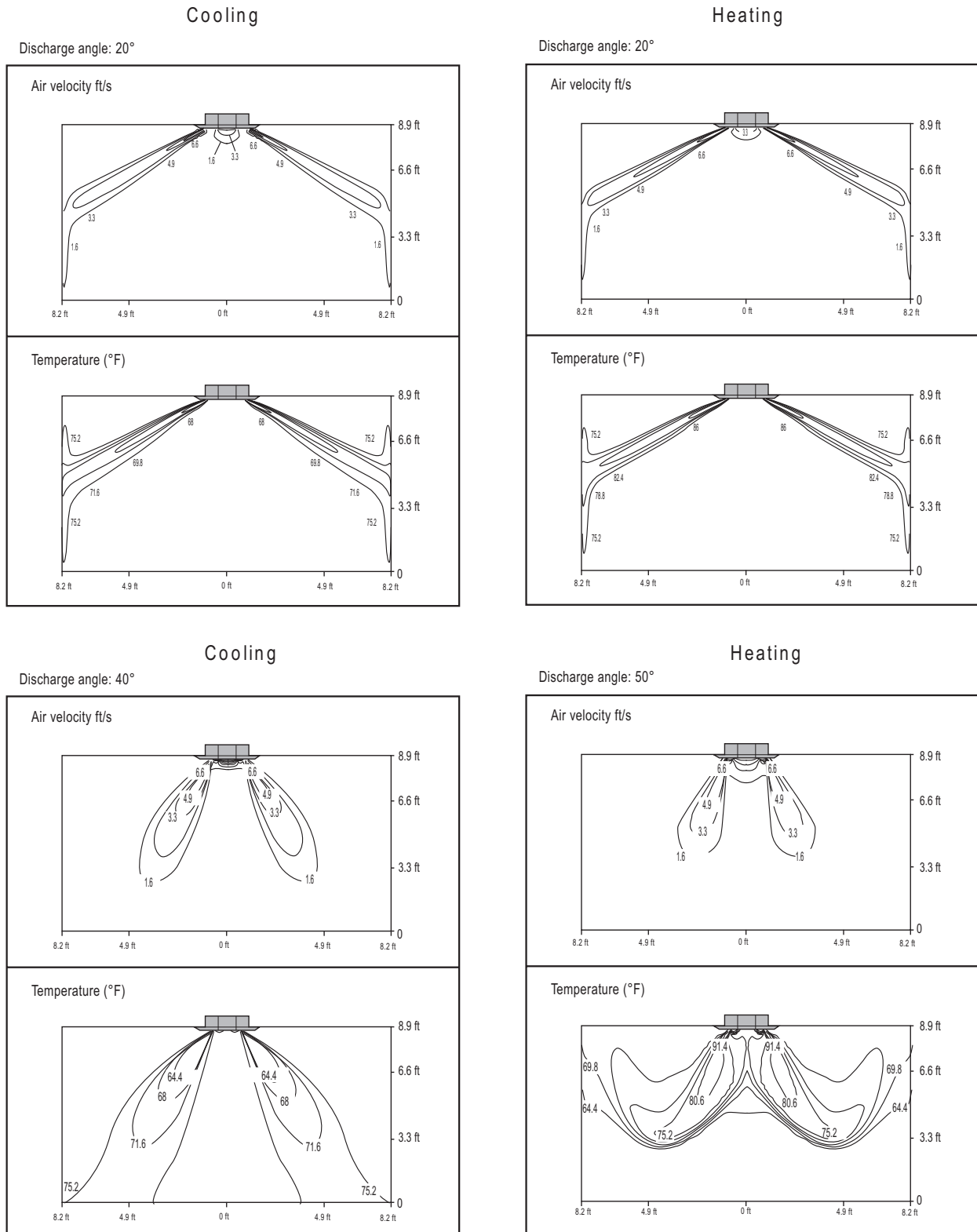

The standard setup height is 8.9 ft. The charts above show the measurement distribution at the ceiling height of 8.9 ft with a high fan operating mode.

# FOUR-WAY CEILING CASSETTE



## Air Velocity / Temperature Distribution ARNU093TRD4, ARNU123TRD4

Figure 56: ARNU093TRD4, continued.

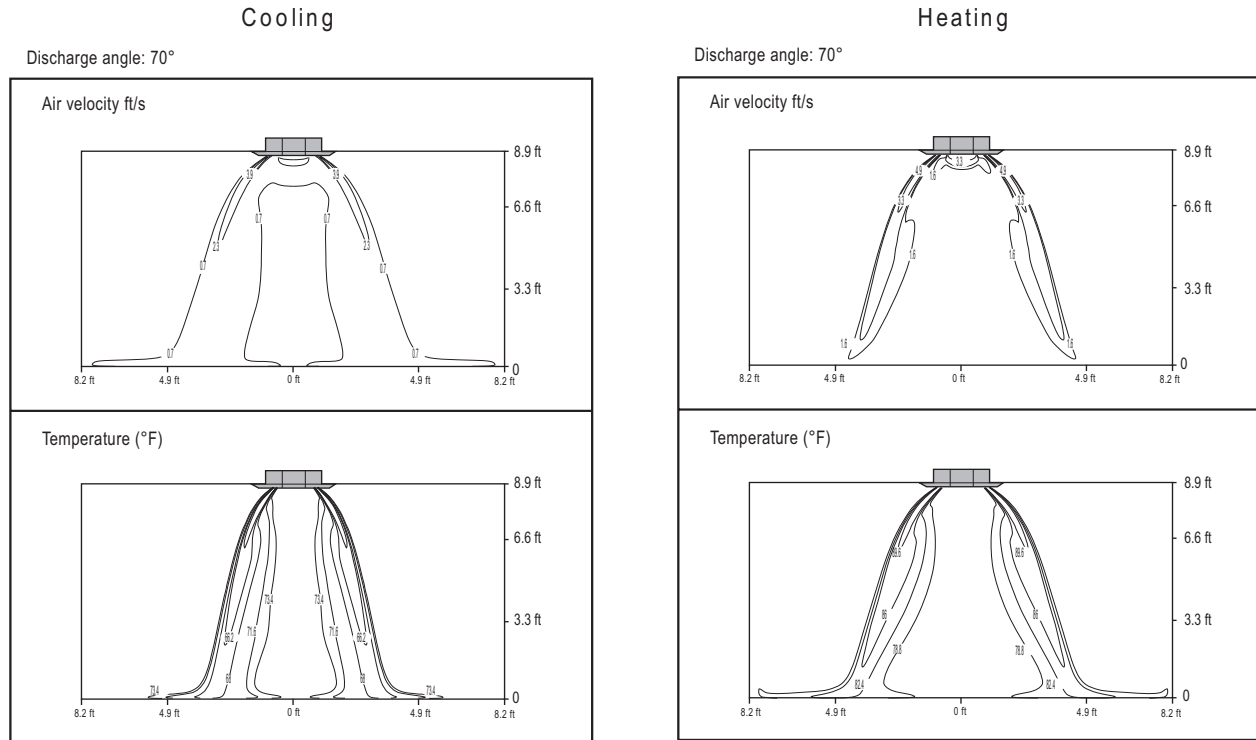
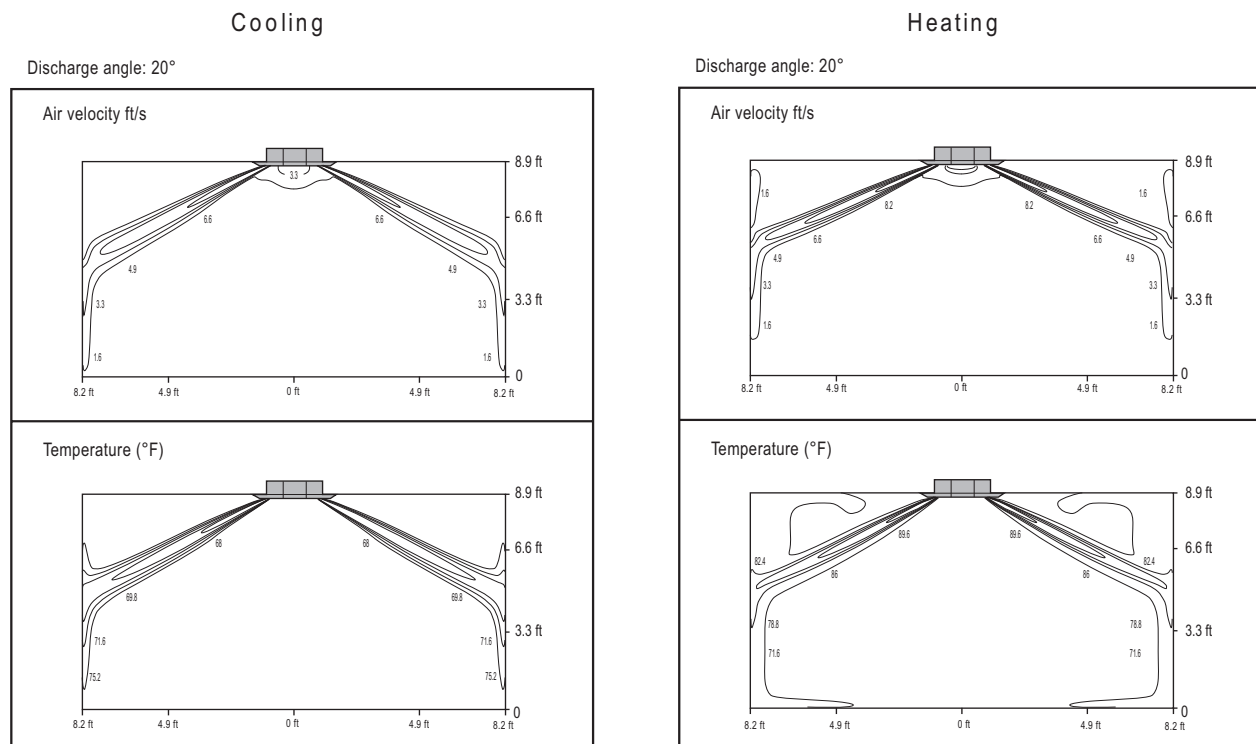

Figure 57: ARNU123TRD4.



The standard setup height is 8.9 ft. The charts above show the measurement distribution at the ceiling height of 8.9 ft with a high fan operating mode.



Figure 58: ARNU123TRD4, continued.

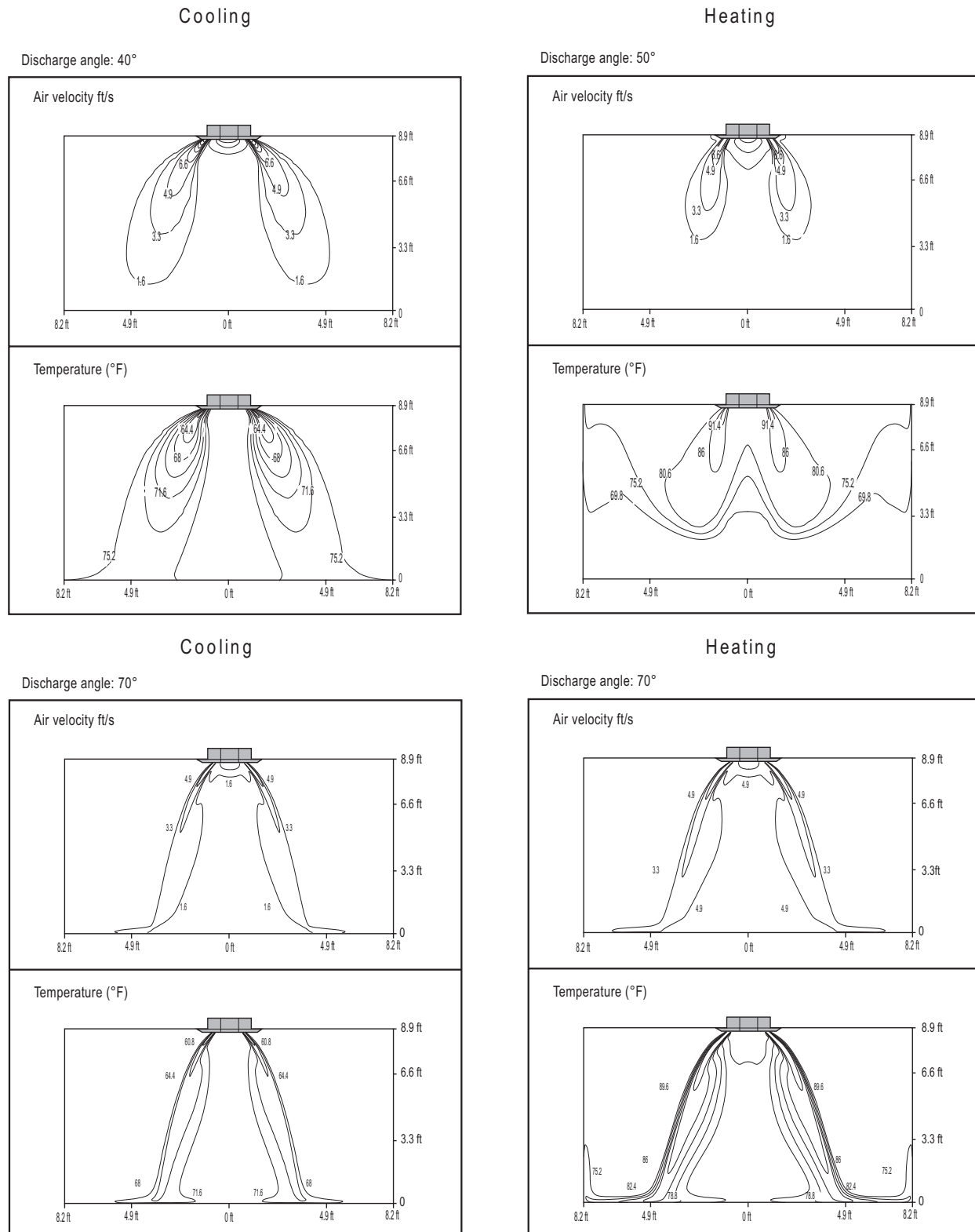

The standard setup height is 8.9 ft. The charts above show the measurement distribution at the ceiling height of 8.9 ft with a high fan operating mode.

# FOUR-WAY CEILING CASSETTE



## Air Velocity / Temperature Distribution ARNU153TQD4

Figure 59: ARNU153TQD4.

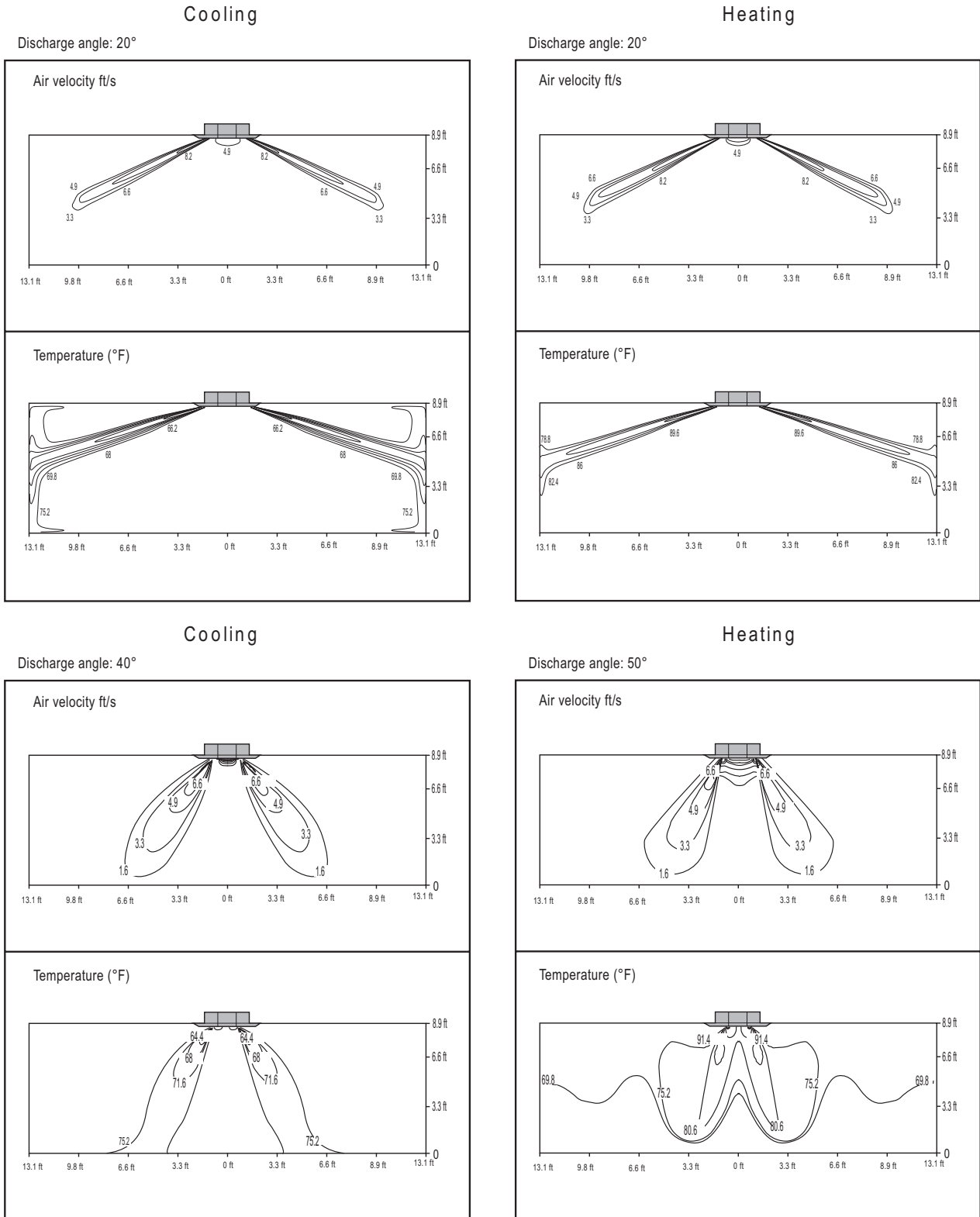

The standard setup height is 8.9 ft. The charts above show the measurement distribution at the ceiling height of 8.9 ft with a high fan operating mode.

Figure 60: ARNU153TQD4, continued.

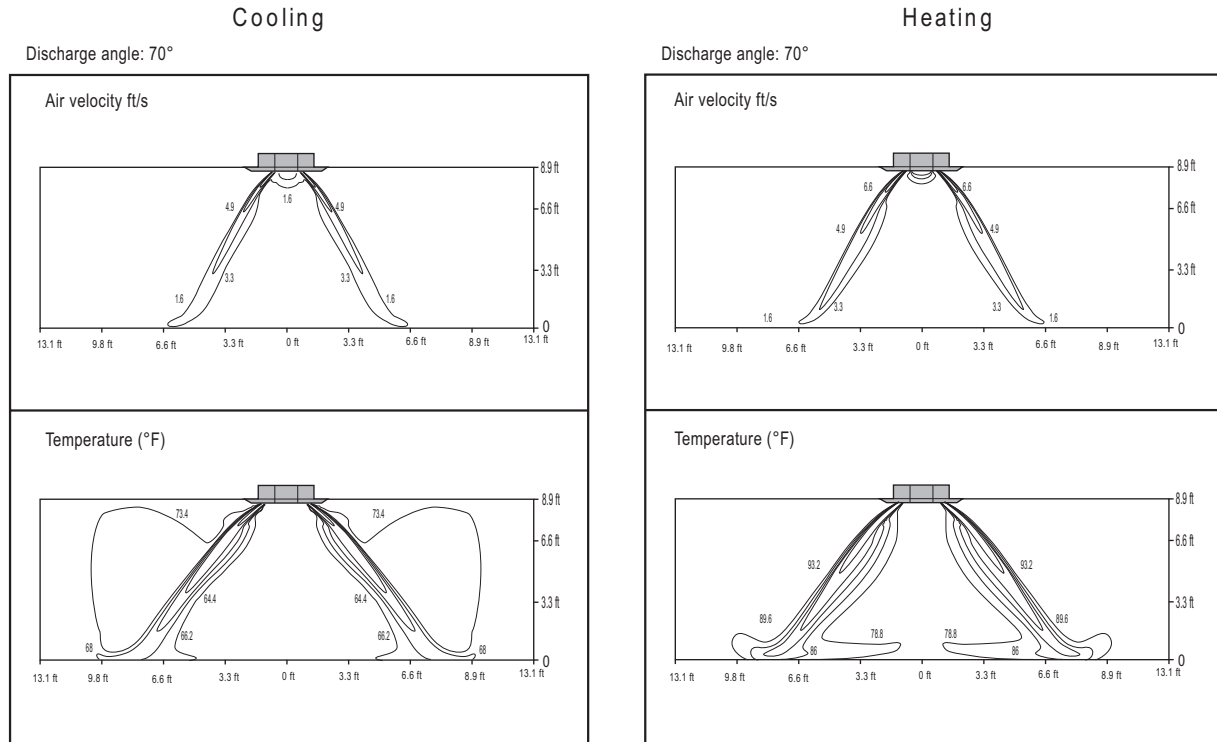
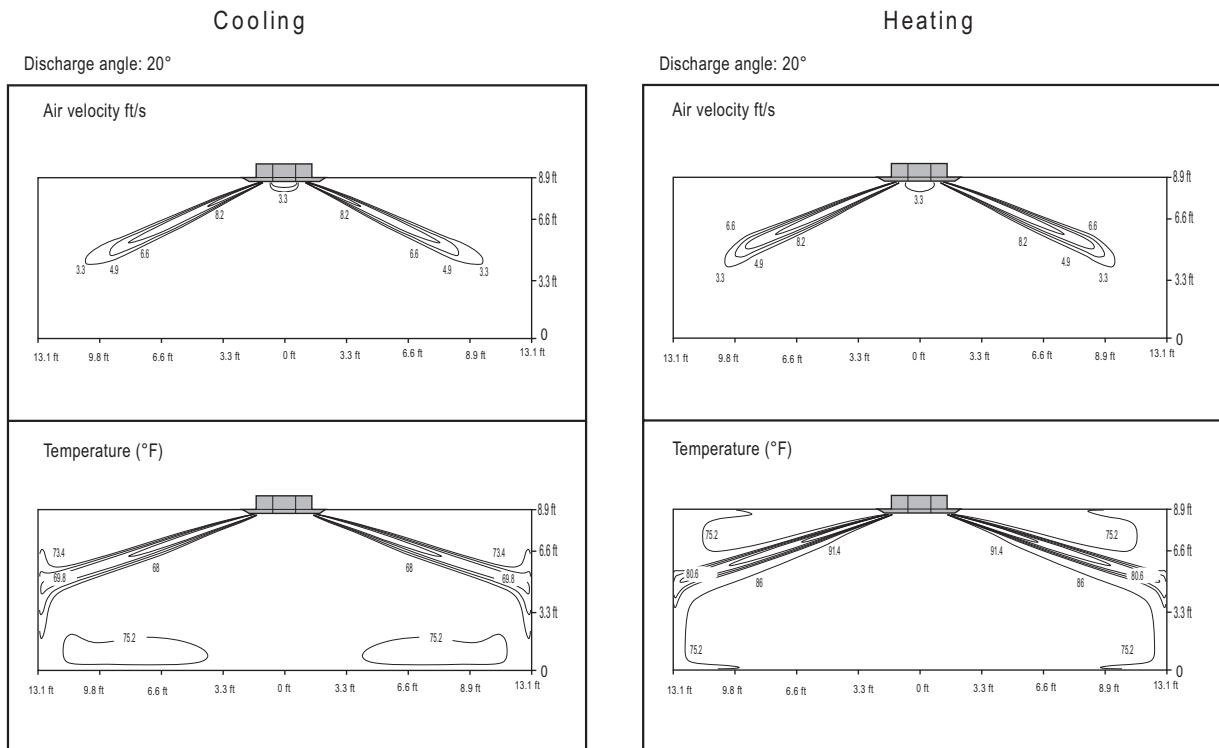

Figure 61: ARNU183TQD4.



The standard setup height is 8.9 ft. The charts above show the measurement distribution at the ceiling height of 8.9 ft with a high fan operating mode.

# FOUR-WAY CEILING CASSETTE



## Air Velocity / Temperature Distribution ARNU183TQD4

Figure 62: ARNU183TQD4, continued.

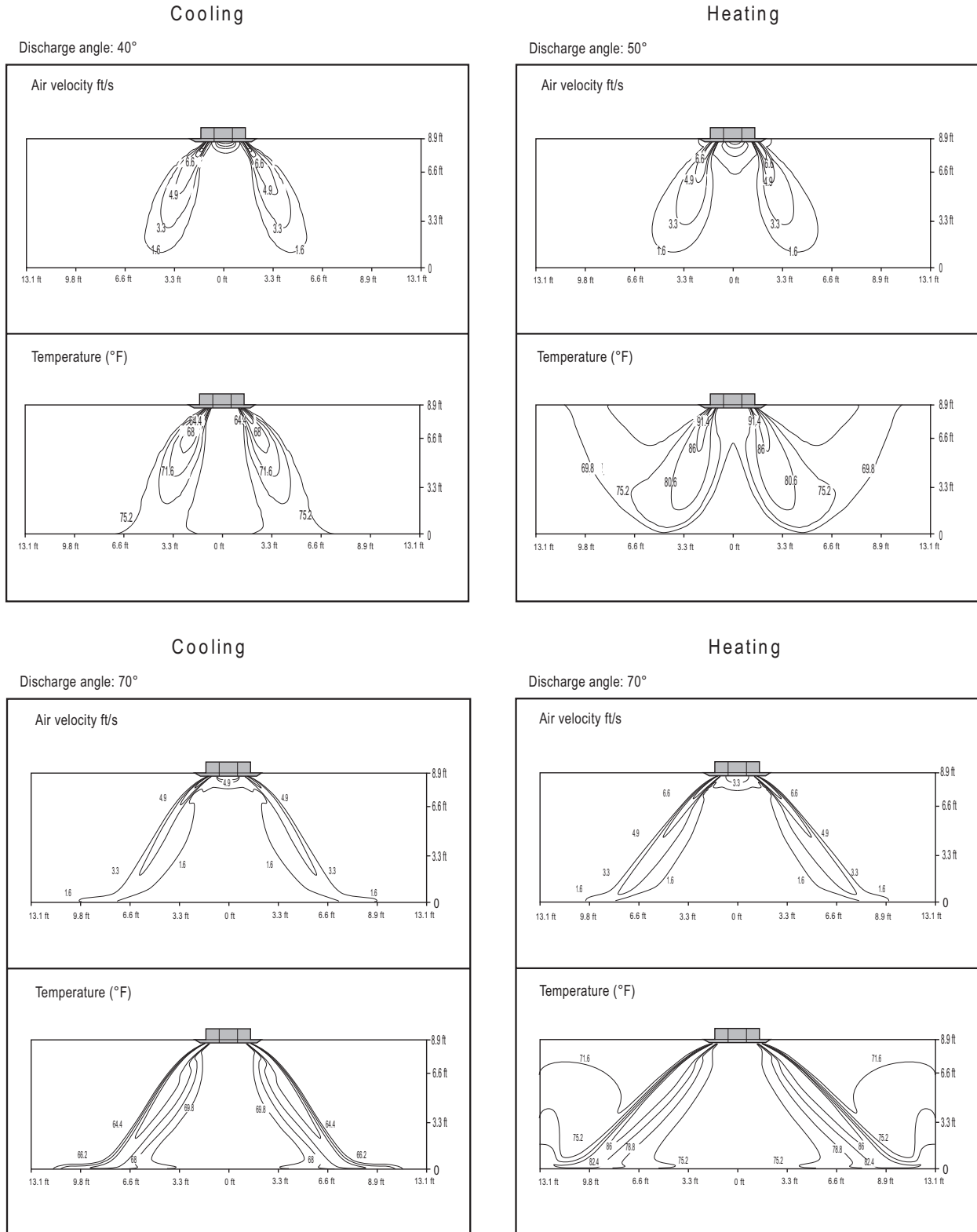

The standard setup height is 8.9 ft. The charts above show the measurement distribution at the ceiling height of 8.9 ft with a high fan operating mode.

Figure 63: ARNU073TNA4 and ARNU093TNA4.  
Discharge angle: 20°

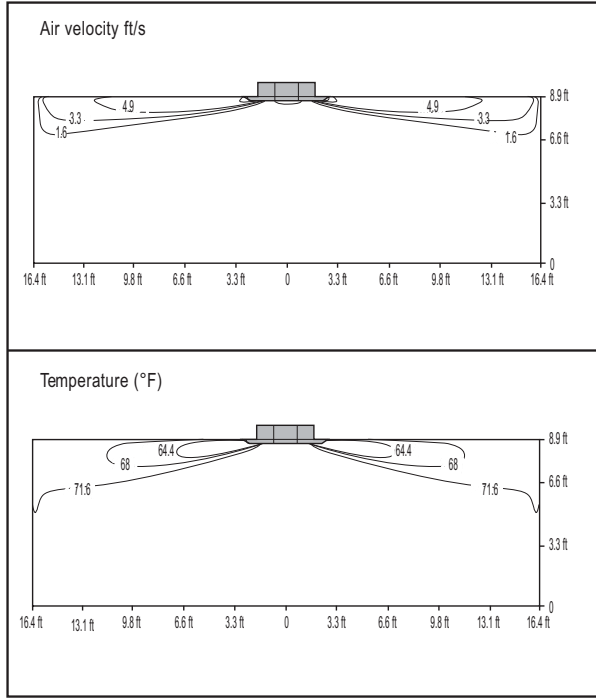

Cooling

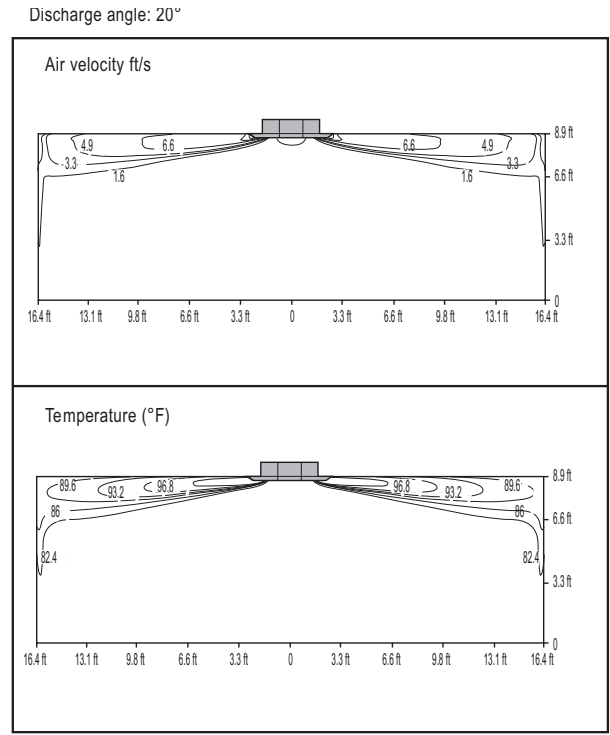

Heating

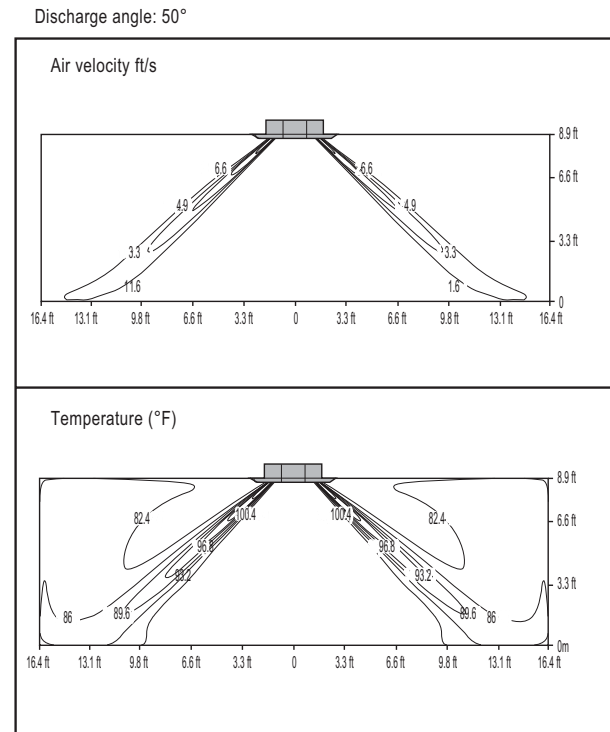
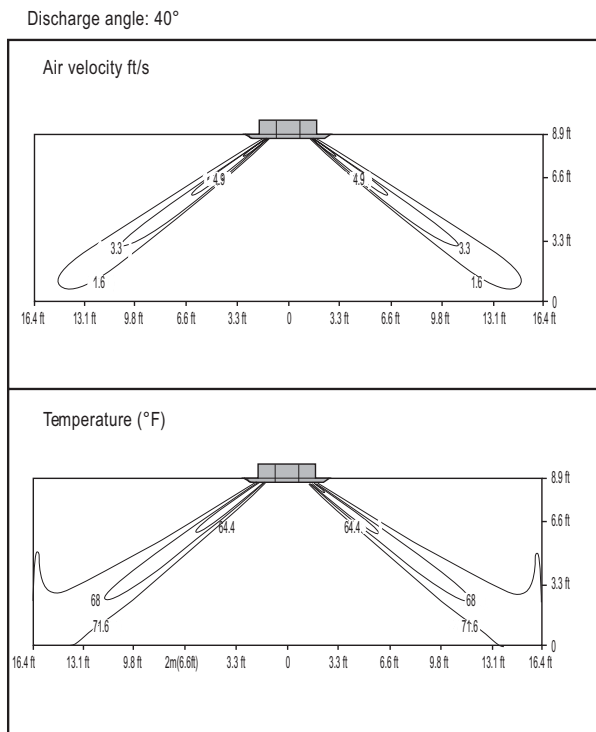

The standard setup height is 8.9 ft. The charts above show the measurement distribution at the ceiling height of 8.9 ft with a high fan operating mode.

# FOUR-WAY CEILING CASSETTE



## Air Velocity / Temperature Distribution

ARNU073TNA4, ARNU093TNA4, ARNU123TNA4, ARNU153TNA4

Figure 64: ARNU073TNA4 and ARNU093TNA4, continued.

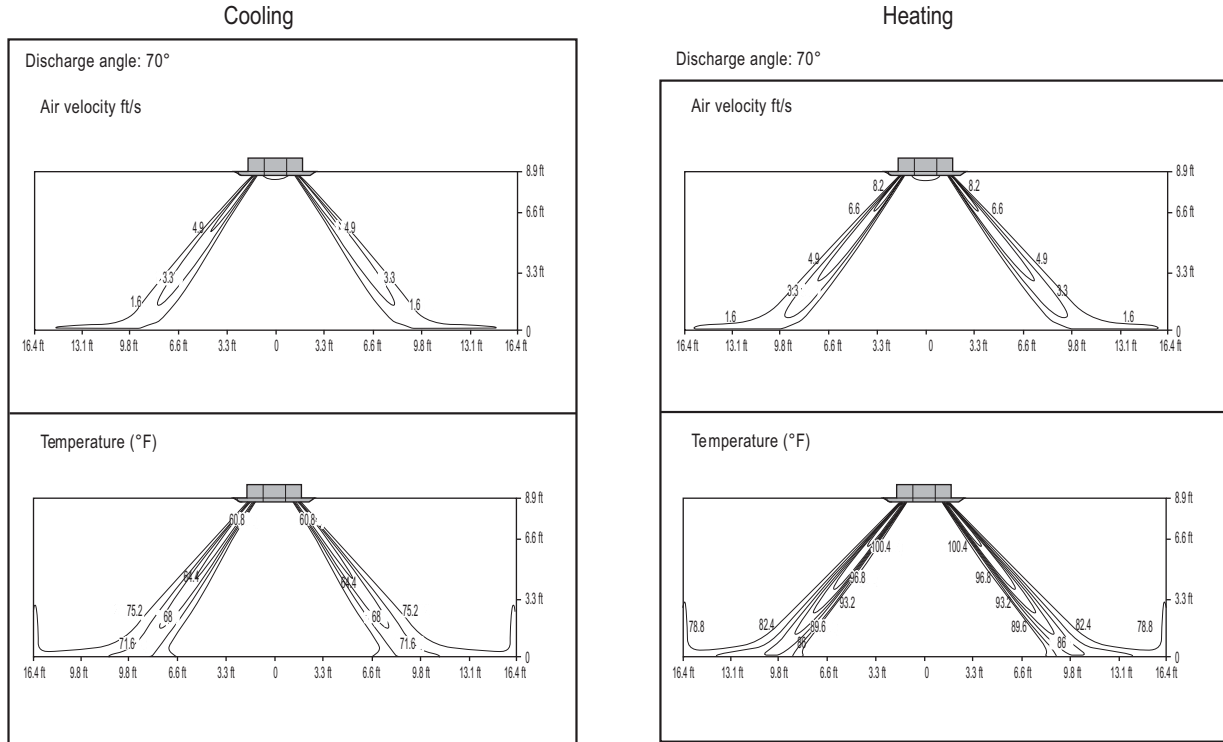
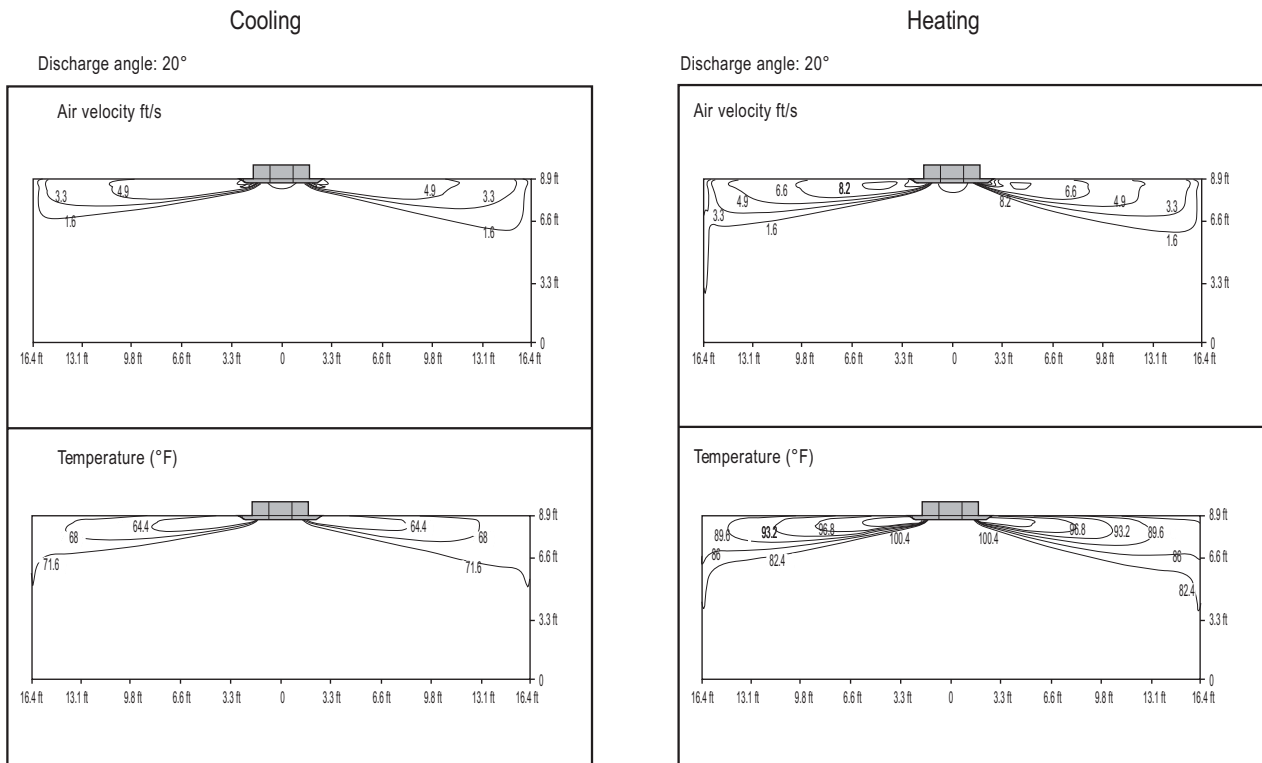

Figure 65: ARNU123TNA4 and ARNU153TNA4.



The standard setup height is 8.9 ft. The charts above show the measurement distribution at the ceiling height of 8.9 ft with a high fan operating mode.



Figure 66: ARNU123TNA4 and ARNU153TNA4, continued.

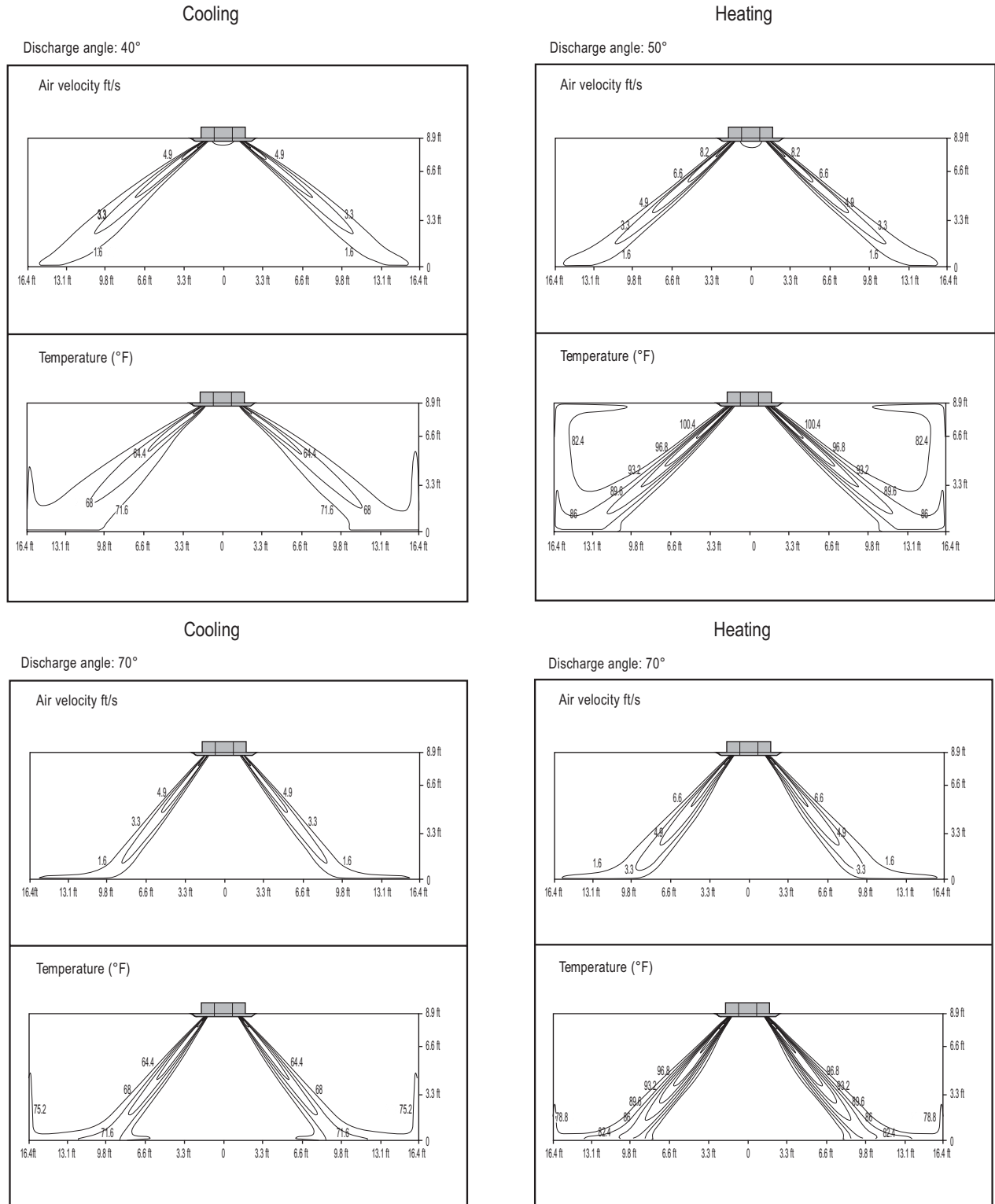

The standard setup height is 8.9 ft. The charts above show the measurement distribution at the ceiling height of 8.9 ft with a high fan operating mode.

# FOUR-WAY CEILING CASSETTE



## Air Velocity / Temperature Distribution

### ARNU183TNA4

Figure 67: ARNU183TNA4.

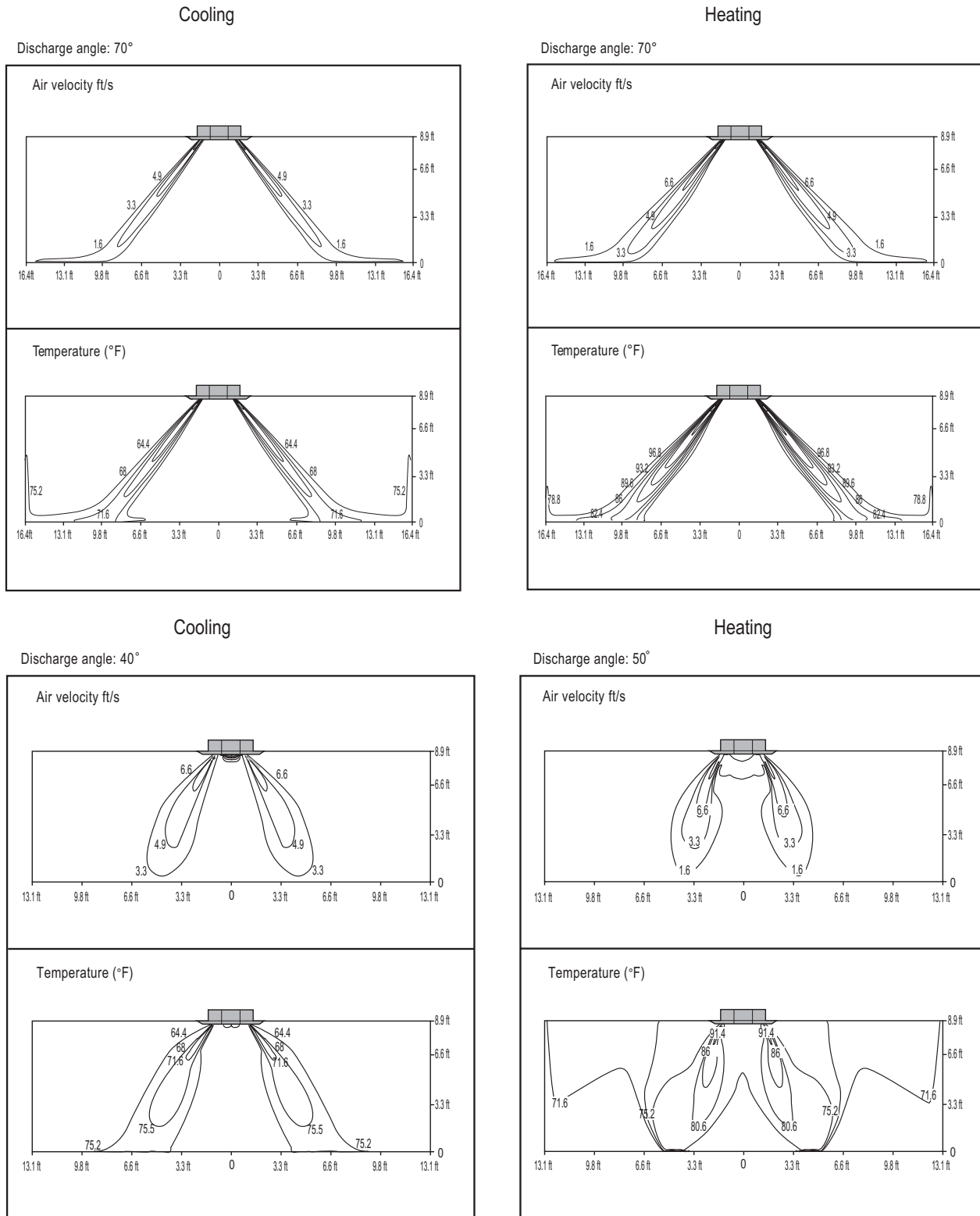

The standard setup height is 8.9 ft. The charts above show the measurement distribution at the ceiling height of 8.9 ft with a high fan operating mode.





Figure 68: ARNU183TNA4, continued.

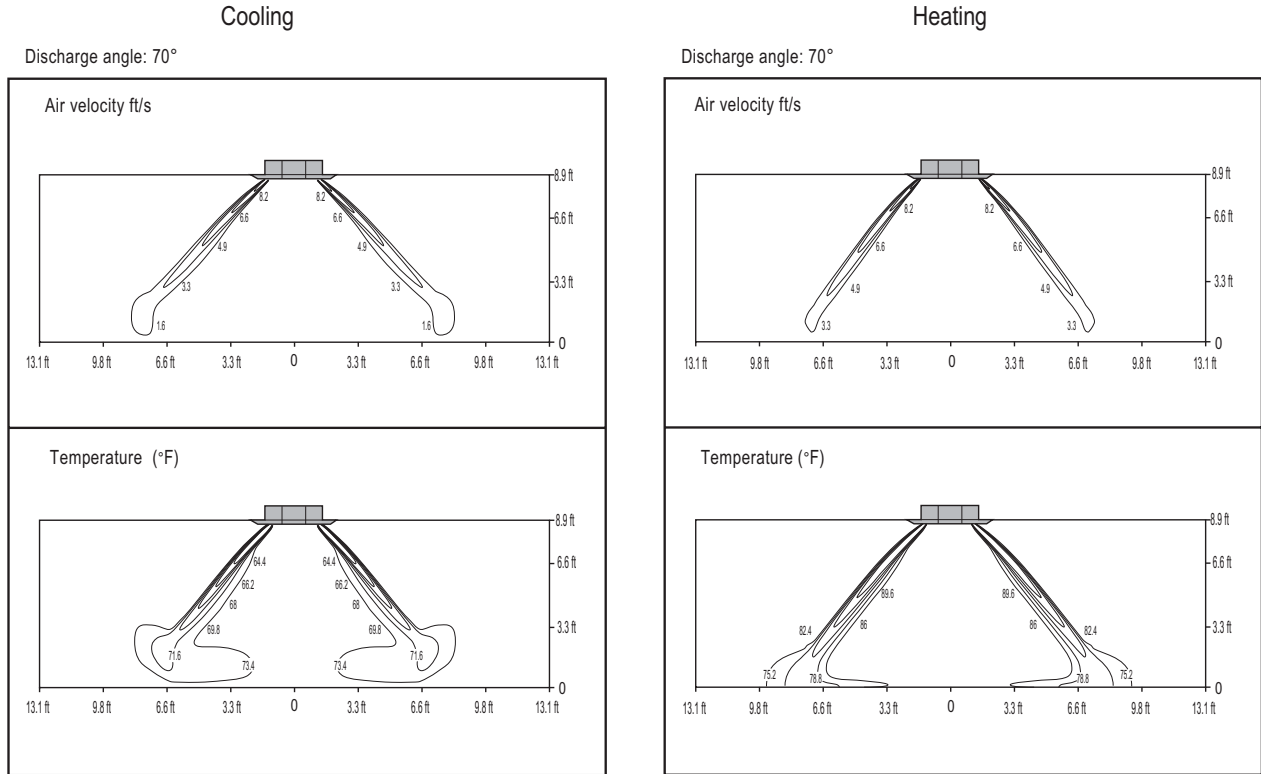
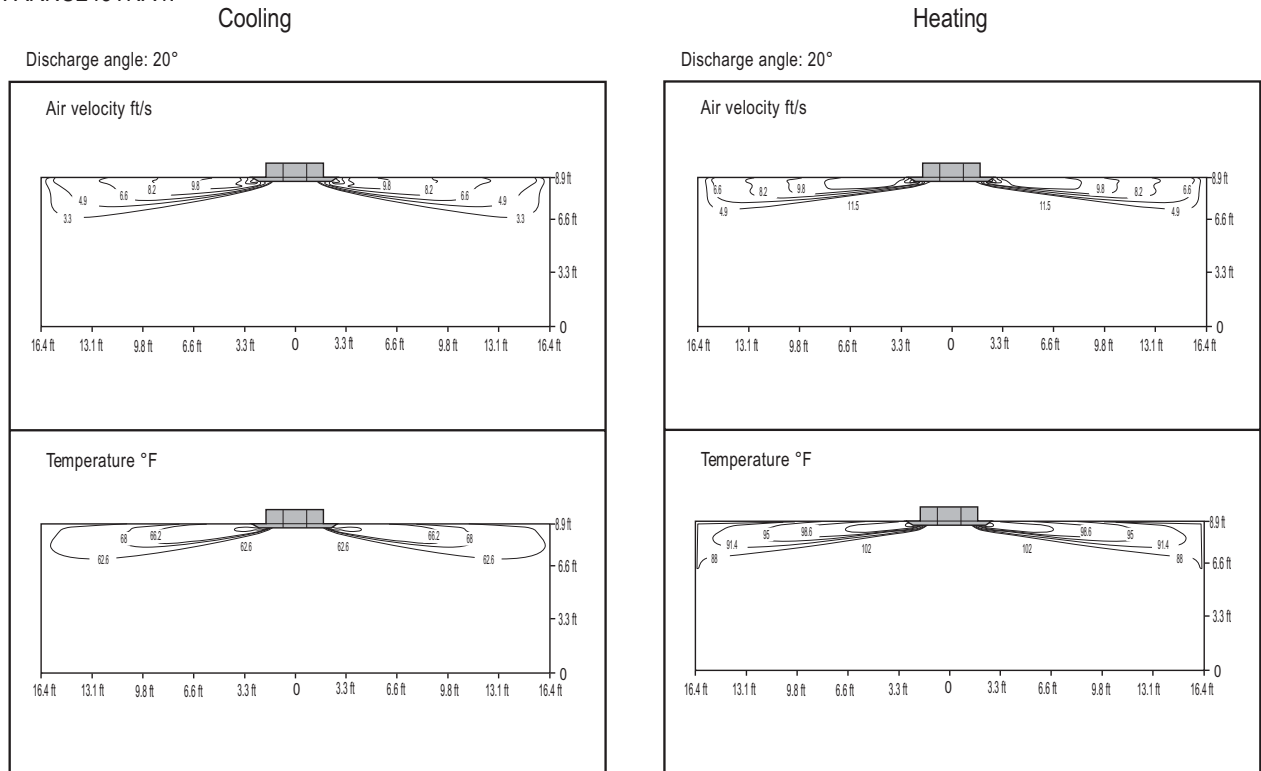

Figure 69: ARNU243TNA4.



The standard setup height is 8.9 ft. The charts above show the measurement distribution at the ceiling height of 8.9 ft with a high fan operating mode.

# FOUR-WAY CEILING CASSETTE



## Air Velocity / Temperature Distribution

### ARNU243TNA4

Figure 70: ARNU243TNA4, continued.

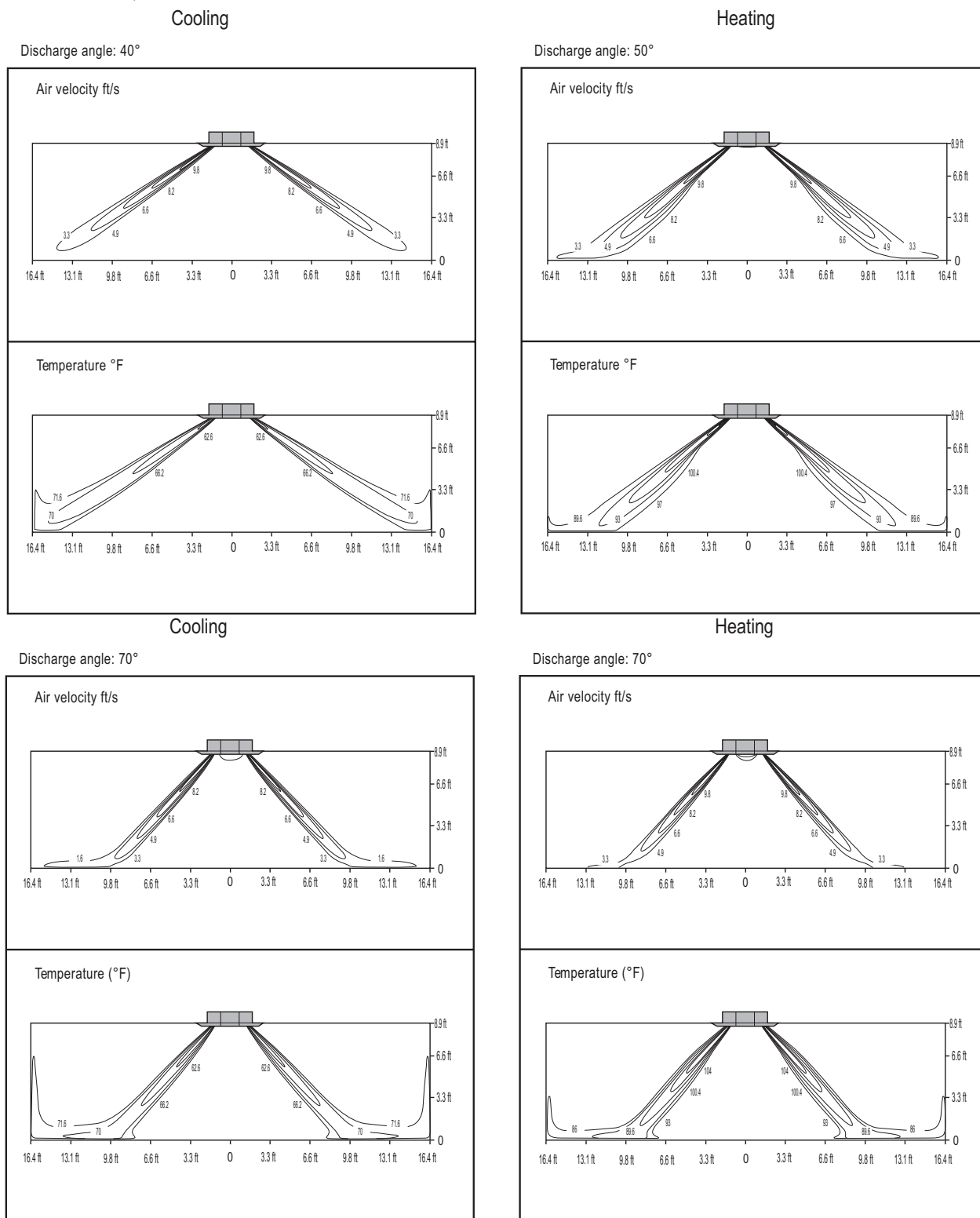

The standard setup height is 8.9 ft. The charts above show the measurement distribution at the ceiling height of 8.9 ft with a high fan operating mode.



Figure 71: ARNU283TMA4.

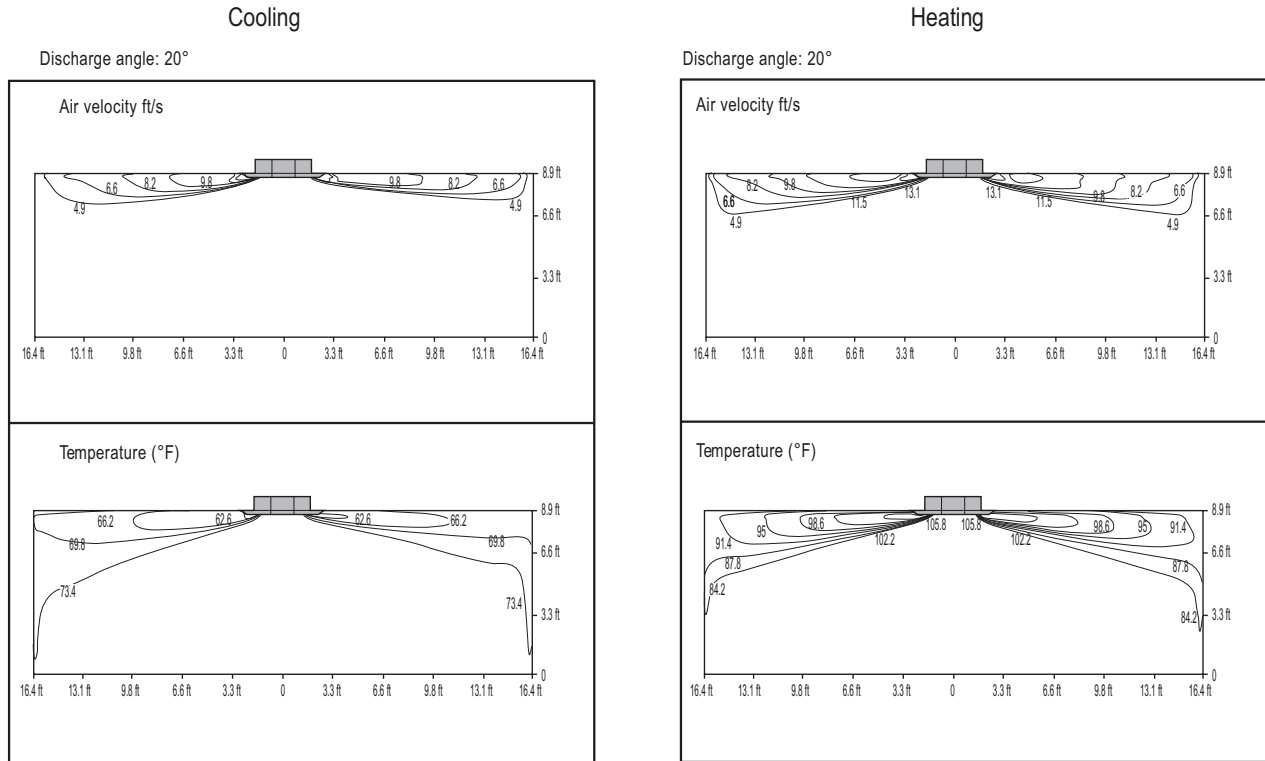

The standard setup height is 8.9 ft. The charts above show the measurement distribution at the ceiling height of 8.9 ft with a high fan operating mode.

# FOUR-WAY CEILING CASSETTE



## Air Velocity / Temperature Distribution ARNU283TMA4

Figure 72: ARNU283TMA4, continued.

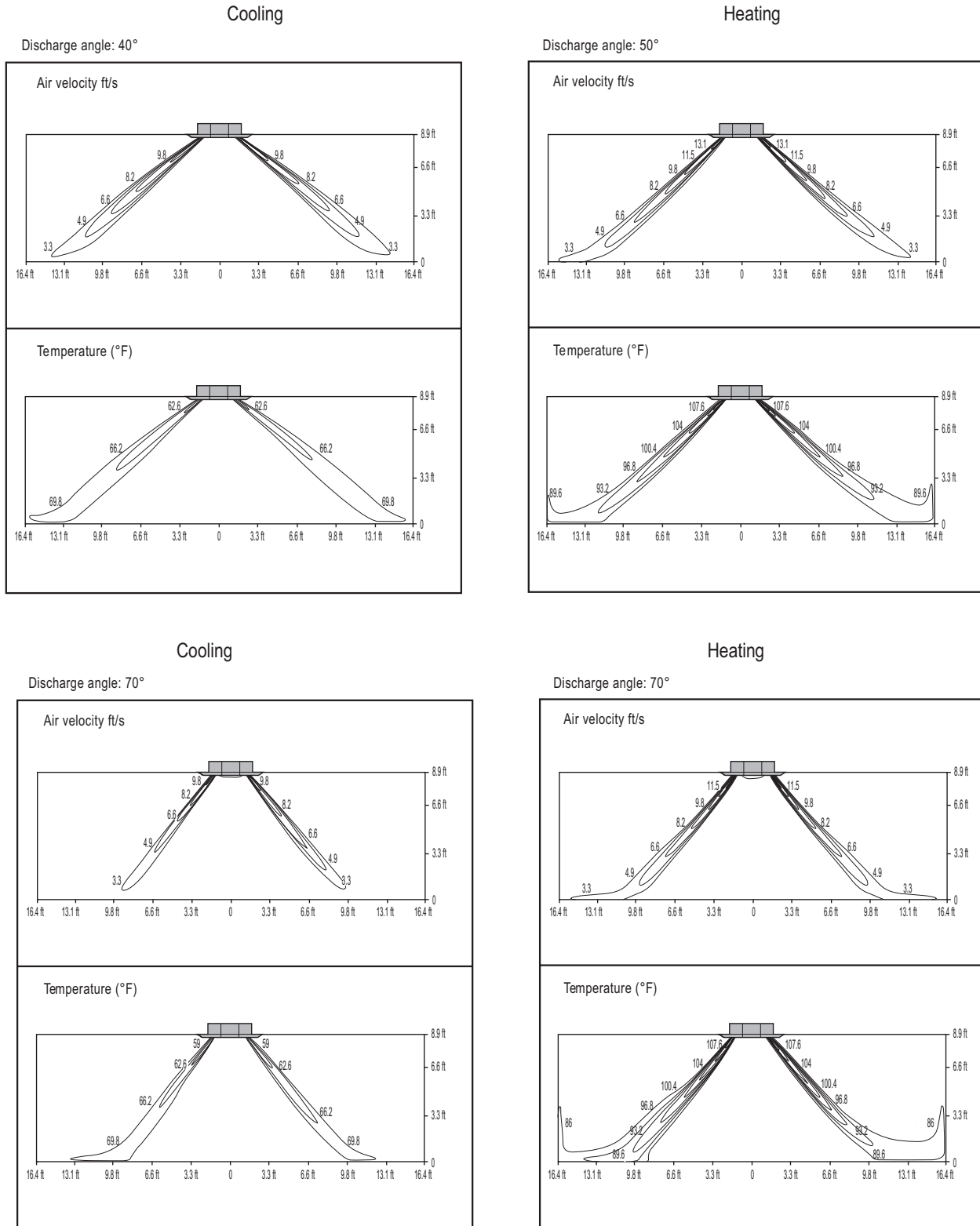

The standard setup height is 8.9 ft. The charts above show the measurement distribution at the ceiling height of 8.9 ft with a high fan operating mode.



Figure 73: ARNU363TMA4.

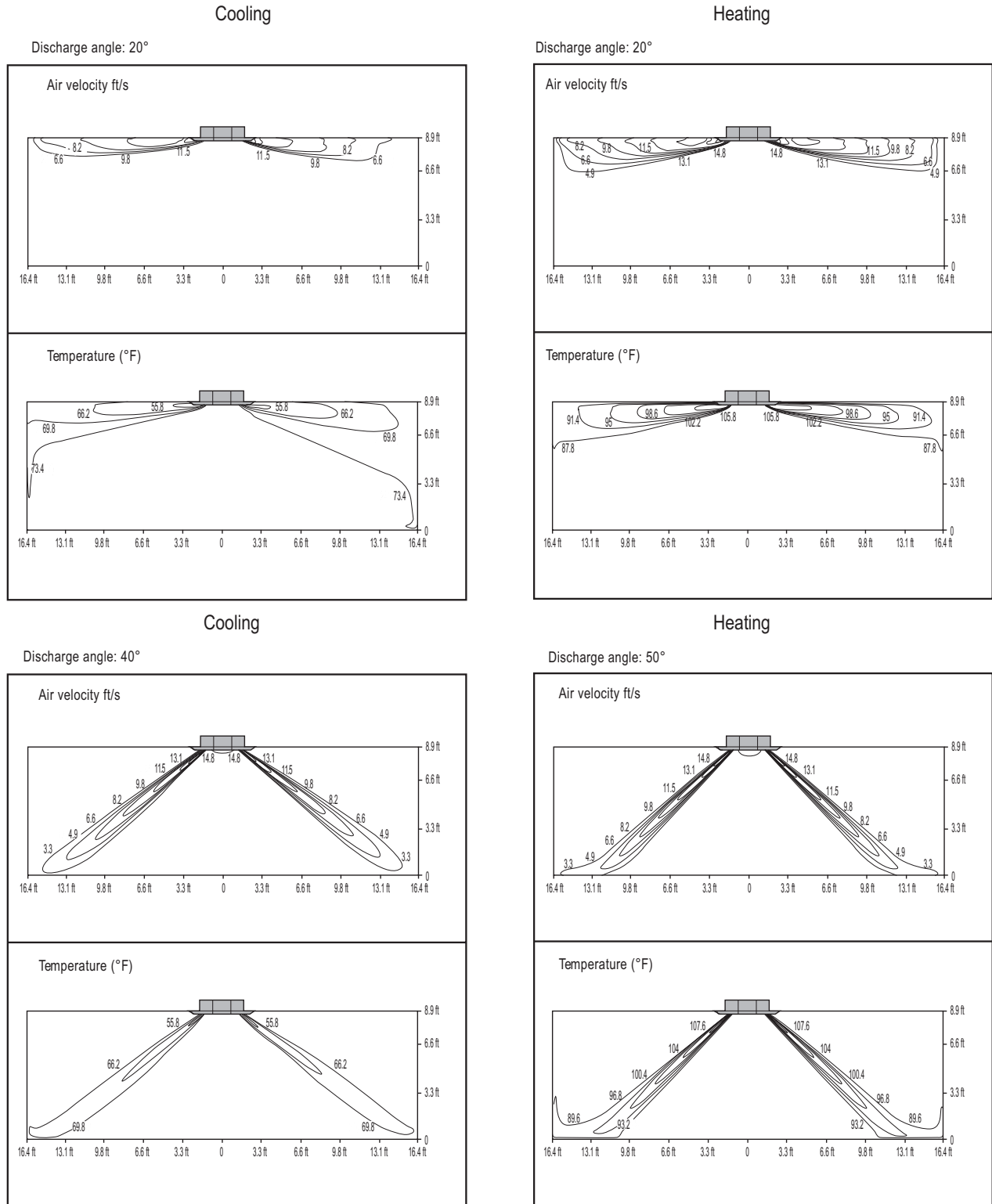

The standard setup height is 8.9 ft. The charts above show the measurement distribution at the ceiling height of 8.9 ft with a high fan operating mode.

# FOUR-WAY CEILING CASSETTE



## Air Velocity / Temperature Distribution ARNU363TMA4, ARNU423TMC4

Figure 75: ARNU363TMA4, continued.

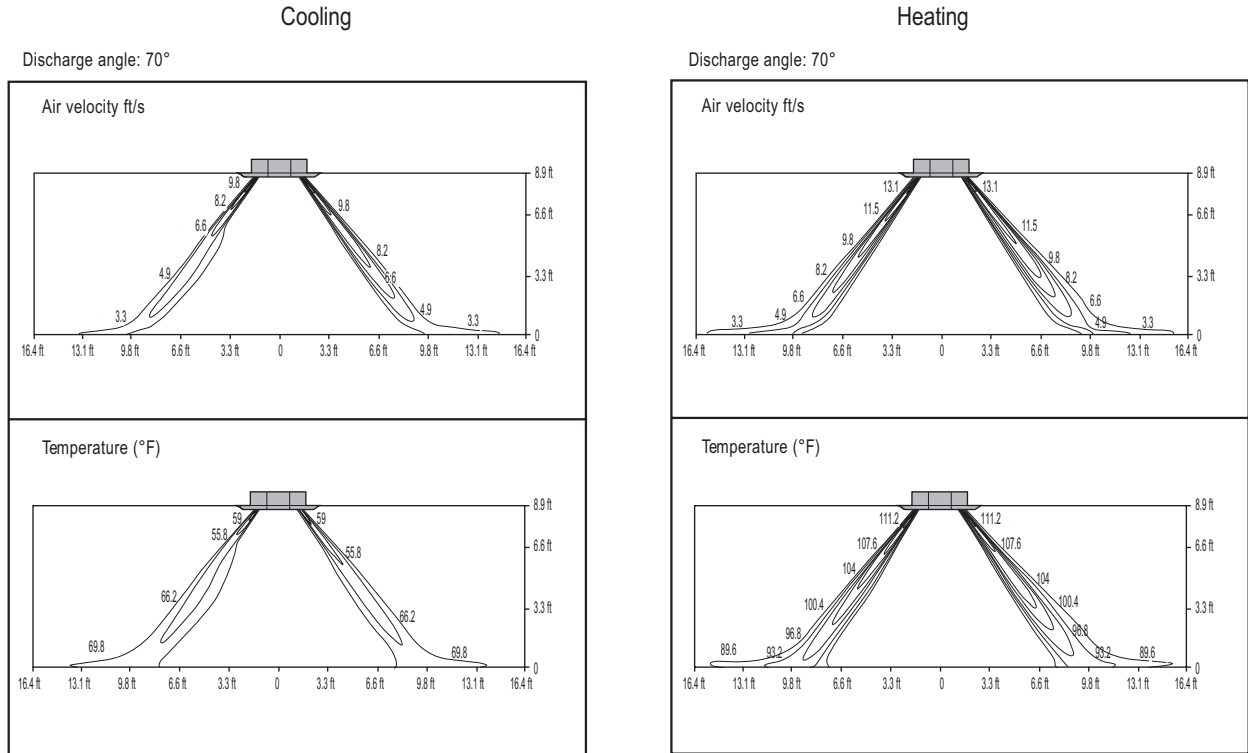
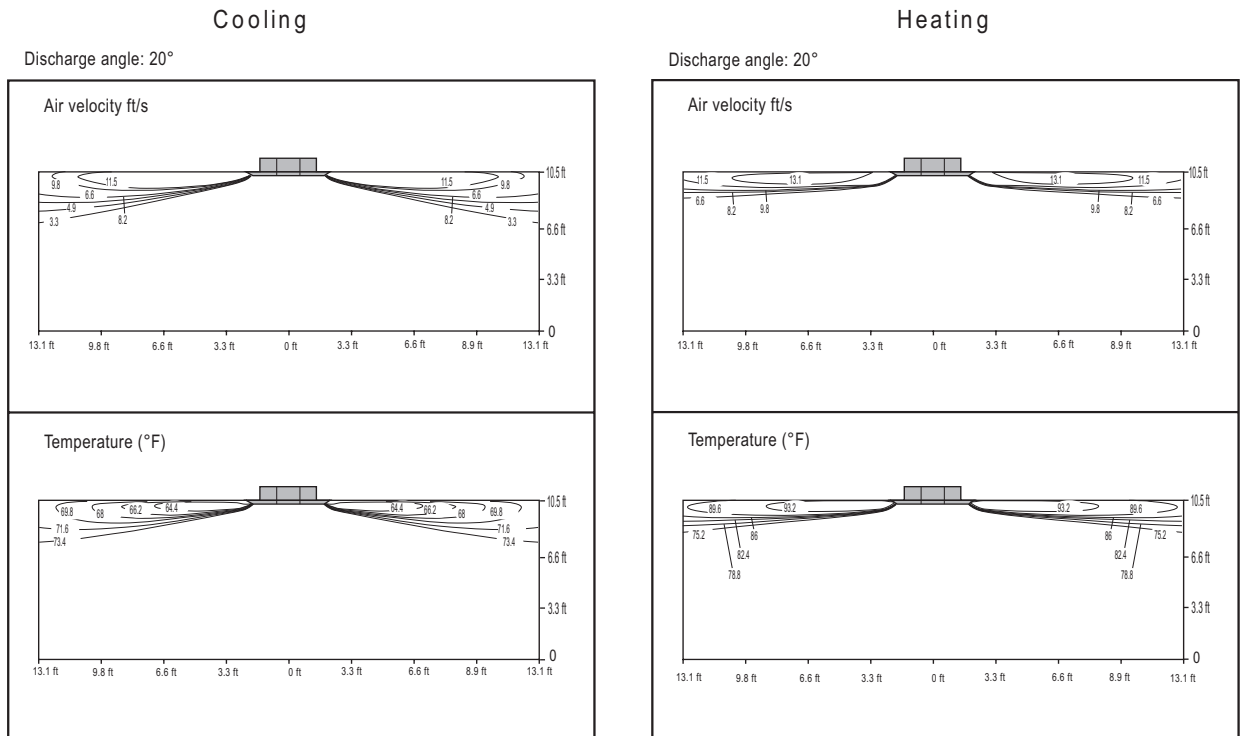

Figure 74: ARNU423TMC4.



The standard setup height is 8.9 ft. The charts above show the measurement distribution at the ceiling height of 8.9 ft with a high fan operating mode.



Figure 76: ARNU423TMC4, continued.

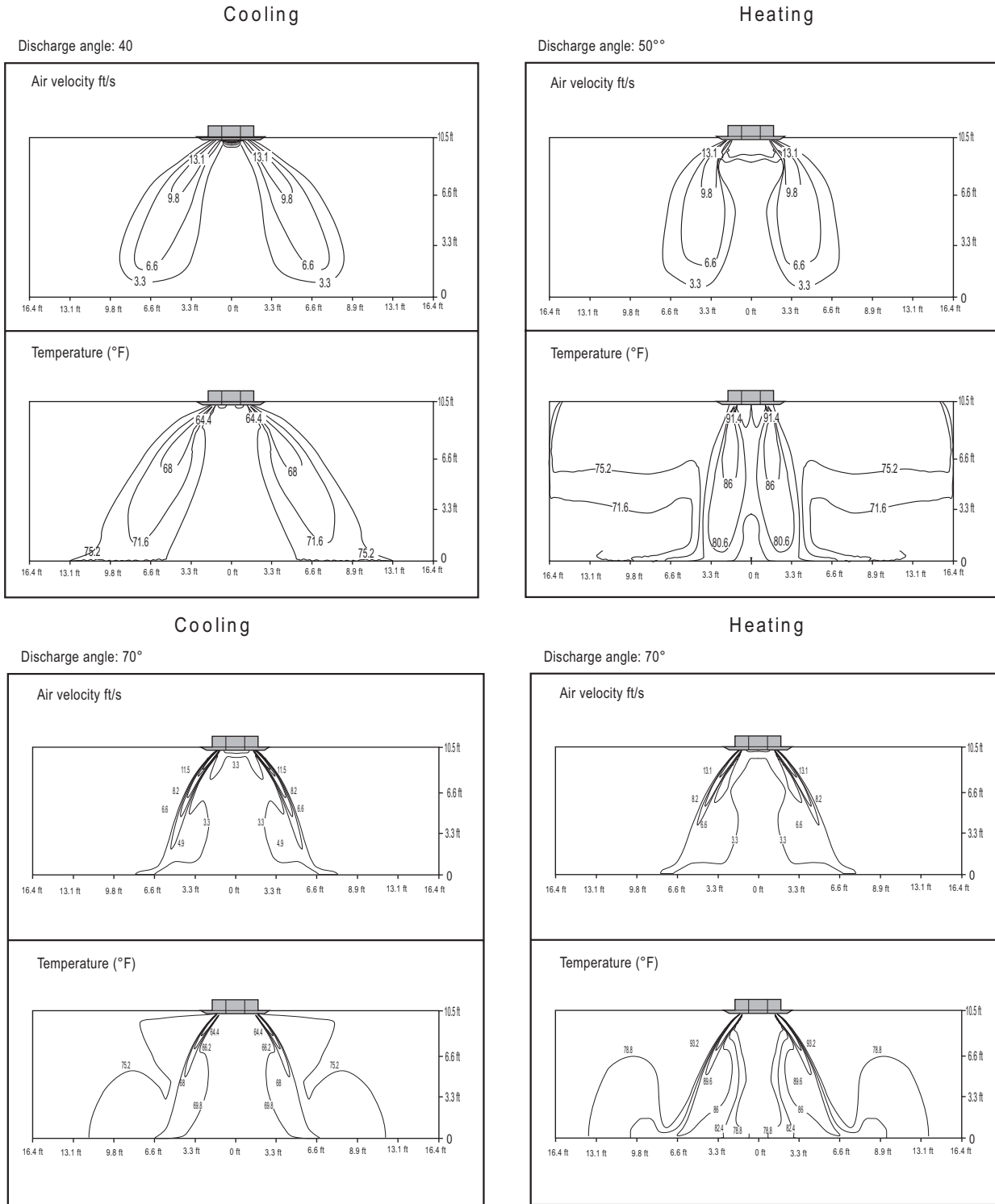

The standard setup height is 8.9 ft. The charts above show the measurement distribution at the ceiling height of 8.9 ft with a high fan operating mode.

# FOUR-WAY CEILING CASSETTE



## Air Velocity / Temperature Distribution

### ARNU483TMC4

Figure 77: ARNU483TMC4.

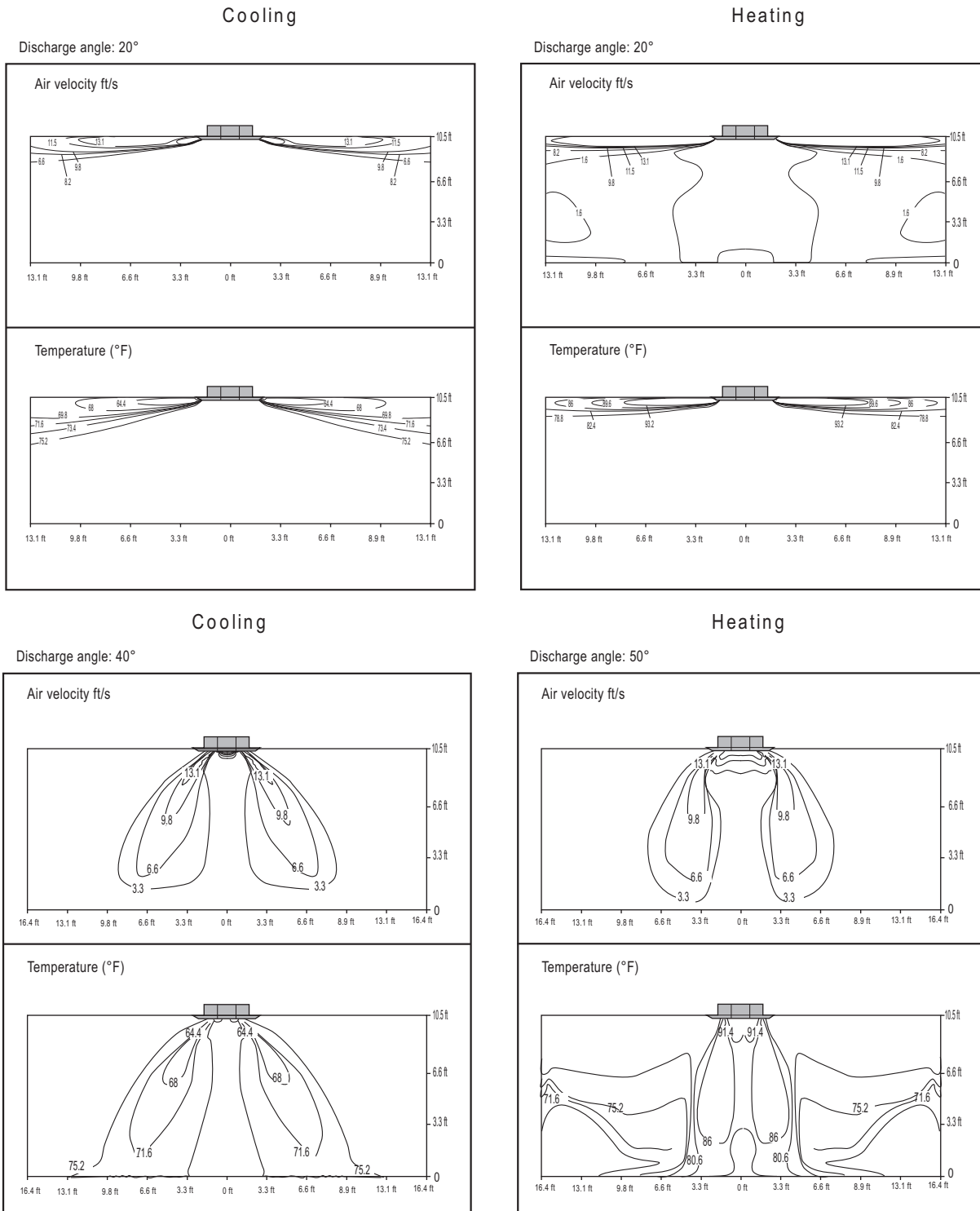

The standard setup height is 8.9 ft. The charts above show the measurement distribution at the ceiling height of 8.9 ft with a high fan operating mode.



Figure 78: ARNU483TMC4, continued.

Cooling

Heating

Discharge angle: 70°

Discharge angle: 70°

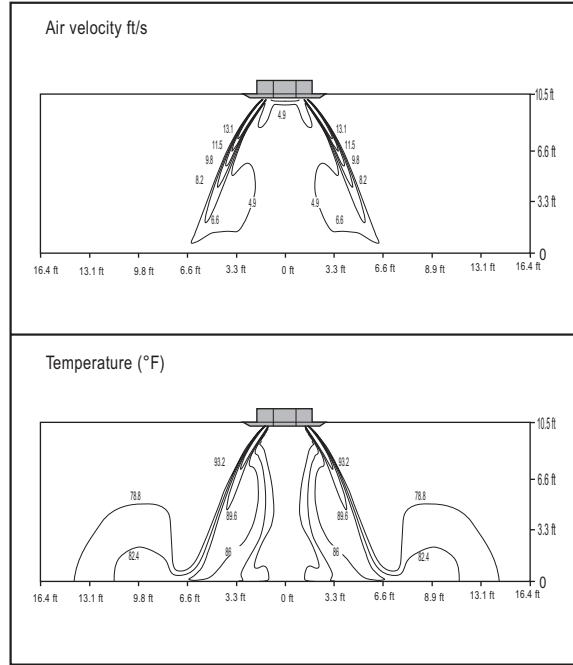
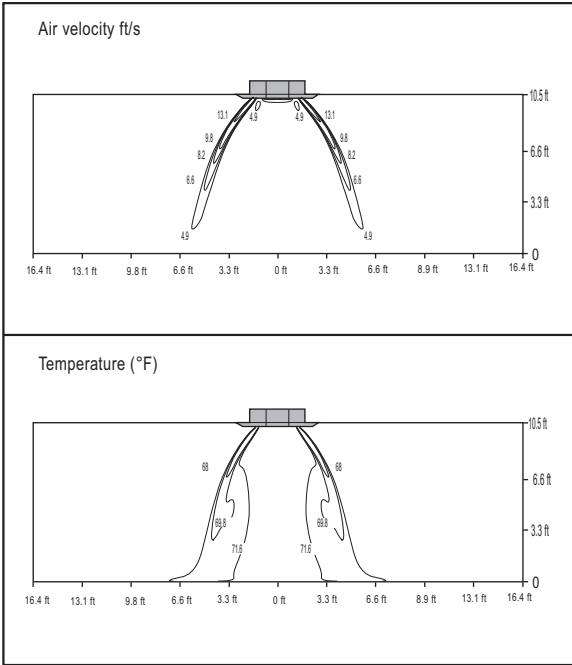

The standard setup height is 8.9 ft. The charts above show the measurement distribution at the ceiling height of 8.9 ft with a high fan operating mode.

# FOUR-WAY CEILING CASSETTE



Fresh Air Ventilation

TR, TQ Frame

Figure 79: TR Frame Fresh Air Ventilation.

Fresh Air Ventilation (with PTVK430)

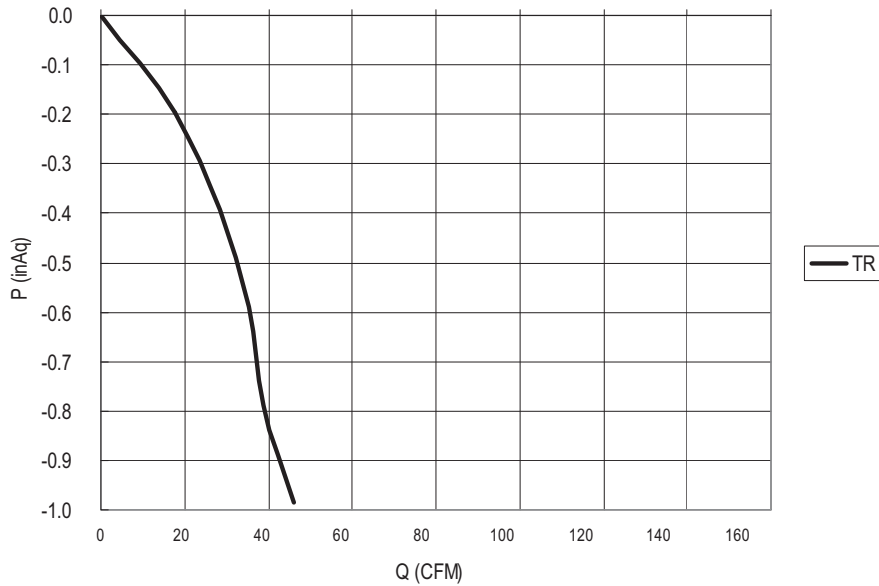

Figure 80: TQ Frame Fresh Air Ventilation.

Fresh Air Ventilation (with PTVK430)

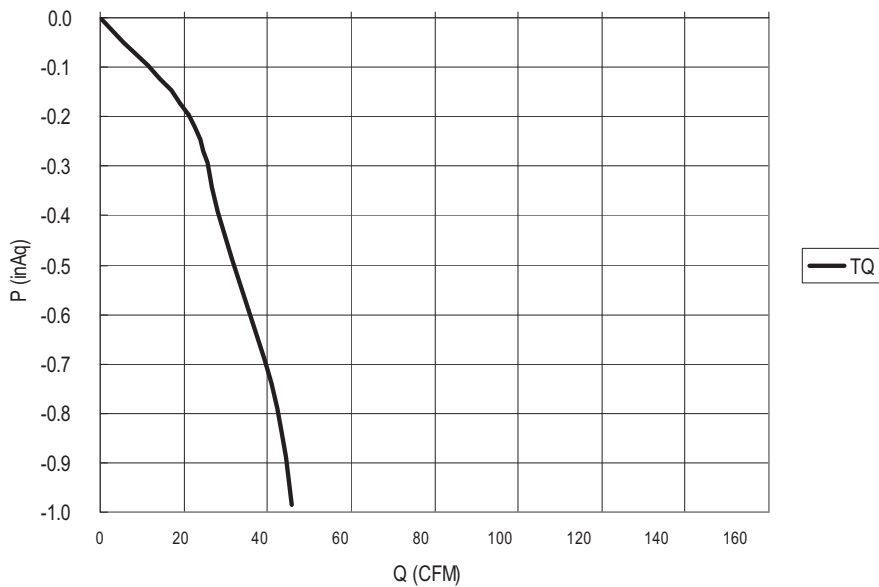

Figure 81: TN and TM Frame Fresh Air Ventilation with PTVK430 Accessory.

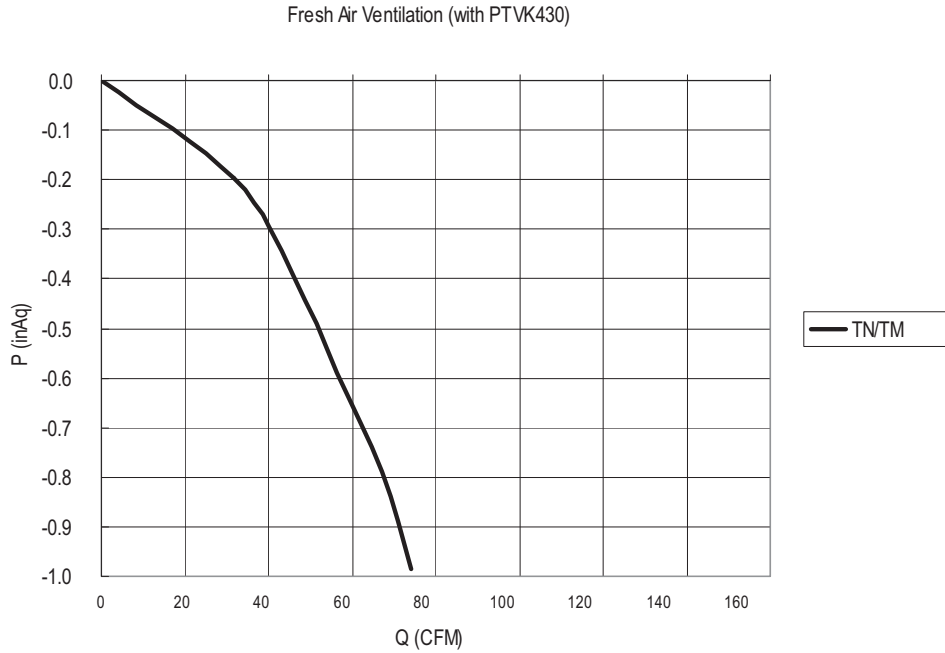
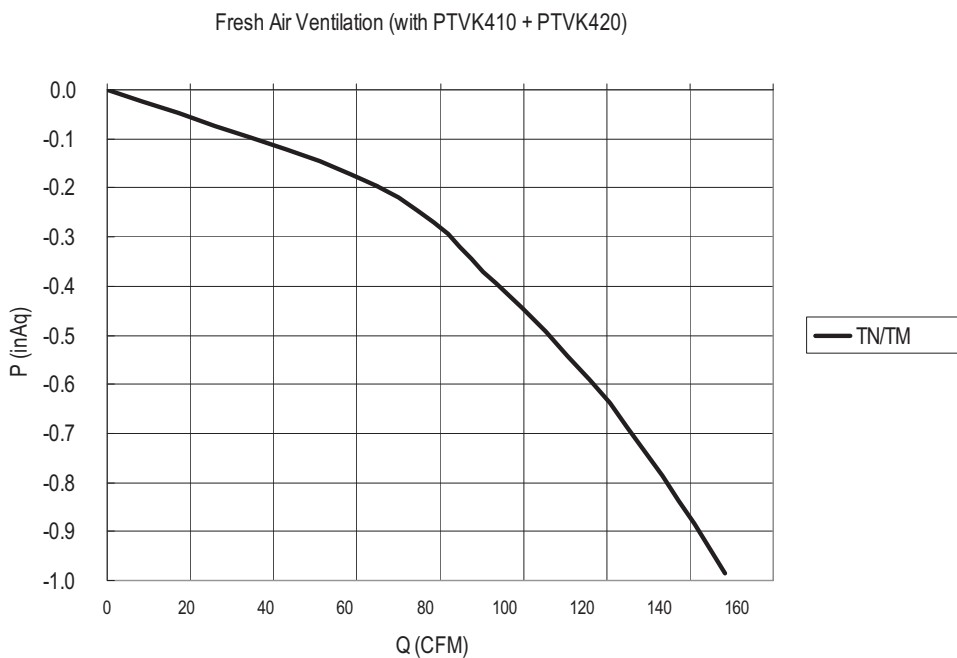

Figure 82: TN and TM Frame Fresh Air Ventilation with PTVK410 + PTVK420 Accessories.



# FOUR-WAY CEILING CASSETTE



## Cooling Capacity Tables

### ARNU053TRD4, ARNU073TRD4

Table 40: ARNU053TRD4, ARNU073TRD4 Cooling Capacity Table.

Model No. / Capacity Index	Outdoor Air Temp. (°F DB)	Indoor Air Temperature (°F DB / WB)													
		68 / 57		73 / 61		79 / 64		80 / 67		85 / 70		88 / 73		91 / 76	
		TC MBh	SHC MBh	TC MBh	SHC MBh	TC MBh	SHC MBh	TC MBh	SHC MBh	TC MBh	SHC MBh	TC MBh	SHC MBh	TC MBh	SHC MBh
ARNU053TRD4 / 5.5	-9.9	3.6	3.0	4.4	3.4	5.0	3.7	5.5	3.9	6.2	4.2	6.6	4.1	7.1	4.1
	-5	3.6	3.0	4.4	3.4	5.0	3.7	5.5	3.9	6.2	4.2	6.6	4.1	7.1	4.1
	0	3.6	3.0	4.4	3.4	5.0	3.7	5.5	3.9	6.2	4.2	6.6	4.1	7.1	4.1
	5	3.6	3.0	4.4	3.4	5.0	3.7	5.5	3.9	6.2	4.2	6.6	4.1	7.1	4.1
	10	3.6	3.0	4.4	3.4	5.0	3.7	5.5	3.9	6.2	4.2	6.6	4.1	7.1	4.1
	14	3.6	3.0	4.4	3.4	5.0	3.7	5.5	3.9	6.2	4.2	6.6	4.1	7.1	4.1
	20	3.6	3.0	4.4	3.4	5.0	3.7	5.5	3.9	6.2	4.2	6.6	4.1	7.1	4.1
	23	3.6	3.0	4.4	3.4	5.0	3.7	5.5	3.9	6.2	4.2	6.6	4.1	7.1	4.1
	25	3.6	3.0	4.4	3.4	5.0	3.7	5.5	3.9	6.2	4.2	6.6	4.1	7.1	4.1
	30	3.6	3.0	4.4	3.4	5.0	3.7	5.5	3.9	6.2	4.2	6.6	4.1	7.1	4.1
	35	3.6	3.0	4.4	3.4	5.0	3.7	5.5	3.9	6.2	4.2	6.6	4.1	7.1	4.1
	40	3.6	3.0	4.4	3.4	5.0	3.7	5.5	3.9	6.2	4.2	6.6	4.1	7.1	4.1
	45	3.6	3.0	4.4	3.4	5.0	3.7	5.5	3.9	6.2	4.2	6.6	4.1	7.1	4.1
	50	3.6	3.0	4.4	3.4	5.0	3.7	5.5	3.9	6.2	4.2	6.6	4.1	7.1	4.1
	55	3.6	3.0	4.4	3.4	5.0	3.7	5.5	3.9	6.2	4.2	6.6	4.1	7.1	4.1
	60	3.6	3.0	4.4	3.4	5.0	3.7	5.5	3.9	6.2	4.2	6.6	4.1	7.0	4.1
	65	3.6	3.0	4.4	3.4	5.0	3.7	5.5	3.9	6.2	4.2	6.6	4.1	6.9	4.1
	70	3.6	3.0	4.4	3.4	5.0	3.7	5.5	3.9	6.2	4.2	6.6	4.1	6.8	4.0
	75	3.6	3.0	4.4	3.4	5.0	3.7	5.5	3.9	6.2	4.2	6.6	4.1	6.6	3.9
	80	3.6	3.0	4.4	3.4	5.0	3.7	5.5	3.9	6.2	4.2	6.4	4.1	6.5	3.9
	85	3.6	3.0	4.4	3.4	5.0	3.7	5.5	3.9	6.1	4.1	6.2	3.9	6.3	3.7
90	3.6	3.0	4.4	3.4	5.0	3.7	5.5	3.9	6.0	4.1	6.1	3.9	6.2	3.7	
95	3.6	3.0	4.4	3.4	5.0	3.7	<b>5.5</b>	<b>3.9</b>	5.9	4.1	6.0	3.9	6.1	3.6	
100	3.6	3.0	4.4	3.4	5.0	3.7	5.5	3.9	5.8	4.0	5.9	3.8	6.0	3.6	
105	3.6	3.0	4.2	3.3	4.7	3.5	5.3	3.7	5.5	3.7	5.7	3.7	5.8	3.5	
110	3.5	2.9	4.0	3.1	4.4	3.3	5.0	3.5	5.2	3.5	5.4	3.5	5.6	3.4	
115	3.4	2.8	3.8	2.9	4.1	3.1	4.7	3.3	4.9	3.3	5.1	3.3	5.4	3.3	
118	3.4	2.7	3.6	2.8	3.9	2.9	4.5	3.2	4.6	3.2	4.9	3.2	5.2	3.1	
122	3.3	2.6	3.4	2.6	3.7	2.7	4.2	3.0	4.4	3.0	4.6	3.0	5.0	3.0	
ARNU073TRD4 / 7.5	-9.9	4.9	4.1	6.0	4.8	6.8	5.1	7.5	5.4	8.4	5.8	8.9	5.7	9.7	5.7
	-5	4.9	4.1	6.0	4.8	6.8	5.1	7.5	5.4	8.4	5.8	8.9	5.7	9.7	5.7
	0	4.9	4.1	6.0	4.8	6.8	5.1	7.5	5.4	8.4	5.8	8.9	5.7	9.7	5.7
	5	4.9	4.1	6.0	4.8	6.8	5.1	7.5	5.4	8.4	5.8	8.9	5.7	9.7	5.7
	10	4.9	4.1	6.0	4.8	6.8	5.1	7.5	5.4	8.4	5.8	8.9	5.7	9.7	5.7
	14	4.9	4.1	6.0	4.8	6.8	5.1	7.5	5.4	8.4	5.8	8.9	5.7	9.7	5.7
	20	4.9	4.1	6.0	4.8	6.8	5.1	7.5	5.4	8.4	5.8	8.9	5.7	9.7	5.7
	23	4.9	4.1	6.0	4.8	6.8	5.1	7.5	5.4	8.4	5.8	8.9	5.7	9.7	5.7
	25	4.9	4.1	6.0	4.8	6.8	5.1	7.5	5.4	8.4	5.8	8.9	5.7	9.7	5.7
	30	4.9	4.1	6.0	4.8	6.8	5.1	7.5	5.4	8.4	5.8	8.9	5.7	9.7	5.7
	35	4.9	4.1	6.0	4.8	6.8	5.1	7.5	5.4	8.4	5.8	8.9	5.7	9.7	5.7
	40	4.9	4.1	6.0	4.8	6.8	5.1	7.5	5.4	8.4	5.8	8.9	5.7	9.7	5.7
	45	4.9	4.1	6.0	4.8	6.8	5.1	7.5	5.4	8.4	5.8	8.9	5.7	9.7	5.7
	50	4.9	4.1	6.0	4.8	6.8	5.1	7.5	5.4	8.4	5.8	8.9	5.7	9.7	5.7
	55	4.9	4.1	6.0	4.8	6.8	5.1	7.5	5.4	8.4	5.8	8.9	5.7	9.7	5.7
	60	4.9	4.1	6.0	4.8	6.8	5.1	7.5	5.4	8.4	5.8	8.9	5.7	9.6	5.7
	65	4.9	4.1	6.0	4.8	6.8	5.1	7.5	5.4	8.4	5.8	8.9	5.7	9.4	5.6
	70	4.9	4.1	6.0	4.8	6.8	5.1	7.5	5.4	8.4	5.8	8.9	5.7	9.3	5.5
	75	4.9	4.1	6.0	4.8	6.8	5.1	7.5	5.4	8.4	5.8	8.9	5.7	9.1	5.4
	80	4.9	4.1	6.0	4.8	6.8	5.1	7.5	5.4	8.4	5.8	8.7	5.7	8.8	5.4
	85	4.9	4.1	6.0	4.8	6.8	5.1	7.5	5.4	8.3	5.7	8.4	5.5	8.6	5.2
90	4.9	4.1	6.0	4.8	6.8	5.1	7.5	5.4	8.2	5.6	8.3	5.4	8.4	5.1	
95	4.9	4.1	6.0	4.8	6.8	5.1	<b>7.5</b>	<b>5.4</b>	8.0	5.6	8.2	5.3	8.3	5.0	
100	4.9	4.1	6.0	4.8	6.8	5.1	7.5	5.4	7.9	5.5	8.0	5.3	8.2	5.0	
105	4.9	4.1	5.7	4.5	6.4	4.9	7.2	5.2	7.5	5.2	7.7	5.1	7.9	4.9	
110	4.8	4.0	5.4	4.3	6.0	4.5	6.8	4.9	7.1	4.9	7.3	4.9	7.7	4.7	
115	4.7	3.9	5.1	4.1	5.6	4.2	6.3	4.6	6.6	4.6	7.0	4.6	7.4	4.5	
118	4.6	3.8	4.9	3.9	5.4	4.0	6.1	4.4	6.3	4.4	6.7	4.4	7.1	4.4	
122	4.5	3.7	4.6	3.7	5.1	3.8	5.8	4.2	6.0	4.2	6.3	4.2	6.8	4.2	

TC: Total Capacity (MBh); SHC: Sensible Heat Capacity (MBh).

The System Combination Ratio must be between 50–130%.

Rated capacity is certified under AHRI Standard 1230. Ratings are subject to change without notice.

Current certified ratings are available at [www.ahridirectory.org](http://www.ahridirectory.org).

For outdoor unit performance data, see the respective outdoor unit performance data manuals on [www.lghvac.com](http://www.lghvac.com).

Low ambient performance with LGRED® heat technology is included in Multi V 5 air source units produced after February 2019.

Due to our policy of continuous product innovation, some specifications may change without notification.  
© LG Electronics U.S.A., Inc., Englewood Cliffs, NJ. All rights reserved. "LG" is a registered trademark of LG Corp.



Table 41: ARNU093TRD4 Cooling Capacity Table.

Model No. / Capacity Index	Outdoor Air Temp. (°F DB)	Indoor Air Temperature (°F DB / WB)													
		68 / 57		73 / 61		79 / 64		80 / 67		85 / 70		88 / 73		91 / 76	
		TC MBh	SHC MBh	TC MBh	SHC MBh	TC MBh	SHC MBh	TC MBh	SHC MBh	TC MBh	SHC MBh	TC MBh	SHC MBh	TC MBh	SHC MBh
ARNU093TRD4 / 9.6	-9.9	6.3	5.3	7.7	6.1	8.6	6.5	9.6	6.9	10.8	7.4	11.4	7.3	12.4	7.3
	-5	6.3	5.3	7.7	6.1	8.6	6.5	9.6	6.9	10.8	7.4	11.4	7.3	12.4	7.3
	0	6.3	5.3	7.7	6.1	8.6	6.5	9.6	6.9	10.8	7.4	11.4	7.3	12.4	7.3
	5	6.3	5.3	7.7	6.1	8.6	6.5	9.6	6.9	10.8	7.4	11.4	7.3	12.4	7.3
	10	6.3	5.3	7.7	6.1	8.6	6.5	9.6	6.9	10.8	7.4	11.4	7.3	12.4	7.3
	14	6.3	5.3	7.7	6.1	8.6	6.5	9.6	6.9	10.8	7.4	11.4	7.3	12.4	7.3
	20	6.3	5.3	7.7	6.1	8.6	6.5	9.6	6.9	10.8	7.4	11.4	7.3	12.4	7.3
	23	6.3	5.3	7.7	6.1	8.6	6.5	9.6	6.9	10.8	7.4	11.4	7.3	12.4	7.3
	25	6.3	5.3	7.7	6.1	8.6	6.5	9.6	6.9	10.8	7.4	11.4	7.3	12.4	7.3
	30	6.3	5.3	7.7	6.1	8.6	6.5	9.6	6.9	10.8	7.4	11.4	7.3	12.4	7.3
	35	6.3	5.3	7.7	6.1	8.6	6.5	9.6	6.9	10.8	7.4	11.4	7.3	12.4	7.3
	40	6.3	5.3	7.7	6.1	8.6	6.5	9.6	6.9	10.8	7.4	11.4	7.3	12.4	7.3
	45	6.3	5.3	7.7	6.1	8.6	6.5	9.6	6.9	10.8	7.4	11.4	7.3	12.4	7.3
	50	6.3	5.3	7.7	6.1	8.6	6.5	9.6	6.9	10.8	7.4	11.4	7.3	12.4	7.3
	55	6.3	5.3	7.7	6.1	8.6	6.5	9.6	6.9	10.8	7.4	11.4	7.3	12.4	7.3
	60	6.3	5.3	7.7	6.1	8.6	6.5	9.6	6.9	10.8	7.4	11.4	7.3	12.3	7.3
	65	6.3	5.3	7.7	6.1	8.6	6.5	9.6	6.9	10.8	7.4	11.4	7.3	12.1	7.2
	70	6.3	5.3	7.7	6.1	8.6	6.5	9.6	6.9	10.8	7.4	11.4	7.3	11.9	7.1
	75	6.3	5.3	7.7	6.1	8.6	6.5	9.6	6.9	10.8	7.4	11.4	7.3	11.6	6.9
	80	6.3	5.3	7.7	6.1	8.6	6.5	9.6	6.9	10.8	7.4	11.1	7.3	11.3	6.9
85	6.3	5.3	7.7	6.1	8.6	6.5	9.6	6.9	10.6	7.3	10.8	7.0	11.0	6.6	
90	6.3	5.3	7.7	6.1	8.6	6.5	9.6	6.9	10.5	7.2	10.6	6.9	10.8	6.5	
95	6.3	5.3	7.7	6.1	8.6	6.5	<b>9.6</b>	<b>6.9</b>	10.3	7.2	10.5	6.8	10.6	6.4	
100	6.3	5.3	7.7	6.1	8.6	6.5	9.6	6.9	10.1	7.1	10.3	6.7	10.5	6.4	
105	6.3	5.3	7.3	5.8	8.2	6.2	9.2	6.6	9.6	6.6	9.9	6.5	10.2	6.2	
110	6.2	5.1	6.9	5.5	7.7	5.8	8.6	6.2	9.0	6.2	9.4	6.2	9.8	6.0	
115	6.0	5.0	6.6	5.2	7.2	5.4	8.1	5.9	8.5	5.9	8.9	5.9	9.4	5.8	
118	5.9	4.8	6.2	4.9	6.9	5.1	7.8	5.6	8.1	5.6	8.5	5.6	9.0	5.6	
122	5.7	4.7	5.9	4.7	6.5	4.8	7.4	5.3	7.7	5.3	8.1	5.3	8.7	5.3	

TC: Total Capacity (MBh); SHC: Sensible Heat Capacity (MBh).  
 The System Combination Ratio must be between 50–130%.  
 Rated capacity is certified under AHRI Standard 1230. Ratings are subject to change without notice.  
 Current certified ratings are available at [www.ahridirectory.org](http://www.ahridirectory.org).

For outdoor unit performance data, see the respective outdoor unit performance data manuals on [www.lghvac.com](http://www.lghvac.com).

Low ambient performance with LGRED® heat technology is included in Multi V 5 air source units produced after February 2019.

# FOUR-WAY CEILING CASSETTE



## Cooling Capacity Tables

### ARNU123TRD4, ARNU153TQD4

Table 42: ARNU123TRD4, ARNU153TQD4 Cooling Capacity Table.

Model No. / Capacity Index	Outdoor Air Temp. (°F DB)	Indoor Air Temperature (°F DB / WB)													
		68 / 57		73 / 61		79 / 64		80 / 67		85 / 70		88 / 73		91 / 76	
		TC MBh	SHC MBh	TC MBh	SHC MBh	TC MBh	SHC MBh	TC MBh	SHC MBh	TC MBh	SHC MBh	TC MBh	SHC MBh	TC MBh	SHC MBh
ARNU123TRD4 / 12.3	-9.9	8.1	6.8	9.8	7.9	11.1	8.4	12.3	8.9	13.8	9.6	14.7	9.5	15.9	9.5
	-5	8.1	6.8	9.8	7.9	11.1	8.4	12.3	8.9	13.8	9.6	14.7	9.5	15.9	9.5
	0	8.1	6.8	9.8	7.9	11.1	8.4	12.3	8.9	13.8	9.6	14.7	9.5	15.9	9.5
	5	8.1	6.8	9.8	7.9	11.1	8.4	12.3	8.9	13.8	9.6	14.7	9.5	15.9	9.5
	10	8.1	6.8	9.8	7.9	11.1	8.4	12.3	8.9	13.8	9.6	14.7	9.5	15.9	9.5
	14	8.1	6.8	9.8	7.9	11.1	8.4	12.3	8.9	13.8	9.6	14.7	9.5	15.9	9.5
	20	8.1	6.8	9.8	7.9	11.1	8.4	12.3	8.9	13.8	9.6	14.7	9.5	15.9	9.5
	23	8.1	6.8	9.8	7.9	11.1	8.4	12.3	8.9	13.8	9.6	14.7	9.5	15.9	9.5
	25	8.1	6.8	9.8	7.9	11.1	8.4	12.3	8.9	13.8	9.6	14.7	9.5	15.9	9.5
	30	8.1	6.8	9.8	7.9	11.1	8.4	12.3	8.9	13.8	9.6	14.7	9.5	15.9	9.5
	35	8.1	6.8	9.8	7.9	11.1	8.4	12.3	8.9	13.8	9.6	14.7	9.5	15.9	9.5
	40	8.1	6.8	9.8	7.9	11.1	8.4	12.3	8.9	13.8	9.6	14.7	9.5	15.9	9.5
	45	8.1	6.8	9.8	7.9	11.1	8.4	12.3	8.9	13.8	9.6	14.7	9.5	15.9	9.5
	50	8.1	6.8	9.8	7.9	11.1	8.4	12.3	8.9	13.8	9.6	14.7	9.5	15.9	9.5
	55	8.1	6.8	9.8	7.9	11.1	8.4	12.3	8.9	13.8	9.6	14.7	9.5	15.9	9.5
	60	8.1	6.8	9.8	7.9	11.1	8.4	12.3	8.9	13.8	9.6	14.7	9.5	15.7	9.4
	65	8.1	6.8	9.8	7.9	11.1	8.4	12.3	8.9	13.8	9.6	14.7	9.5	15.5	9.3
	70	8.1	6.8	9.8	7.9	11.1	8.4	12.3	8.9	13.8	9.6	14.7	9.5	15.3	9.1
	75	8.1	6.8	9.8	7.9	11.1	8.4	12.3	8.9	13.8	9.6	14.7	9.5	14.9	8.9
	80	8.1	6.8	9.8	7.9	11.1	8.4	12.3	8.9	13.8	9.6	14.2	9.4	14.5	8.9
85	8.1	6.8	9.8	7.9	11.1	8.4	12.3	8.9	13.6	9.5	13.8	9.0	14.0	8.5	
90	8.1	6.8	9.8	7.9	11.1	8.4	12.3	8.9	13.4	9.3	13.5	8.9	13.8	8.4	
95	8.1	6.8	9.8	7.9	11.1	8.4	<b>12.3</b>	<b>8.9</b>	13.2	9.3	13.4	8.8	13.6	8.3	
100	8.1	6.8	9.8	7.9	11.1	8.4	12.3	8.9	12.9	9.1	13.2	8.7	13.4	8.3	
105	8.1	6.8	9.3	7.5	10.6	8.0	11.8	8.5	12.3	8.5	12.7	8.4	13.0	8.1	
110	7.9	6.6	8.9	7.1	9.8	7.5	11.1	8.0	11.6	8.0	12.0	8.0	12.6	7.8	
115	7.7	6.4	8.4	6.7	9.2	7.0	10.4	7.6	10.9	7.6	11.4	7.6	12.1	7.5	
118	7.5	6.2	8.0	6.4	8.8	6.6	10.0	7.2	10.4	7.2	10.9	7.2	11.6	7.2	
122	7.3	6.0	7.6	6.0	8.3	6.2	9.4	6.9	9.8	6.9	10.3	6.9	11.1	6.9	
ARNU153TQD4 / 15.4	-9.9	10.1	8.5	12.3	9.8	13.9	10.4	15.4	11.1	17.3	11.9	18.4	11.8	19.9	11.8
	-5	10.1	8.5	12.3	9.8	13.9	10.4	15.4	11.1	17.3	11.9	18.4	11.8	19.9	11.8
	0	10.1	8.5	12.3	9.8	13.9	10.4	15.4	11.1	17.3	11.9	18.4	11.8	19.9	11.8
	5	10.1	8.5	12.3	9.8	13.9	10.4	15.4	11.1	17.3	11.9	18.4	11.8	19.9	11.8
	10	10.1	8.5	12.3	9.8	13.9	10.4	15.4	11.1	17.3	11.9	18.4	11.8	19.9	11.8
	14	10.1	8.5	12.3	9.8	13.9	10.4	15.4	11.1	17.3	11.9	18.4	11.8	19.9	11.8
	20	10.1	8.5	12.3	9.8	13.9	10.4	15.4	11.1	17.3	11.9	18.4	11.8	19.9	11.8
	23	10.1	8.5	12.3	9.8	13.9	10.4	15.4	11.1	17.3	11.9	18.4	11.8	19.9	11.8
	25	10.1	8.5	12.3	9.8	13.9	10.4	15.4	11.1	17.3	11.9	18.4	11.8	19.9	11.8
	30	10.1	8.5	12.3	9.8	13.9	10.4	15.4	11.1	17.3	11.9	18.4	11.8	19.9	11.8
	35	10.1	8.5	12.3	9.8	13.9	10.4	15.4	11.1	17.3	11.9	18.4	11.8	19.9	11.8
	40	10.1	8.5	12.3	9.8	13.9	10.4	15.4	11.1	17.3	11.9	18.4	11.8	19.9	11.8
	45	10.1	8.5	12.3	9.8	13.9	10.4	15.4	11.1	17.3	11.9	18.4	11.8	19.9	11.8
	50	10.1	8.5	12.3	9.8	13.9	10.4	15.4	11.1	17.3	11.9	18.4	11.8	19.9	11.8
	55	10.1	8.5	12.3	9.8	13.9	10.4	15.4	11.1	17.3	11.9	18.4	11.8	19.9	11.8
	60	10.1	8.5	12.3	9.8	13.9	10.4	15.4	11.1	17.3	11.9	18.4	11.8	19.7	11.7
	65	10.1	8.5	12.3	9.8	13.9	10.4	15.4	11.1	17.3	11.9	18.4	11.8	19.4	11.5
	70	10.1	8.5	12.3	9.8	13.9	10.4	15.4	11.1	17.3	11.9	18.4	11.8	19.1	11.4
	75	10.1	8.5	12.3	9.8	13.9	10.4	15.4	11.1	17.3	11.9	18.4	11.8	18.6	11.1
	80	10.1	8.5	12.3	9.8	13.9	10.4	15.4	11.1	17.3	11.9	17.8	11.7	18.2	11.0
85	10.1	8.5	12.3	9.8	13.9	10.4	15.4	11.1	17.1	11.8	17.3	11.2	17.6	10.6	
90	10.1	8.5	12.3	9.8	13.9	10.4	15.4	11.1	16.8	11.6	16.9	11.0	17.3	10.5	
95	10.1	8.5	12.3	9.8	13.9	10.4	<b>15.4</b>	<b>11.1</b>	16.5	11.5	16.8	11.0	17.1	10.4	
100	10.1	8.5	12.3	9.8	13.9	10.4	15.4	11.1	16.2	11.4	16.5	10.9	16.8	10.3	
105	10.1	8.5	11.7	9.3	13.2	10.0	14.8	10.6	15.4	10.6	15.8	10.5	16.3	10.0	
110	9.9	8.2	11.1	8.8	12.3	9.3	13.9	10.0	14.5	10.0	15.1	10.0	15.7	9.7	
115	9.6	8.0	10.5	8.3	11.6	8.7	13.0	9.5	13.6	9.5	14.3	9.5	15.1	9.3	
118	9.4	7.8	10.0	7.9	11.0	8.2	12.5	9.0	13.0	9.0	13.7	9.0	14.5	9.0	
122	9.1	7.5	9.5	7.5	10.4	7.7	11.8	8.5	12.3	8.5	12.9	8.5	13.9	8.5	

TC: Total Capacity (MBh); SHC: Sensible Heat Capacity (MBh).

The System Combination Ratio must be between 50-130%.

Rated capacity is certified under AHRI Standard 1230. Ratings are subject to change without notice.

Current certified ratings are available at [www.ahridirectory.org](http://www.ahridirectory.org).

For outdoor unit performance data, see the respective outdoor unit performance data manuals on [www.lghvac.com](http://www.lghvac.com).

Low ambient performance with LGRED® heat technology is included in Multi V 5 air source units produced after February 2019.

Due to our policy of continuous product innovation, some specifications may change without notification.

© LG Electronics U.S.A., Inc., Englewood Cliffs, NJ. All rights reserved. "LG" is a registered trademark of LG Corp.

Table 43: ARNU183TQD4 Cooling Capacity Table.

Model No. / Capacity Index	Outdoor Air Temp. (°F DB)	Indoor Air Temperature (°F DB / WB)													
		68 / 57		73 / 61		79 / 64		80 / 67		85 / 70		88 / 73		91 / 76	
		TC MBh	SHC MBh	TC MBh	SHC MBh	TC MBh	SHC MBh	TC MBh	SHC MBh	TC MBh	SHC MBh	TC MBh	SHC MBh	TC MBh	SHC MBh
ARNU183TQD4 / 19.1	-9.9	12.6	10.6	15.3	12.2	17.2	13.0	19.1	13.8	21.4	14.8	22.8	14.7	24.7	14.7
	-5	12.6	10.6	15.3	12.2	17.2	13.0	19.1	13.8	21.4	14.8	22.8	14.7	24.7	14.7
	0	12.6	10.6	15.3	12.2	17.2	13.0	19.1	13.8	21.4	14.8	22.8	14.7	24.7	14.7
	5	12.6	10.6	15.3	12.2	17.2	13.0	19.1	13.8	21.4	14.8	22.8	14.7	24.7	14.7
	10	12.6	10.6	15.3	12.2	17.2	13.0	19.1	13.8	21.4	14.8	22.8	14.7	24.7	14.7
	14	12.6	10.6	15.3	12.2	17.2	13.0	19.1	13.8	21.4	14.8	22.8	14.7	24.7	14.7
	20	12.6	10.6	15.3	12.2	17.2	13.0	19.1	13.8	21.4	14.8	22.8	14.7	24.7	14.7
	23	12.6	10.6	15.3	12.2	17.2	13.0	19.1	13.8	21.4	14.8	22.8	14.7	24.7	14.7
	25	12.6	10.6	15.3	12.2	17.2	13.0	19.1	13.8	21.4	14.8	22.8	14.7	24.7	14.7
	30	12.6	10.6	15.3	12.2	17.2	13.0	19.1	13.8	21.4	14.8	22.8	14.7	24.7	14.7
	35	12.6	10.6	15.3	12.2	17.2	13.0	19.1	13.8	21.4	14.8	22.8	14.7	24.7	14.7
	40	12.6	10.6	15.3	12.2	17.2	13.0	19.1	13.8	21.4	14.8	22.8	14.7	24.7	14.7
	45	12.6	10.6	15.3	12.2	17.2	13.0	19.1	13.8	21.4	14.8	22.8	14.7	24.7	14.7
	50	12.6	10.6	15.3	12.2	17.2	13.0	19.1	13.8	21.4	14.8	22.8	14.7	24.7	14.7
	55	12.6	10.6	15.3	12.2	17.2	13.0	19.1	13.8	21.4	14.8	22.8	14.7	24.7	14.7
	60	12.6	10.6	15.3	12.2	17.2	13.0	19.1	13.8	21.4	14.8	22.8	14.7	24.4	14.6
	65	12.6	10.6	15.3	12.2	17.2	13.0	19.1	13.8	21.4	14.8	22.8	14.7	24.0	14.4
	70	12.6	10.6	15.3	12.2	17.2	13.0	19.1	13.8	21.4	14.8	22.8	14.7	23.7	14.1
	75	12.6	10.6	15.3	12.2	17.2	13.0	19.1	13.8	21.4	14.8	22.8	14.7	23.1	13.8
	80	12.6	10.6	15.3	12.2	17.2	13.0	19.1	13.8	21.4	14.8	22.1	14.6	22.5	13.7
85	12.6	10.6	15.3	12.2	17.2	13.0	19.1	13.8	21.2	14.7	21.4	14.0	21.8	13.2	
90	12.6	10.6	15.3	12.2	17.2	13.0	19.1	13.8	20.9	14.4	21.0	13.7	21.4	13.0	
95	12.6	10.6	15.3	12.2	17.2	13.0	<b>19.1</b>	<b>13.8</b>	20.5	14.4	20.9	13.7	21.2	12.9	
100	12.6	10.6	15.3	12.2	17.2	13.0	19.1	13.8	20.1	14.1	20.5	13.5	20.9	12.8	
105	12.6	10.6	14.5	11.6	16.4	12.4	18.3	13.2	19.0	13.2	19.7	13.0	20.2	12.5	
110	12.3	10.2	13.8	10.9	15.3	11.6	17.2	12.4	18.0	12.4	18.7	12.4	19.5	12.1	
115	12.0	9.9	13.1	10.4	14.4	10.9	16.2	11.8	16.9	11.8	17.8	11.8	18.7	11.6	
118	11.7	9.6	12.4	9.9	13.6	10.2	15.5	11.2	16.1	11.2	17.0	11.2	18.0	11.1	
122	11.3	9.3	11.8	9.4	12.9	9.6	14.7	10.6	15.3	10.6	16.0	10.6	17.2	10.6	

TC: Total Capacity (MBh); SHC: Sensible Heat Capacity (MBh).  
 The System Combination Ratio must be between 50–130%.  
 Rated capacity is certified under AHRI Standard 1230. Ratings are subject to change without notice.  
 Current certified ratings are available at [www.ahridirectory.org](http://www.ahridirectory.org).

For outdoor unit performance data, see the respective outdoor unit performance data manuals on [www.lghvac.com](http://www.lghvac.com).  
 Low ambient performance with LGRED® heat technology is included in Multi V 5 air source units produced after February 2019.

# FOUR-WAY CEILING CASSETTE



## Cooling Capacity Tables

### ARNU073TNA4, ARNU093TNA4

Table 44: ARNU073TNA4, ARNU093TNA4 Cooling Capacity Table.

Model No. / Capacity Index	Outdoor Air Temp. (°F DB)	Indoor Air Temperature (°F DB / WB)													
		68 / 57		73 / 61		79 / 64		80 / 67		85 / 70		88 / 73		91 / 76	
		TC MBh	SHC MBh	TC MBh	SHC MBh	TC MBh	SHC MBh	TC MBh	SHC MBh	TC MBh	SHC MBh	TC MBh	SHC MBh	TC MBh	SHC MBh
ARNU073TNA4 / 7.5	-9.9	4.9	4.3	6.0	4.9	6.8	5.3	7.5	5.6	8.4	6.0	8.9	5.9	9.7	5.9
	-5	4.9	4.3	6.0	4.9	6.8	5.3	7.5	5.6	8.4	6.0	8.9	5.9	9.7	5.9
	0	4.9	4.3	6.0	4.9	6.8	5.3	7.5	5.6	8.4	6.0	8.9	5.9	9.7	5.9
	5	4.9	4.3	6.0	4.9	6.8	5.3	7.5	5.6	8.4	6.0	8.9	5.9	9.7	5.9
	10	4.9	4.3	6.0	4.9	6.8	5.3	7.5	5.6	8.4	6.0	8.9	5.9	9.7	5.9
	14	4.9	4.3	6.0	4.9	6.8	5.3	7.5	5.6	8.4	6.0	8.9	5.9	9.7	5.9
	20	4.9	4.3	6.0	4.9	6.8	5.3	7.5	5.6	8.4	6.0	8.9	5.9	9.7	5.9
	23	4.9	4.3	6.0	4.9	6.8	5.3	7.5	5.6	8.4	6.0	8.9	5.9	9.7	5.9
	25	4.9	4.3	6.0	4.9	6.8	5.3	7.5	5.6	8.4	6.0	8.9	5.9	9.7	5.9
	30	4.9	4.3	6.0	4.9	6.8	5.3	7.5	5.6	8.4	6.0	8.9	5.9	9.7	5.9
	35	4.9	4.3	6.0	4.9	6.8	5.3	7.5	5.6	8.4	6.0	8.9	5.9	9.7	5.9
	40	4.9	4.3	6.0	4.9	6.8	5.3	7.5	5.6	8.4	6.0	8.9	5.9	9.7	5.9
	45	4.9	4.3	6.0	4.9	6.8	5.3	7.5	5.6	8.4	6.0	8.9	5.9	9.7	5.9
	50	4.9	4.3	6.0	4.9	6.8	5.3	7.5	5.6	8.4	6.0	8.9	5.9	9.7	5.9
	55	4.9	4.3	6.0	4.9	6.8	5.3	7.5	5.6	8.4	6.0	8.9	5.9	9.7	5.9
	60	4.9	4.3	6.0	4.9	6.8	5.3	7.5	5.6	8.4	6.0	8.9	5.9	9.6	5.9
	65	4.9	4.3	6.0	4.9	6.8	5.3	7.5	5.6	8.4	6.0	8.9	5.9	9.4	5.8
	70	4.9	4.3	6.0	4.9	6.8	5.3	7.5	5.6	8.4	6.0	8.9	5.9	9.3	5.7
	75	4.9	4.3	6.0	4.9	6.8	5.3	7.5	5.6	8.4	6.0	8.9	5.9	9.1	5.6
	80	4.9	4.3	6.0	4.9	6.8	5.3	7.5	5.6	8.4	6.0	8.7	5.9	8.8	5.6
	85	4.9	4.3	6.0	4.9	6.8	5.3	7.5	5.6	8.3	5.9	8.4	5.7	8.6	5.4
90	4.9	4.3	6.0	4.9	6.8	5.3	7.5	5.6	8.2	5.9	8.3	5.6	8.4	5.3	
95	4.9	4.3	6.0	4.9	6.8	5.3	7.5	5.6	8.0	5.8	8.2	5.5	8.3	5.2	
100	4.9	4.3	6.0	4.9	6.8	5.3	7.5	5.6	7.9	5.7	8.0	5.5	8.2	5.2	
105	4.9	4.3	5.7	4.7	6.4	5.0	7.2	5.4	7.5	5.4	7.7	5.3	7.9	5.1	
110	4.8	4.2	5.4	4.4	6.0	4.7	6.8	5.0	7.1	5.0	7.3	5.0	7.7	4.9	
115	4.7	4.0	5.1	4.2	5.6	4.4	6.3	4.8	6.6	4.8	7.0	4.8	7.4	4.7	
118	4.6	3.9	4.9	4.0	5.4	4.1	6.1	4.5	6.3	4.5	6.7	4.5	7.1	4.5	
122	4.5	3.8	4.6	3.8	5.1	3.9	5.8	4.3	6.0	4.3	6.3	4.3	6.8	4.3	
ARNU093TNA4 / 9.6	-9.9	6.3	5.4	7.7	6.3	8.6	6.7	9.6	7.1	10.8	7.6	11.4	7.5	12.4	7.5
	-5	6.3	5.4	7.7	6.3	8.6	6.7	9.6	7.1	10.8	7.6	11.4	7.5	12.4	7.5
	0	6.3	5.4	7.7	6.3	8.6	6.7	9.6	7.1	10.8	7.6	11.4	7.5	12.4	7.5
	5	6.3	5.4	7.7	6.3	8.6	6.7	9.6	7.1	10.8	7.6	11.4	7.5	12.4	7.5
	10	6.3	5.4	7.7	6.3	8.6	6.7	9.6	7.1	10.8	7.6	11.4	7.5	12.4	7.5
	14	6.3	5.4	7.7	6.3	8.6	6.7	9.6	7.1	10.8	7.6	11.4	7.5	12.4	7.5
	20	6.3	5.4	7.7	6.3	8.6	6.7	9.6	7.1	10.8	7.6	11.4	7.5	12.4	7.5
	23	6.3	5.4	7.7	6.3	8.6	6.7	9.6	7.1	10.8	7.6	11.4	7.5	12.4	7.5
	25	6.3	5.4	7.7	6.3	8.6	6.7	9.6	7.1	10.8	7.6	11.4	7.5	12.4	7.5
	30	6.3	5.4	7.7	6.3	8.6	6.7	9.6	7.1	10.8	7.6	11.4	7.5	12.4	7.5
	35	6.3	5.4	7.7	6.3	8.6	6.7	9.6	7.1	10.8	7.6	11.4	7.5	12.4	7.5
	40	6.3	5.4	7.7	6.3	8.6	6.7	9.6	7.1	10.8	7.6	11.4	7.5	12.4	7.5
	45	6.3	5.4	7.7	6.3	8.6	6.7	9.6	7.1	10.8	7.6	11.4	7.5	12.4	7.5
	50	6.3	5.4	7.7	6.3	8.6	6.7	9.6	7.1	10.8	7.6	11.4	7.5	12.4	7.5
	55	6.3	5.4	7.7	6.3	8.6	6.7	9.6	7.1	10.8	7.6	11.4	7.5	12.4	7.5
	60	6.3	5.4	7.7	6.3	8.6	6.7	9.6	7.1	10.8	7.6	11.4	7.5	12.3	7.5
	65	6.3	5.4	7.7	6.3	8.6	6.7	9.6	7.1	10.8	7.6	11.4	7.5	12.1	7.4
	70	6.3	5.4	7.7	6.3	8.6	6.7	9.6	7.1	10.8	7.6	11.4	7.5	11.9	7.3
	75	6.3	5.4	7.7	6.3	8.6	6.7	9.6	7.1	10.8	7.6	11.4	7.5	11.6	7.1
	80	6.3	5.4	7.7	6.3	8.6	6.7	9.6	7.1	10.8	7.6	11.1	7.5	11.3	7.1
	85	6.3	5.4	7.7	6.3	8.6	6.7	9.6	7.1	10.6	7.5	10.8	7.2	11.0	6.8
90	6.3	5.4	7.7	6.3	8.6	6.7	9.6	7.1	10.5	7.4	10.6	7.1	10.8	6.7	
95	6.3	5.4	7.7	6.3	8.6	6.7	9.6	7.1	10.3	7.4	10.5	7.0	10.6	6.6	
100	6.3	5.4	7.7	6.3	8.6	6.7	9.6	7.1	10.1	7.3	10.3	6.9	10.5	6.6	
105	6.3	5.4	7.3	5.9	8.2	6.4	9.2	6.8	9.6	6.8	9.9	6.7	10.2	6.4	
110	6.2	5.3	6.9	5.6	7.7	5.9	8.6	6.4	9.0	6.4	9.4	6.4	9.8	6.2	
115	6.0	5.1	6.6	5.3	7.2	5.6	8.1	6.1	8.5	6.1	8.9	6.1	9.4	6.0	
118	5.9	5.0	6.2	5.1	6.9	5.3	7.8	5.8	8.1	5.8	8.5	5.8	9.0	5.7	
122	5.7	4.8	5.9	4.8	6.5	4.9	7.4	5.5	7.7	5.5	8.1	5.5	8.7	5.5	

TC: Total Capacity (MBh); SHC: Sensible Heat Capacity (MBh).

The System Combination Ratio must be between 50-130%.

Rated capacity is certified under AHRI Standard 1230. Ratings are subject to change without notice.

Current certified ratings are available at [www.ahrirectory.org](http://www.ahrirectory.org).

For outdoor unit performance data, see the respective outdoor unit performance data manuals on [www.lg hvac.com](http://www.lg hvac.com).

Low ambient performance with LGRED® heat technology is included in Multi V 5 air source units produced after February 2019.

Due to our policy of continuous product innovation, some specifications may change without notification.

© LG Electronics U.S.A., Inc., Englewood Cliffs, NJ. All rights reserved. "LG" is a registered trademark of LG Corp.





Table 45: ARNU123TNA4 Cooling Capacity Table.

Model No. / Capacity Index	Outdoor Air Temp. (°F DB)	Indoor Air Temperature (°F DB / WB)													
		68 / 57		73 / 61		79 / 64		80 / 67		85 / 70		88 / 73		91 / 76	
		TC MBh	SHC MBh	TC MBh	SHC MBh	TC MBh	SHC MBh	TC MBh	SHC MBh	TC MBh	SHC MBh	TC MBh	SHC MBh	TC MBh	SHC MBh
ARNU123TNA4 / 12.3	-9.9	8.1	7.0	9.8	8.0	11.1	8.5	12.3	9.1	13.8	9.8	14.7	9.7	15.9	9.7
	-5	8.1	7.0	9.8	8.0	11.1	8.5	12.3	9.1	13.8	9.8	14.7	9.7	15.9	9.7
	0	8.1	7.0	9.8	8.0	11.1	8.5	12.3	9.1	13.8	9.8	14.7	9.7	15.9	9.7
	5	8.1	7.0	9.8	8.0	11.1	8.5	12.3	9.1	13.8	9.8	14.7	9.7	15.9	9.7
	10	8.1	7.0	9.8	8.0	11.1	8.5	12.3	9.1	13.8	9.8	14.7	9.7	15.9	9.7
	14	8.1	7.0	9.8	8.0	11.1	8.5	12.3	9.1	13.8	9.8	14.7	9.7	15.9	9.7
	20	8.1	7.0	9.8	8.0	11.1	8.5	12.3	9.1	13.8	9.8	14.7	9.7	15.9	9.7
	23	8.1	7.0	9.8	8.0	11.1	8.5	12.3	9.1	13.8	9.8	14.7	9.7	15.9	9.7
	25	8.1	7.0	9.8	8.0	11.1	8.5	12.3	9.1	13.8	9.8	14.7	9.7	15.9	9.7
	30	8.1	7.0	9.8	8.0	11.1	8.5	12.3	9.1	13.8	9.8	14.7	9.7	15.9	9.7
	35	8.1	7.0	9.8	8.0	11.1	8.5	12.3	9.1	13.8	9.8	14.7	9.7	15.9	9.7
	40	8.1	7.0	9.8	8.0	11.1	8.5	12.3	9.1	13.8	9.8	14.7	9.7	15.9	9.7
	45	8.1	7.0	9.8	8.0	11.1	8.5	12.3	9.1	13.8	9.8	14.7	9.7	15.9	9.7
	50	8.1	7.0	9.8	8.0	11.1	8.5	12.3	9.1	13.8	9.8	14.7	9.7	15.9	9.7
	55	8.1	7.0	9.8	8.0	11.1	8.5	12.3	9.1	13.8	9.8	14.7	9.7	15.9	9.7
	60	8.1	7.0	9.8	8.0	11.1	8.5	12.3	9.1	13.8	9.8	14.7	9.7	15.7	9.6
	65	8.1	7.0	9.8	8.0	11.1	8.5	12.3	9.1	13.8	9.8	14.7	9.7	15.5	9.5
	70	8.1	7.0	9.8	8.0	11.1	8.5	12.3	9.1	13.8	9.8	14.7	9.7	15.3	9.3
	75	8.1	7.0	9.8	8.0	11.1	8.5	12.3	9.1	13.8	9.8	14.7	9.7	14.9	9.1
	80	8.1	7.0	9.8	8.0	11.1	8.5	12.3	9.1	13.8	9.8	14.2	9.6	14.5	9.1
85	8.1	7.0	9.8	8.0	11.1	8.5	12.3	9.1	13.6	9.7	13.8	9.2	14.0	8.7	
90	8.1	7.0	9.8	8.0	11.1	8.5	12.3	9.1	13.4	9.5	13.5	9.1	13.8	8.6	
95	8.1	7.0	9.8	8.0	11.1	8.5	12.3	<b>12.3</b>	<b>9.1</b>	13.2	9.5	13.4	9.0	13.6	8.5
100	8.1	7.0	9.8	8.0	11.1	8.5	12.3	9.1	12.9	9.3	13.2	8.9	13.4	8.4	
105	8.1	7.0	9.3	7.6	10.6	8.2	11.8	8.7	12.3	8.7	12.7	8.6	13.0	8.2	
110	7.9	6.7	8.9	7.2	9.8	7.6	11.1	8.2	11.6	8.2	12.0	8.2	12.6	8.0	
115	7.7	6.6	8.4	6.8	9.2	7.2	10.4	7.8	10.9	7.8	11.4	7.8	12.1	7.7	
118	7.5	6.4	8.0	6.5	8.8	6.7	10.0	7.4	10.4	7.4	10.9	7.4	11.6	7.3	
122	7.3	6.2	7.6	6.2	8.3	6.3	9.4	7.0	9.8	7.0	10.3	7.0	11.1	7.0	

TC: Total Capacity (MBh); SHC: Sensible Heat Capacity (MBh).

The System Combination Ratio must be between 50–130%.

Rated capacity is certified under AHRI Standard 1230. Ratings are subject to change without notice. Current certified ratings are available at [www.ahridirectory.org](http://www.ahridirectory.org).

For outdoor unit performance data, see the respective outdoor unit performance data manuals on [www.lghvac.com](http://www.lghvac.com).

Low ambient performance with LGRED® heat technology is included in Multi V 5 air source units produced after February 2019.

# FOUR-WAY CEILING CASSETTE



## Cooling Capacity Tables

### ARNU153TNA4, ARNU183TNA4

Table 46: ARNU153TNA4, ARNU183TNA4, ARNU243TNA4 Cooling Capacity Table.

Model No. / Capacity Index	Outdoor Air Temp. (°F DB)	Indoor Air Temperature (°F DB / WB)													
		68 / 57		73 / 61		79 / 64		80 / 67		85 / 70		88 / 73		91 / 76	
		TC MBh	SHC MBh	TC MBh	SHC MBh	TC MBh	SHC MBh	TC MBh	SHC MBh	TC MBh	SHC MBh	TC MBh	SHC MBh	TC MBh	SHC MBh
ARNU153TNA4 / 15.4	-9.9	10.1	8.7	12.3	10.1	13.9	10.7	15.4	11.4	17.3	12.2	18.4	12.1	19.9	12.1
	-5	10.1	8.7	12.3	10.1	13.9	10.7	15.4	11.4	17.3	12.2	18.4	12.1	19.9	12.1
	0	10.1	8.7	12.3	10.1	13.9	10.7	15.4	11.4	17.3	12.2	18.4	12.1	19.9	12.1
	5	10.1	8.7	12.3	10.1	13.9	10.7	15.4	11.4	17.3	12.2	18.4	12.1	19.9	12.1
	10	10.1	8.7	12.3	10.1	13.9	10.7	15.4	11.4	17.3	12.2	18.4	12.1	19.9	12.1
	14	10.1	8.7	12.3	10.1	13.9	10.7	15.4	11.4	17.3	12.2	18.4	12.1	19.9	12.1
	20	10.1	8.7	12.3	10.1	13.9	10.7	15.4	11.4	17.3	12.2	18.4	12.1	19.9	12.1
	23	10.1	8.7	12.3	10.1	13.9	10.7	15.4	11.4	17.3	12.2	18.4	12.1	19.9	12.1
	25	10.1	8.7	12.3	10.1	13.9	10.7	15.4	11.4	17.3	12.2	18.4	12.1	19.9	12.1
	30	10.1	8.7	12.3	10.1	13.9	10.7	15.4	11.4	17.3	12.2	18.4	12.1	19.9	12.1
	35	10.1	8.7	12.3	10.1	13.9	10.7	15.4	11.4	17.3	12.2	18.4	12.1	19.9	12.1
	40	10.1	8.7	12.3	10.1	13.9	10.7	15.4	11.4	17.3	12.2	18.4	12.1	19.9	12.1
	45	10.1	8.7	12.3	10.1	13.9	10.7	15.4	11.4	17.3	12.2	18.4	12.1	19.9	12.1
	50	10.1	8.7	12.3	10.1	13.9	10.7	15.4	11.4	17.3	12.2	18.4	12.1	19.9	12.1
	55	10.1	8.7	12.3	10.1	13.9	10.7	15.4	11.4	17.3	12.2	18.4	12.1	19.9	12.1
	60	10.1	8.7	12.3	10.1	13.9	10.7	15.4	11.4	17.3	12.2	18.4	12.1	19.9	12.1
	65	10.1	8.7	12.3	10.1	13.9	10.7	15.4	11.4	17.3	12.2	18.4	12.1	19.9	12.1
	70	10.1	8.7	12.3	10.1	13.9	10.7	15.4	11.4	17.3	12.2	18.4	12.1	19.9	12.1
	75	10.1	8.7	12.3	10.1	13.9	10.7	15.4	11.4	17.3	12.2	18.4	12.1	19.9	12.1
	80	10.1	8.7	12.3	10.1	13.9	10.7	15.4	11.4	17.3	12.2	18.4	12.1	19.9	12.1
	85	10.1	8.7	12.3	10.1	13.9	10.7	15.4	11.4	17.3	12.2	18.4	12.1	19.9	12.1
	90	10.1	8.7	12.3	10.1	13.9	10.7	15.4	11.4	17.3	12.2	18.4	12.1	19.9	12.1
	95	10.1	8.7	12.3	10.1	13.9	10.7	<b>15.4</b>	<b>11.4</b>	16.5	11.8	16.8	11.3	17.1	10.6
100	10.1	8.7	12.3	10.1	13.9	10.7	15.4	11.4	16.2	11.7	16.5	11.1	16.8	10.6	
105	10.1	8.7	11.7	9.5	13.2	10.2	14.8	10.9	15.4	10.9	15.8	10.8	16.3	10.3	
110	9.9	8.5	11.1	9.0	12.3	9.5	13.9	10.2	14.5	10.2	15.1	10.2	15.7	10.0	
115	9.6	8.2	10.5	8.6	11.6	9.0	13.0	9.7	13.6	9.7	14.3	9.7	15.1	9.6	
118	9.4	8.0	10.0	8.1	11.0	8.4	12.5	9.2	13.0	9.2	13.7	9.2	14.5	9.2	
122	9.1	7.7	9.5	7.7	10.4	7.9	11.8	8.8	12.3	8.8	12.9	8.8	13.9	8.8	
ARNU183TNA4 / 19.1	-9.9	12.6	11.7	15.3	13.5	17.2	14.4	19.1	15.3	21.4	16.4	22.8	16.2	24.7	16.2
	-5	12.6	11.7	15.3	13.5	17.2	14.4	19.1	15.3	21.4	16.4	22.8	16.2	24.7	16.2
	0	12.6	11.7	15.3	13.5	17.2	14.4	19.1	15.3	21.4	16.4	22.8	16.2	24.7	16.2
	5	12.6	11.7	15.3	13.5	17.2	14.4	19.1	15.3	21.4	16.4	22.8	16.2	24.7	16.2
	10	12.6	11.7	15.3	13.5	17.2	14.4	19.1	15.3	21.4	16.4	22.8	16.2	24.7	16.2
	14	12.6	11.7	15.3	13.5	17.2	14.4	19.1	15.3	21.4	16.4	22.8	16.2	24.7	16.2
	20	12.6	11.7	15.3	13.5	17.2	14.4	19.1	15.3	21.4	16.4	22.8	16.2	24.7	16.2
	23	12.6	11.7	15.3	13.5	17.2	14.4	19.1	15.3	21.4	16.4	22.8	16.2	24.7	16.2
	25	12.6	11.7	15.3	13.5	17.2	14.4	19.1	15.3	21.4	16.4	22.8	16.2	24.7	16.2
	30	12.6	11.7	15.3	13.5	17.2	14.4	19.1	15.3	21.4	16.4	22.8	16.2	24.7	16.2
	35	12.6	11.7	15.3	13.5	17.2	14.4	19.1	15.3	21.4	16.4	22.8	16.2	24.7	16.2
	40	12.6	11.7	15.3	13.5	17.2	14.4	19.1	15.3	21.4	16.4	22.8	16.2	24.7	16.2
	45	12.6	11.7	15.3	13.5	17.2	14.4	19.1	15.3	21.4	16.4	22.8	16.2	24.7	16.2
	50	12.6	11.7	15.3	13.5	17.2	14.4	19.1	15.3	21.4	16.4	22.8	16.2	24.7	16.2
	55	12.6	11.7	15.3	13.5	17.2	14.4	19.1	15.3	21.4	16.4	22.8	16.2	24.7	16.2
	60	12.6	11.7	15.3	13.5	17.2	14.4	19.1	15.3	21.4	16.4	22.8	16.2	24.4	16.2
	65	12.6	11.7	15.3	13.5	17.2	14.4	19.1	15.3	21.4	16.4	22.8	16.2	24.0	15.9
	70	12.6	11.7	15.3	13.5	17.2	14.4	19.1	15.3	21.4	16.4	22.8	16.2	23.7	15.6
	75	12.6	11.7	15.3	13.5	17.2	14.4	19.1	15.3	21.4	16.4	22.8	16.2	23.1	15.3
	80	12.6	11.7	15.3	13.5	17.2	14.4	19.1	15.3	21.4	16.4	22.1	16.2	22.5	15.2
	85	12.6	11.7	15.3	13.5	17.2	14.4	19.1	15.3	21.2	16.2	21.4	15.5	21.8	14.6
	90	12.6	11.7	15.3	13.5	17.2	14.4	19.1	15.3	20.9	16.0	21.0	15.2	21.4	14.4
	95	12.6	11.7	15.3	13.5	17.2	14.4	<b>19.1</b>	<b>15.3</b>	20.5	15.9	20.9	15.1	21.2	14.3
100	12.6	11.7	15.3	13.5	17.2	14.4	19.1	15.3	20.1	15.6	20.5	15.0	20.9	14.2	
105	12.6	11.7	14.5	12.8	16.4	13.8	18.3	14.6	19.0	14.6	19.7	14.4	20.2	13.8	
110	12.3	11.3	13.8	12.1	15.3	12.8	17.2	13.8	18.0	13.8	18.7	13.8	19.5	13.4	
115	12.0	11.0	13.1	11.5	14.4	12.0	16.2	13.1	16.9	13.1	17.8	13.1	18.7	12.9	
118	11.7	10.7	12.4	10.9	13.6	11.3	15.5	12.4	16.1	12.4	17.0	12.4	18.0	12.3	
122	11.3	10.3	11.8	10.4	12.9	10.6	14.7	11.8	15.3	11.8	16.0	11.8	17.2	11.8	

TC: Total Capacity (MBh); SHC: Sensible Heat Capacity (MBh).

The System Combination Ratio must be between 50–130%.

Rated capacity is certified under AHRI Standard 1230. Ratings are subject to change without notice.

Current certified ratings are available at [www.ahridirectory.org](http://www.ahridirectory.org).

For outdoor unit performance data, see the respective outdoor unit performance data manuals on [www.lghvac.com](http://www.lghvac.com).

Low ambient performance with LGRED® heat technology is included in Multi V 5 air source units produced after February 2019.

Due to our policy of continuous product innovation, some specifications may change without notification.

© LG Electronics U.S.A., Inc., Englewood Cliffs, NJ. All rights reserved. "LG" is a registered trademark of LG Corp.



Table 47: ARNU243TNA4 Cooling Capacity Table.

Model No. / Capacity Index	Outdoor Air Temp. (°F DB)	Indoor Air Temperature (°F DB / WB)													
		68 / 57		73 / 61		79 / 64		80 / 67		85 / 70		88 / 73		91 / 76	
		TC MBh	SHC MBh	TC MBh	SHC MBh	TC MBh	SHC MBh	TC MBh	SHC MBh	TC MBh	SHC MBh	TC MBh	SHC MBh	TC MBh	SHC MBh
ARNU243TNA4 / 24.2	-9.9	15.9	15.0	19.4	17.3	21.8	18.4	24.2	19.6	27.1	21.0	28.8	20.8	31.3	20.8
	-5	15.9	15.0	19.4	17.3	21.8	18.4	24.2	19.6	27.1	21.0	28.8	20.8	31.3	20.8
	0	15.9	15.0	19.4	17.3	21.8	18.4	24.2	19.6	27.1	21.0	28.8	20.8	31.3	20.8
	5	15.9	15.0	19.4	17.3	21.8	18.4	24.2	19.6	27.1	21.0	28.8	20.8	31.3	20.8
	10	15.9	15.0	19.4	17.3	21.8	18.4	24.2	19.6	27.1	21.0	28.8	20.8	31.3	20.8
	14	15.9	15.0	19.4	17.3	21.8	18.4	24.2	19.6	27.1	21.0	28.8	20.8	31.3	20.8
	20	15.9	15.0	19.4	17.3	21.8	18.4	24.2	19.6	27.1	21.0	28.8	20.8	31.3	20.8
	23	15.9	15.0	19.4	17.3	21.8	18.4	24.2	19.6	27.1	21.0	28.8	20.8	31.3	20.8
	25	15.9	15.0	19.4	17.3	21.8	18.4	24.2	19.6	27.1	21.0	28.8	20.8	31.3	20.8
	30	15.9	15.0	19.4	17.3	21.8	18.4	24.2	19.6	27.1	21.0	28.8	20.8	31.3	20.8
	35	15.9	15.0	19.4	17.3	21.8	18.4	24.2	19.6	27.1	21.0	28.8	20.8	31.3	20.8
	40	15.9	15.0	19.4	17.3	21.8	18.4	24.2	19.6	27.1	21.0	28.8	20.8	31.3	20.8
	45	15.9	15.0	19.4	17.3	21.8	18.4	24.2	19.6	27.1	21.0	28.8	20.8	31.3	20.8
	50	15.9	15.0	19.4	17.3	21.8	18.4	24.2	19.6	27.1	21.0	28.8	20.8	31.3	20.8
	55	15.9	15.0	19.4	17.3	21.8	18.4	24.2	19.6	27.1	21.0	28.8	20.8	31.3	20.8
	60	15.9	15.0	19.4	17.3	21.8	18.4	24.2	19.6	27.1	21.0	28.8	20.8	31.0	20.7
	65	15.9	15.0	19.4	17.3	21.8	18.4	24.2	19.6	27.1	21.0	28.8	20.8	30.5	20.4
	70	15.9	15.0	19.4	17.3	21.8	18.4	24.2	19.6	27.1	21.0	28.8	20.8	30.0	20.0
	75	15.9	15.0	19.4	17.3	21.8	18.4	24.2	19.6	27.1	21.0	28.8	20.8	29.2	19.6
	80	15.9	15.0	19.4	17.3	21.8	18.4	24.2	19.6	27.1	21.0	28.0	20.7	28.5	19.5
	85	15.9	15.0	19.4	17.3	21.8	18.4	24.2	19.6	26.8	20.8	27.1	19.8	27.6	18.7
90	15.9	15.0	19.4	17.3	21.8	18.4	24.2	19.6	26.4	20.5	26.6	19.5	27.1	18.5	
95	15.9	15.0	19.4	17.3	21.8	18.4	<b>24.2</b>	<b>19.6</b>	25.9	20.4	26.4	19.4	26.8	18.3	
100	15.9	15.0	19.4	17.3	21.8	18.4	24.2	19.6	25.4	20.0	25.9	19.2	26.4	18.2	
105	15.9	15.0	18.4	16.4	20.8	17.6	23.2	18.7	24.1	18.7	24.9	18.5	25.6	17.7	
110	15.5	14.5	17.4	15.5	19.4	16.4	21.8	17.6	22.8	17.6	23.7	17.6	24.7	17.2	
115	15.1	14.1	16.6	14.7	18.2	15.4	20.5	16.7	21.4	16.7	22.5	16.7	23.7	16.5	
118	14.8	13.7	15.7	14.0	17.3	14.5	19.7	15.9	20.4	15.9	21.5	15.9	22.8	15.8	
122	14.4	13.3	15.0	13.3	16.3	13.6	18.6	15.1	19.4	15.1	20.3	15.1	21.9	15.1	

TC: Total Capacity (MBh); SHC: Sensible Heat Capacity (MBh).  
 The System Combination Ratio must be between 50–130%.  
 Rated capacity is certified under AHRI Standard 1230. Ratings are subject to change without notice.  
 Current certified ratings are available at [www.ahridirectory.org](http://www.ahridirectory.org).

For outdoor unit performance data, see the respective outdoor unit performance data manuals on [www.lghvac.com](http://www.lghvac.com).  
 Low ambient performance with LGRED® heat technology is included in Multi V 5 air source units produced after February 2019.

# FOUR-WAY CEILING CASSETTE



## Cooling Capacity Tables

### ARNU283TMA4, ARNU363TMA4

Table 48: ARNU283TMA4, ARNU363TMA4 Cooling Capacity Table.

Model No. / Capacity Index	Out-door Air Temp. (°F DB)	Indoor Air Temperature (°F DB / WB)													
		68 / 57		73 / 61		79 / 64		80 / 67		85 / 70		88 / 73		91 / 76	
		TC	SHC	TC	SHC	TC	SHC	TC	SHC	TC	SHC	TC	SHC	TC	SHC
ARNU283TMA4 / 28.0	-9.9	18.4	16.3	22.4	18.8	25.2	20.0	28.0	21.3	31.4	22.9	33.4	22.6	36.2	22.6
	-5	18.4	16.3	22.4	18.8	25.2	20.0	28.0	21.3	31.4	22.9	33.4	22.6	36.2	22.6
	0	18.4	16.3	22.4	18.8	25.2	20.0	28.0	21.3	31.4	22.9	33.4	22.6	36.2	22.6
	5	18.4	16.3	22.4	18.8	25.2	20.0	28.0	21.3	31.4	22.9	33.4	22.6	36.2	22.6
	10	18.4	16.3	22.4	18.8	25.2	20.0	28.0	21.3	31.4	22.9	33.4	22.6	36.2	22.6
	14	18.4	16.3	22.4	18.8	25.2	20.0	28.0	21.3	31.4	22.9	33.4	22.6	36.2	22.6
	20	18.4	16.3	22.4	18.8	25.2	20.0	28.0	21.3	31.4	22.9	33.4	22.6	36.2	22.6
	23	18.4	16.3	22.4	18.8	25.2	20.0	28.0	21.3	31.4	22.9	33.4	22.6	36.2	22.6
	25	18.4	16.3	22.4	18.8	25.2	20.0	28.0	21.3	31.4	22.9	33.4	22.6	36.2	22.6
	30	18.4	16.3	22.4	18.8	25.2	20.0	28.0	21.3	31.4	22.9	33.4	22.6	36.2	22.6
	35	18.4	16.3	22.4	18.8	25.2	20.0	28.0	21.3	31.4	22.9	33.4	22.6	36.2	22.6
	40	18.4	16.3	22.4	18.8	25.2	20.0	28.0	21.3	31.4	22.9	33.4	22.6	36.2	22.6
	45	18.4	16.3	22.4	18.8	25.2	20.0	28.0	21.3	31.4	22.9	33.4	22.6	36.2	22.6
	50	18.4	16.3	22.4	18.8	25.2	20.0	28.0	21.3	31.4	22.9	33.4	22.6	36.2	22.6
	55	18.4	16.3	22.4	18.8	25.2	20.0	28.0	21.3	31.4	22.9	33.4	22.6	36.2	22.6
	60	18.4	16.3	22.4	18.8	25.2	20.0	28.0	21.3	31.4	22.9	33.4	22.6	35.8	22.5
	65	18.4	16.3	22.4	18.8	25.2	20.0	28.0	21.3	31.4	22.9	33.4	22.6	35.2	22.1
	70	18.4	16.3	22.4	18.8	25.2	20.0	28.0	21.3	31.4	22.9	33.4	22.6	34.8	21.8
	75	18.4	16.3	22.4	18.8	25.2	20.0	28.0	21.3	31.4	22.9	33.4	22.6	33.8	21.3
	80	18.4	16.3	22.4	18.8	25.2	20.0	28.0	21.3	31.4	22.9	32.4	22.5	33.0	21.2
85	18.4	16.3	22.4	18.8	25.2	20.0	28.0	21.3	31.0	22.6	31.4	21.5	32.0	20.4	
90	18.4	16.3	22.4	18.8	25.2	20.0	28.0	21.3	30.6	22.3	30.8	21.2	31.4	20.1	
95	18.4	16.3	22.4	18.8	25.2	20.0	<b>28.0</b>	<b>21.3</b>	30.0	22.1	30.6	21.1	31.0	19.9	
100	18.4	16.3	22.4	18.8	25.2	20.0	28.0	21.3	29.4	21.8	30.0	20.8	30.6	19.8	
105	18.4	16.3	21.2	17.8	24.0	19.2	26.8	20.4	27.9	20.4	28.8	20.1	29.6	19.3	
110	18.0	15.8	20.2	16.9	22.4	17.8	25.2	19.2	26.4	19.2	27.4	19.2	28.6	18.7	
115	17.5	15.3	19.2	16.0	21.1	16.8	23.7	18.2	24.8	18.2	26.0	18.2	27.4	17.9	
118	17.1	14.9	18.2	15.2	20.0	15.8	22.7	17.3	23.7	17.3	24.9	17.3	26.3	17.2	
122	16.6	14.4	17.3	14.4	18.9	14.8	21.5	16.4	22.4	16.4	23.5	16.4	25.3	16.4	
ARNU363TMA4 / 36.2	-9.9	23.8	20.5	29.0	23.6	32.6	25.1	36.2	26.8	40.6	28.7	43.1	28.4	46.8	28.4
	-5	23.8	20.5	29.0	23.6	32.6	25.1	36.2	26.8	40.6	28.7	43.1	28.4	46.8	28.4
	0	23.8	20.5	29.0	23.6	32.6	25.1	36.2	26.8	40.6	28.7	43.1	28.4	46.8	28.4
	5	23.8	20.5	29.0	23.6	32.6	25.1	36.2	26.8	40.6	28.7	43.1	28.4	46.8	28.4
	10	23.8	20.5	29.0	23.6	32.6	25.1	36.2	26.8	40.6	28.7	43.1	28.4	46.8	28.4
	14	23.8	20.5	29.0	23.6	32.6	25.1	36.2	26.8	40.6	28.7	43.1	28.4	46.8	28.4
	20	23.8	20.5	29.0	23.6	32.6	25.1	36.2	26.8	40.6	28.7	43.1	28.4	46.8	28.4
	23	23.8	20.5	29.0	23.6	32.6	25.1	36.2	26.8	40.6	28.7	43.1	28.4	46.8	28.4
	25	23.8	20.5	29.0	23.6	32.6	25.1	36.2	26.8	40.6	28.7	43.1	28.4	46.8	28.4
	30	23.8	20.5	29.0	23.6	32.6	25.1	36.2	26.8	40.6	28.7	43.1	28.4	46.8	28.4
	35	23.8	20.5	29.0	23.6	32.6	25.1	36.2	26.8	40.6	28.7	43.1	28.4	46.8	28.4
	40	23.8	20.5	29.0	23.6	32.6	25.1	36.2	26.8	40.6	28.7	43.1	28.4	46.8	28.4
	45	23.8	20.5	29.0	23.6	32.6	25.1	36.2	26.8	40.6	28.7	43.1	28.4	46.8	28.4
	50	23.8	20.5	29.0	23.6	32.6	25.1	36.2	26.8	40.6	28.7	43.1	28.4	46.8	28.4
	55	23.8	20.5	29.0	23.6	32.6	25.1	36.2	26.8	40.6	28.7	43.1	28.4	46.8	28.4
	60	23.8	20.5	29.0	23.6	32.6	25.1	36.2	26.8	40.6	28.7	43.1	28.4	46.3	28.3
	65	23.8	20.5	29.0	23.6	32.6	25.1	36.2	26.8	40.6	28.7	43.1	28.4	45.6	27.8
	70	23.8	20.5	29.0	23.6	32.6	25.1	36.2	26.8	40.6	28.7	43.1	28.4	44.9	27.4
	75	23.8	20.5	29.0	23.6	32.6	25.1	36.2	26.8	40.6	28.7	43.1	28.4	43.7	26.8
	80	23.8	20.5	29.0	23.6	32.6	25.1	36.2	26.8	40.6	28.7	41.9	28.3	42.7	26.6
85	23.8	20.5	29.0	23.6	32.6	25.1	36.2	26.8	40.1	28.4	40.6	27.1	41.3	25.6	
90	23.8	20.5	29.0	23.6	32.6	25.1	36.2	26.8	39.5	28.0	39.8	26.6	40.6	25.3	
95	23.8	20.5	29.0	23.6	32.6	25.1	<b>36.2</b>	<b>26.8</b>	38.8	27.8	39.5	26.5	40.1	25.0	
100	23.8	20.5	29.0	23.6	32.6	25.1	36.2	26.8	38.0	27.4	38.8	26.2	39.5	24.8	
105	23.8	20.5	27.5	22.4	31.1	24.1	34.7	25.6	36.1	25.6	37.3	25.3	38.3	24.2	
110	23.2	19.9	26.1	21.2	29.0	22.4	32.6	24.1	34.1	24.1	35.4	24.1	37.0	23.5	
115	22.7	19.3	24.8	20.1	27.2	21.1	30.6	22.9	32.0	22.9	33.7	22.9	35.5	22.5	
118	22.1	18.7	23.5	19.1	25.8	19.8	29.4	21.7	30.6	21.7	32.1	21.7	34.1	21.6	
122	21.5	18.1	22.4	18.2	24.4	18.6	27.8	20.6	29.0	20.6	30.4	20.6	32.7	20.6	

TC: Total Capacity (MBh); SHC: Sensible Heat Capacity (MBh).  
The System Combination Ratio must be between 50~130%.  
Rated capacity is certified under AHRI Standard 1230. Ratings are subject to change without notice.  
Current certified ratings are available at [www.ahridirectory.org](http://www.ahridirectory.org).

For outdoor unit performance data, see the respective outdoor unit performance data manuals on [www.lg-hvac.com](http://www.lg-hvac.com).  
Low ambient performance with LGRED<sup>®</sup> heat technology is included in Multi V 5 air source units produced after February 2019.

Table 49: ARNU423TMC4, ARNU483TMC4 Cooling Capacity Table.

Model No. / Capacity Index	Outdoor Air Temp. (°F DB)	Indoor Air Temperature (°F DB / WB)													
		68 / 57		73 / 61		79 / 64		80 / 67		85 / 70		88 / 73		91 / 76	
		TC	SHC	TC	SHC	TC	SHC	TC	SHC	TC	SHC	TC	SHC	TC	SHC
ARNU423TMC4 / 42.0	-9.9	27.7	23.1	33.6	26.6	37.8	28.3	42.0	30.2	47.1	32.4	50.1	32.1	54.3	32.1
	-5	27.7	23.1	33.6	26.6	37.8	28.3	42.0	30.2	47.1	32.4	50.1	32.1	54.3	32.1
	0	27.7	23.1	33.6	26.6	37.8	28.3	42.0	30.2	47.1	32.4	50.1	32.1	54.3	32.1
	5	27.7	23.1	33.6	26.6	37.8	28.3	42.0	30.2	47.1	32.4	50.1	32.1	54.3	32.1
	10	27.7	23.1	33.6	26.6	37.8	28.3	42.0	30.2	47.1	32.4	50.1	32.1	54.3	32.1
	14	27.7	23.1	33.6	26.6	37.8	28.3	42.0	30.2	47.1	32.4	50.1	32.1	54.3	32.1
	20	27.7	23.1	33.6	26.6	37.8	28.3	42.0	30.2	47.1	32.4	50.1	32.1	54.3	32.1
	23	27.7	23.1	33.6	26.6	37.8	28.3	42.0	30.2	47.1	32.4	50.1	32.1	54.3	32.1
	25	27.7	23.1	33.6	26.6	37.8	28.3	42.0	30.2	47.1	32.4	50.1	32.1	54.3	32.1
	30	27.7	23.1	33.6	26.6	37.8	28.3	42.0	30.2	47.1	32.4	50.1	32.1	54.3	32.1
	35	27.7	23.1	33.6	26.6	37.8	28.3	42.0	30.2	47.1	32.4	50.1	32.1	54.3	32.1
	40	27.7	23.1	33.6	26.6	37.8	28.3	42.0	30.2	47.1	32.4	50.1	32.1	54.3	32.1
	45	27.7	23.1	33.6	26.6	37.8	28.3	42.0	30.2	47.1	32.4	50.1	32.1	54.3	32.1
	50	27.7	23.1	33.6	26.6	37.8	28.3	42.0	30.2	47.1	32.4	50.1	32.1	54.3	32.1
	55	27.7	23.1	33.6	26.6	37.8	28.3	42.0	30.2	47.1	32.4	50.1	32.1	54.3	32.1
	60	27.7	23.1	33.6	26.6	37.8	28.3	42.0	30.2	47.1	32.4	50.1	32.1	53.7	31.9
	65	27.7	23.1	33.6	26.6	37.8	28.3	42.0	30.2	47.1	32.4	50.1	32.1	52.9	31.4
	70	27.7	23.1	33.6	26.6	37.8	28.3	42.0	30.2	47.1	32.4	50.1	32.1	52.2	30.9
	75	27.7	23.1	33.6	26.6	37.8	28.3	42.0	30.2	47.1	32.4	50.1	32.1	50.8	30.2
	80	27.7	23.1	33.6	26.6	37.8	28.3	42.0	30.2	47.1	32.4	48.7	31.9	49.5	30.0
	85	27.7	23.1	33.6	26.6	37.8	28.3	42.0	30.2	46.6	32.1	47.1	30.5	48.0	28.8
	90	27.7	23.1	33.6	26.6	37.8	28.3	42.0	30.2	45.9	31.6	46.2	30.0	47.1	28.5
	95	27.7	23.1	33.6	26.6	37.8	28.3	<b>42.0</b>	<b>30.2</b>	45.0	31.4	45.9	29.9	46.6	28.2
100	27.7	23.1	33.6	26.6	37.8	28.3	42.0	30.2	44.1	30.9	45.0	29.5	45.9	28.0	
105	27.7	23.1	31.9	25.3	36.1	27.1	40.3	28.8	41.9	28.8	43.2	28.5	44.5	27.3	
110	27.0	22.4	30.3	23.9	33.6	25.3	37.8	27.1	39.6	27.1	41.1	27.1	42.9	26.5	
115	26.3	21.7	28.8	22.7	31.6	23.8	35.5	25.8	37.2	25.8	39.1	25.8	41.2	25.4	
118	25.6	21.1	27.3	21.6	30.0	22.3	34.1	24.5	35.5	24.5	37.3	24.5	39.5	24.4	
122	24.9	20.4	26.0	20.5	28.4	21.0	32.3	23.3	33.6	23.3	35.3	23.3	37.9	23.3	
ARNU483TMC4 / 48.1	-9.9	31.7	26.4	38.5	30.5	43.3	32.4	48.1	34.6	53.9	37.1	57.3	36.7	62.1	36.7
	-5	31.7	26.4	38.5	30.5	43.3	32.4	48.1	34.6	53.9	37.1	57.3	36.7	62.1	36.7
	0	31.7	26.4	38.5	30.5	43.3	32.4	48.1	34.6	53.9	37.1	57.3	36.7	62.1	36.7
	5	31.7	26.4	38.5	30.5	43.3	32.4	48.1	34.6	53.9	37.1	57.3	36.7	62.1	36.7
	10	31.7	26.4	38.5	30.5	43.3	32.4	48.1	34.6	53.9	37.1	57.3	36.7	62.1	36.7
	14	31.7	26.4	38.5	30.5	43.3	32.4	48.1	34.6	53.9	37.1	57.3	36.7	62.1	36.7
	20	31.7	26.4	38.5	30.5	43.3	32.4	48.1	34.6	53.9	37.1	57.3	36.7	62.1	36.7
	23	31.7	26.4	38.5	30.5	43.3	32.4	48.1	34.6	53.9	37.1	57.3	36.7	62.1	36.7
	25	31.7	26.4	38.5	30.5	43.3	32.4	48.1	34.6	53.9	37.1	57.3	36.7	62.1	36.7
	30	31.7	26.4	38.5	30.5	43.3	32.4	48.1	34.6	53.9	37.1	57.3	36.7	62.1	36.7
	35	31.7	26.4	38.5	30.5	43.3	32.4	48.1	34.6	53.9	37.1	57.3	36.7	62.1	36.7
	40	31.7	26.4	38.5	30.5	43.3	32.4	48.1	34.6	53.9	37.1	57.3	36.7	62.1	36.7
	45	31.7	26.4	38.5	30.5	43.3	32.4	48.1	34.6	53.9	37.1	57.3	36.7	62.1	36.7
	50	31.7	26.4	38.5	30.5	43.3	32.4	48.1	34.6	53.9	37.1	57.3	36.7	62.1	36.7
	55	31.7	26.4	38.5	30.5	43.3	32.4	48.1	34.6	53.9	37.1	57.3	36.7	62.1	36.7
	60	31.7	26.4	38.5	30.5	43.3	32.4	48.1	34.6	53.9	37.1	57.3	36.7	61.5	36.5
	65	31.7	26.4	38.5	30.5	43.3	32.4	48.1	34.6	53.9	37.1	57.3	36.7	60.5	35.9
	70	31.7	26.4	38.5	30.5	43.3	32.4	48.1	34.6	53.9	37.1	57.3	36.7	59.7	35.4
	75	31.7	26.4	38.5	30.5	43.3	32.4	48.1	34.6	53.9	37.1	57.3	36.7	58.1	34.6
	80	31.7	26.4	38.5	30.5	43.3	32.4	48.1	34.6	53.9	37.1	55.7	36.5	56.7	34.4
	85	31.7	26.4	38.5	30.5	43.3	32.4	48.1	34.6	53.3	36.7	53.9	35.0	54.9	33.0
	90	31.7	26.4	38.5	30.5	43.3	32.4	48.1	34.6	52.5	36.1	52.9	34.4	53.9	32.6
	95	31.7	26.4	38.5	30.5	43.3	32.4	<b>48.1</b>	<b>34.6</b>	51.5	35.9	52.5	34.2	53.3	32.3
100	31.7	26.4	38.5	30.5	43.3	32.4	48.1	34.6	50.5	35.4	51.5	33.8	52.5	32.1	
105	31.7	26.4	36.5	28.9	41.3	31.1	46.1	33.0	48.0	33.0	49.5	32.6	50.9	31.3	
110	30.9	25.6	34.7	27.4	38.5	28.9	43.3	31.1	45.3	31.1	47.1	31.1	49.1	30.3	
115	30.1	24.9	32.9	26.0	36.2	27.2	40.7	29.5	42.6	29.5	44.7	29.5	47.1	29.1	
118	29.3	24.1	31.3	24.7	34.3	25.6	39.1	28.0	40.6	28.0	42.7	28.0	45.3	27.9	
122	28.6	23.4	29.7	23.4	32.5	24.1	36.9	26.6	38.5	26.6	40.4	26.6	43.4	26.6	

Four-Way Ceiling Cassette Product Data

TC: Total Capacity (MBh); SHC: Sensible Heat Capacity (MBh).

The System Combination Ratio must be between 50-130%.

Rated capacity is certified under AHRI Standard 1230. Ratings are subject to change without notice.

Current certified ratings are available at [www.ahrirectory.org](http://www.ahrirectory.org).

For outdoor unit performance data, see the respective outdoor unit performance data manuals on [www.lghvac.com](http://www.lghvac.com).

Low ambient performance with LGRED® heat technology is included in Multi V 5 air source units produced after February 2019.



Due to our policy of continuous product innovation, some specifications may change without notification.

© LG Electronics U.S.A., Inc., Englewood Cliffs, NJ. All rights reserved. "LG" is a registered trademark of LG Corp.

# FOUR-WAY CEILING CASSETTE



## Heating Capacity Tables

### ARNU053TRD4, ARNU073TRD4, ARNU093TRD4, ARNU123TRF4

Table 50: ARNU053TRD4, ARNU073TRD4, ARNU093TRD4, ARNU123TRD4 Heating Capacity Table.

Model No. / Capacity Index	Outdoor Air Temp.		Indoor Air Temperature (°F DB)								
			59	61	64	67	70	73	76	80	
	°F DB	°F WB	TC MBh	TC MBh	TC MBh	TC MBh	TC MBh	TC MBh	TC MBh	TC MBh	
ARNU053TRD4 / 5.5	-21.6	-22.0	3.1	3.1	3.1	3.1	3.1	3.1	3.1	3.1	3.1
	-17.1	-17.5	3.5	3.5	3.5	3.5	3.4	3.4	3.4	3.4	3.4
	-12.6	-13	3.8	3.8	3.8	3.8	3.8	3.8	3.8	3.8	3.8
	-7	-7.6	4.0	4.0	4.0	4.0	3.9	3.9	3.9	3.9	3.9
	-4	-4.4	4.1	4.1	4.1	4.1	4.0	4.0	4.0	4.0	4.0
	0	-0.4	4.2	4.2	4.2	4.2	4.2	4.2	4.2	4.2	4.2
	5	4.5	4.8	4.7	4.6	4.6	4.6	4.6	4.6	4.6	4.6
	10	9	4.9	4.9	4.9	4.9	4.9	4.9	4.9	4.9	4.9
	15	14	5.3	5.3	5.3	5.3	5.3	5.3	5.3	5.2	5.1
	20	19	5.6	5.6	5.6	5.6	5.4	5.4	5.4	5.3	5.3
	25	23	5.8	5.8	5.8	5.8	5.8	5.7	5.6	5.6	5.3
	30	28	5.9	5.9	5.9	5.9	5.9	5.8	5.6	5.6	5.3
	35	32	6.1	6.1	6.1	6.1	6.0	5.9	5.6	5.6	5.3
	40	36	6.3	6.3	6.3	6.3	6.1	5.9	5.6	5.6	5.3
	45	41	6.6	6.6	6.6	6.4	6.1	5.9	5.6	5.6	5.3
	47	43	6.8	6.8	6.7	6.4	<b>6.1</b>	5.9	5.6	5.6	5.3
50	46	7.3	7.0	6.7	6.4	6.1	5.9	5.6	5.6	5.3	
55	51	7.5	7.1	6.7	6.4	6.1	5.9	5.6	5.6	5.3	
60	56	7.5	7.1	6.7	6.4	6.1	5.9	5.6	5.6	5.3	
ARNU073TRD4 / 7.5	-21.6	-22.0	4.3	4.3	4.3	4.3	4.3	4.3	4.3	4.3	4.3
	-17.1	-17.5	4.8	4.8	4.8	4.8	4.8	4.8	4.8	4.8	4.8
	-12.6	-13	5.4	5.4	5.4	5.4	5.3	5.3	5.3	5.3	5.3
	-7	-7.6	5.5	5.5	5.5	5.5	5.4	5.4	5.4	5.4	5.4
	-4	-4.4	5.7	5.7	5.7	5.7	5.6	5.6	5.6	5.6	5.6
	0	-0.4	5.9	5.9	5.9	5.9	5.9	5.8	5.8	5.8	5.8
	5	4.5	6.6	6.6	6.5	6.5	6.5	6.5	6.5	6.5	6.5
	10	9	6.9	6.9	6.9	6.8	6.8	6.8	6.8	6.8	6.8
	15	14	7.3	7.3	7.3	7.3	7.3	7.3	7.2	7.2	7.1
	20	19	7.7	7.7	7.7	7.7	7.6	7.6	7.4	7.4	7.4
	25	23	8.1	8.1	8.1	8.1	8.1	7.9	7.8	7.8	7.4
	30	28	8.3	8.3	8.3	8.3	8.3	8.1	7.8	7.8	7.4
	35	32	8.5	8.5	8.5	8.5	8.4	8.3	7.8	7.8	7.4
	40	36	8.8	8.8	8.8	8.8	8.5	8.3	7.8	7.8	7.4
	45	41	9.2	9.2	9.2	8.9	8.5	8.3	7.8	7.8	7.4
	47	43	9.5	9.4	9.4	8.9	<b>8.5</b>	8.3	7.8	7.8	7.4
50	46	10.2	9.8	9.4	8.9	8.5	8.3	7.8	7.8	7.4	
55	51	10.4	9.9	9.4	8.9	8.5	8.3	7.8	7.8	7.4	
60	56	10.4	9.9	9.4	8.9	8.5	8.3	7.8	7.8	7.4	
ARNU093TRD4 / 9.6	-21.6	-22.0	5.5	5.5	5.5	5.5	5.5	5.5	5.5	5.5	5.5
	-17.1	-17.5	6.2	6.2	6.2	6.2	6.1	6.1	6.1	6.1	6.1
	-12.6	-13	6.9	6.9	6.9	6.9	6.8	6.8	6.8	6.8	6.8
	-7	-7.6	7.1	7.1	7.1	7.1	7.0	7.0	7.0	7.0	7.0
	-4	-4.4	7.3	7.3	7.3	7.3	7.2	7.2	7.2	7.2	7.2
	0	-0.4	7.5	7.5	7.5	7.5	7.5	7.4	7.4	7.4	7.4
	5	4.5	8.5	8.4	8.3	8.3	8.3	8.3	8.3	8.3	8.3
	10	9	8.8	8.8	8.8	8.7	8.7	8.7	8.7	8.7	8.7
	15	14	9.4	9.4	9.4	9.4	9.4	9.4	9.3	9.3	9.2
	20	19	9.9	9.9	9.9	9.9	9.7	9.7	9.5	9.5	9.4
	25	23	10.4	10.4	10.4	10.4	10.4	10.1	10.0	10.0	9.5
	30	28	10.6	10.6	10.6	10.6	10.6	10.4	10.0	10.0	9.5
	35	32	10.9	10.9	10.9	10.9	10.8	10.6	10.0	10.0	9.5
	40	36	11.3	11.3	11.3	11.3	10.9	10.6	10.0	10.0	9.5
	45	41	11.8	11.8	11.8	11.5	10.9	10.6	10.0	10.0	9.5
	47	43	12.2	12.1	12.0	11.5	<b>10.9</b>	10.6	10.0	10.0	9.5
50	46	13.1	12.5	12.0	11.5	10.9	10.6	10.0	10.0	9.5	
55	51	13.4	12.6	12.0	11.5	10.9	10.6	10.0	10.0	9.5	
60	56	13.4	12.6	12.0	11.5	10.9	10.6	10.0	10.0	9.5	

TC: Total Capacity (MBh).

The System Combination Ratio must be between 50–130%.

Rated capacity is certified under AHRI Standard 1230. Ratings are subject to change without notice.

Current certified ratings are available at [www.ahridirectory.org](http://www.ahridirectory.org).

For outdoor unit performance data, see the respective outdoor unit performance data manuals on [www.lghvac.com](http://www.lghvac.com).

Low ambient performance with LGRED® heat technology is included in Multi V 5 air source units produced after February 2019.



Table 51: ARNU153TQD4, ARNU183TQD4 Heating Capacity Table.

Model No. / Capacity Index	Outdoor Air Temp.		Indoor Air Temperature (°F DB)							
	°F DB	°F WB	59	61	64	67	70	73	76	80
			TC MBh	TC MBh	TC MBh	TC MBh	TC MBh	TC MBh	TC MBh	TC MBh
ARNU123TRD4 / 12.3	-21.6	-22.0	6.9	6.9	6.9	6.9	6.8	6.8	6.8	6.8
	-17.1	-17.5	7.7	7.7	7.7	7.7	7.6	7.6	7.6	7.6
	-12.6	-13	8.6	8.6	8.6	8.6	8.5	8.5	8.5	8.5
	-7	-7.6	8.8	8.8	8.8	8.8	8.7	8.7	8.7	8.7
	-4	-4.4	9.1	9.1	9.1	9.1	9.0	9.0	9.0	9.0
	0	-0.4	9.4	9.4	9.4	9.4	9.4	9.3	9.3	9.3
	5	4.5	10.6	10.5	10.3	10.3	10.3	10.3	10.3	10.3
	10	9	11.0	11.0	11.0	10.9	10.9	10.9	10.9	10.9
	15	14	11.7	11.7	11.7	11.7	11.7	11.7	11.6	11.4
	20	19	12.4	12.4	12.4	12.4	12.1	12.1	11.9	11.8
	25	23	12.9	12.9	12.9	12.9	12.9	12.7	12.5	11.9
	30	28	13.2	13.2	13.2	13.2	13.2	12.9	12.5	11.9
	35	32	13.6	13.6	13.6	13.6	13.5	13.2	12.5	11.9
	40	36	14.1	14.1	14.1	14.1	13.6	13.2	12.5	11.9
	45	41	14.7	14.7	14.7	14.3	13.6	13.2	12.5	11.9
47	43	15.2	15.1	15.0	14.3	13.6	13.2	12.5	11.9	
50	46	16.3	15.6	15.0	14.3	13.6	13.2	12.5	11.9	
55	51	16.7	15.8	15.0	14.3	13.6	13.2	12.5	11.9	
60	56	16.7	15.8	15.0	14.3	13.6	13.2	12.5	11.9	
ARNU153TQD4 / 15.4	-21.6	-22.0	8.7	8.7	8.7	8.7	8.6	8.6	8.6	8.6
	-17.1	-17.5	9.7	9.7	9.7	9.7	9.6	9.6	9.6	9.6
	-12.6	-13	10.8	10.8	10.8	10.8	10.6	10.6	10.6	10.6
	-7	-7.6	11.1	11.1	11.1	11.1	10.9	10.9	10.9	10.9
	-4	-4.4	11.5	11.5	11.5	11.5	11.3	11.3	11.3	11.3
	0	-0.4	11.8	11.8	11.8	11.8	11.8	11.6	11.6	11.6
	5	4.5	13.3	13.2	13.0	13.0	13.0	13.0	13.0	13.0
	10	9	13.9	13.9	13.9	13.7	13.7	13.7	13.7	13.7
	15	14	14.7	14.7	14.7	14.7	14.7	14.7	14.5	14.4
	20	19	15.6	15.6	15.6	15.6	15.2	15.2	15.0	14.8
	25	23	16.3	16.3	16.3	16.3	16.3	15.9	15.7	15.0
	30	28	16.6	16.6	16.6	16.6	16.6	16.3	15.7	15.0
	35	32	17.1	17.1	17.1	17.1	16.9	16.6	15.7	15.0
	40	36	17.8	17.8	17.8	17.8	17.1	16.6	15.7	15.0
	45	41	18.5	18.5	18.5	18.0	17.1	16.6	15.7	15.0
47	43	19.2	19.0	18.8	18.0	<b>17.1</b>	16.6	15.7	15.0	
50	46	20.5	19.7	18.8	18.0	17.1	16.6	15.7	15.0	
55	51	21.0	19.8	18.8	18.0	17.1	16.6	15.7	15.0	
60	56	21.0	19.8	18.8	18.0	17.1	16.6	15.7	15.0	
ARNU183TQD4 / 19.1	-21.6	-22.0	10.9	10.9	10.9	10.9	10.8	10.8	10.8	10.8
	-17.1	-17.5	12.2	12.2	12.2	12.2	12.1	12.1	12.1	12.1
	-12.6	-13	13.6	13.6	13.6	13.6	13.4	13.4	13.4	13.4
	-7	-7.6	14.0	14.0	14.0	14.0	13.8	13.8	13.8	13.8
	-4	-4.4	14.4	14.4	14.4	14.4	14.2	14.2	14.2	14.2
	0	-0.4	14.8	14.8	14.8	14.8	14.8	14.6	14.6	14.6
	5	4.5	16.8	16.6	16.3	16.3	16.3	16.3	16.3	16.3
	10	9	17.4	17.4	17.4	17.2	17.2	17.2	17.2	17.2
	15	14	18.5	18.5	18.5	18.5	18.5	18.5	18.3	18.1
	20	19	19.6	19.6	19.6	19.6	19.1	19.1	18.8	18.6
	25	23	20.4	20.4	20.4	20.4	20.4	20.0	19.8	18.8
	30	28	20.9	20.9	20.9	20.9	20.9	20.4	19.8	18.8
	35	32	21.5	21.5	21.5	21.5	21.3	20.9	19.8	18.8
	40	36	22.4	22.4	22.4	22.4	21.5	20.9	19.8	18.8
	45	41	23.2	23.2	23.2	22.6	21.5	20.9	19.8	18.8
47	43	24.1	23.9	23.7	22.6	<b>21.5</b>	20.9	19.8	18.8	
50	46	25.8	24.7	23.7	22.6	21.5	20.9	19.8	18.8	
55	51	26.3	24.9	23.7	22.6	21.5	20.9	19.8	18.8	
60	56	26.3	24.9	23.7	22.6	21.5	20.9	19.8	18.8	

Four-Way Ceiling Cassette Product Data

TC: Total Capacity (MBh).

The System Combination Ratio must be between 50–130%.

Rated capacity is certified under AHRI Standard 1230. Ratings are subject to change without notice. Current certified ratings are available at [www.ahridirectory.org](http://www.ahridirectory.org).

For outdoor unit performance data, see the respective outdoor unit performance data manuals on [www.lghvac.com](http://www.lghvac.com).

Low ambient performance with LGRED® heat technology is included in Multi V 5 air source units produced after February 2019.



# FOUR-WAY CEILING CASSETTE



## Heating Capacity Tables

### ARNU073TNA4, ARNU093TNA4

Table 52: ARNU073TNA4, ARNU093TNA4, ARNU123TNA4, ARNU153TNA4 Heating Capacity Table.

Model No. / Capacity Index	Outdoor Air Temp.		Indoor Air Temperature (°F DB)							
			59	61	64	67	70	73	76	80
	°F DB	°F WB	TC MBh	TC MBh	TC MBh	TC MBh	TC MBh	TC MBh	TC MBh	TC MBh
ARNU073TNA4 / 7.5	-21.6	-22.0	4.3	4.3	4.3	4.3	4.3	4.3	4.3	4.3
	-17.1	-17.5	4.8	4.8	4.8	4.8	4.8	4.8	4.8	4.8
	-12.6	-13	5.4	5.4	5.4	5.4	5.3	5.3	5.3	5.3
	-7	-7.6	5.5	5.5	5.5	5.5	5.4	5.4	5.4	5.4
	-4	-4.4	5.7	5.7	5.7	5.7	5.6	5.6	5.6	5.6
	0	-0.4	5.9	5.9	5.9	5.9	5.9	5.8	5.8	5.8
	5	4.5	6.6	6.6	6.5	6.5	6.5	6.5	6.5	6.5
	10	9	6.9	6.9	6.9	6.8	6.8	6.8	6.8	6.8
	15	14	7.3	7.3	7.3	7.3	7.3	7.3	7.2	7.1
	20	19	7.7	7.7	7.7	7.7	7.6	7.6	7.4	7.4
	25	23	8.1	8.1	8.1	8.1	8.1	7.9	7.8	7.4
	30	28	8.3	8.3	8.3	8.3	8.3	8.1	7.8	7.4
	35	32	8.5	8.5	8.5	8.5	8.4	8.3	7.8	7.4
	40	36	8.8	8.8	8.8	8.8	8.5	8.3	7.8	7.4
	45	41	9.2	9.2	9.2	8.9	8.5	8.3	7.8	7.4
47	43	9.5	9.4	9.4	8.9	<b>8.5</b>	8.3	7.8	7.4	
50	46	10.2	9.8	9.4	8.9	8.5	8.3	7.8	7.4	
55	51	10.4	9.9	9.4	8.9	8.5	8.3	7.8	7.4	
60	56	10.4	9.9	9.4	8.9	8.5	8.3	7.8	7.4	
ARNU093TNA4 / 9.6	-21.6	-22.0	5.5	5.5	5.5	5.5	5.5	5.5	5.5	5.5
	-17.1	-17.5	6.2	6.2	6.2	6.2	6.1	6.1	6.1	6.1
	-12.6	-13	6.9	6.9	6.9	6.9	6.8	6.8	6.8	6.8
	-7	-7.6	7.1	7.1	7.1	7.1	7.0	7.0	7.0	7.0
	-4	-4.4	7.3	7.3	7.3	7.3	7.2	7.2	7.2	7.2
	0	-0.4	7.5	7.5	7.5	7.5	7.5	7.4	7.4	7.4
	5	4.5	8.5	8.4	8.3	8.3	8.3	8.3	8.3	8.3
	10	9	8.8	8.8	8.8	8.7	8.7	8.7	8.7	8.7
	15	14	9.4	9.4	9.4	9.4	9.4	9.4	9.3	9.2
	20	19	9.9	9.9	9.9	9.9	9.7	9.7	9.5	9.4
	25	23	10.4	10.4	10.4	10.4	10.4	10.1	10.0	9.5
	30	28	10.6	10.6	10.6	10.6	10.6	10.4	10.0	9.5
	35	32	10.9	10.9	10.9	10.9	10.8	10.6	10.0	9.5
	40	36	11.3	11.3	11.3	11.3	10.9	10.6	10.0	9.5
	45	41	11.8	11.8	11.8	11.5	10.9	10.6	10.0	9.5
47	43	12.2	12.1	12.0	11.5	<b>10.9</b>	10.6	10.0	9.5	
50	46	13.1	12.5	12.0	11.5	10.9	10.6	10.0	9.5	
55	51	13.4	12.6	12.0	11.5	10.9	10.6	10.0	9.5	
60	56	13.4	12.6	12.0	11.5	10.9	10.6	10.0	9.5	

TC: Total Capacity (MBh).

The System Combination Ratio must be between 50–130%.

Rated capacity is certified under AHRI Standard 1230. Ratings are subject to change without notice. Current certified ratings are available at [www.ahridirectory.org](http://www.ahridirectory.org).

For outdoor unit performance data, see the respective outdoor unit performance data manuals on [www.lghvac.com](http://www.lghvac.com).

Low ambient performance with LGRED® heat technology is included in Multi V 5 air source units produced after February 2019.





Table 53: ARNU073TNA4, ARNU093TNA4, ARNU123TNA4, ARNU153TNA4 Heating Capacity Table.

Model No. / Capacity Index	Outdoor Air Temp.		Indoor Air Temperature (°F DB)							
			59	61	64	67	70	73	76	80
	°F DB	°F WB	TC	TC	TC	TC	TC	TC	TC	TC
ARNU123TNA4 / 12.3	-21.6	-22.0	6.9	6.9	6.9	6.9	6.8	6.8	6.8	6.8
	-17.1	-17.5	7.7	7.7	7.7	7.7	7.6	7.6	7.6	7.6
	-12.6	-13	8.6	8.6	8.6	8.6	8.5	8.5	8.5	8.5
	-7	-7.6	8.8	8.8	8.8	8.8	8.7	8.7	8.7	8.7
	-4	-4.4	9.1	9.1	9.1	9.1	9.0	9.0	9.0	9.0
	0	-0.4	9.4	9.4	9.4	9.4	9.4	9.3	9.3	9.3
	5	4.5	10.6	10.5	10.3	10.3	10.3	10.3	10.3	10.3
	10	9	11.0	11.0	11.0	10.9	10.9	10.9	10.9	10.9
	15	14	11.7	11.7	11.7	11.7	11.7	11.7	11.6	11.4
	20	19	12.4	12.4	12.4	12.4	12.1	12.1	11.9	11.8
	25	23	12.9	12.9	12.9	12.9	12.9	12.7	12.5	11.9
	30	28	13.2	13.2	13.2	13.2	13.2	12.9	12.5	11.9
	35	32	13.6	13.6	13.6	13.6	13.5	13.2	12.5	11.9
	40	36	14.1	14.1	14.1	14.1	13.6	13.2	12.5	11.9
	45	41	14.7	14.7	14.7	14.3	13.6	13.2	12.5	11.9
47	43	15.2	15.1	15.0	14.3	<b>13.6</b>	13.2	12.5	11.9	
50	46	16.3	15.6	15.0	14.3	13.6	13.2	12.5	11.9	
55	51	16.7	15.8	15.0	14.3	13.6	13.2	12.5	11.9	
60	56	16.7	15.8	15.0	14.3	13.6	13.2	12.5	11.9	
ARNU153TNA4 / 15.4	-21.6	-22.0	8.7	8.7	8.7	8.7	8.6	8.6	8.6	8.6
	-17.1	-17.5	9.7	9.7	9.7	9.7	9.6	9.6	9.6	9.6
	-12.6	-13	10.8	10.8	10.8	10.8	10.6	10.6	10.6	10.6
	-7	-7.6	11.1	11.1	11.1	11.1	10.9	10.9	10.9	10.9
	-4	-4.4	11.5	11.5	11.5	11.5	11.3	11.3	11.3	11.3
	0	-0.4	11.8	11.8	11.8	11.8	11.8	11.6	11.6	11.6
	5	4.5	13.3	13.2	13.0	13.0	13.0	13.0	13.0	13.0
	10	9	13.9	13.9	13.9	13.7	13.7	13.7	13.7	13.7
	15	14	14.7	14.7	14.7	14.7	14.7	14.7	14.5	14.4
	20	19	15.6	15.6	15.6	15.6	15.2	15.2	15.0	14.8
	25	23	16.3	16.3	16.3	16.3	16.3	15.9	15.7	15.0
	30	28	16.6	16.6	16.6	16.6	16.6	16.3	15.7	15.0
	35	32	17.1	17.1	17.1	17.1	16.9	16.6	15.7	15.0
	40	36	17.8	17.8	17.8	17.8	17.1	16.6	15.7	15.0
	45	41	18.5	18.5	18.5	18.0	17.1	16.6	15.7	15.0
47	43	19.2	19.0	18.8	18.0	<b>17.1</b>	16.6	15.7	15.0	
50	46	20.5	19.7	18.8	18.0	17.1	16.6	15.7	15.0	
55	51	21.0	19.8	18.8	18.0	17.1	16.6	15.7	15.0	
60	56	21.0	19.8	18.8	18.0	17.1	16.6	15.7	15.0	

TC: Total Capacity (MBh).

The System Combination Ratio must be between 50–130%.

Rated capacity is certified under AHRI Standard 1230. Ratings are subject to change without notice. Current certified ratings are available at [www.ahridirectory.org](http://www.ahridirectory.org).

For outdoor unit performance data, see the respective outdoor unit performance data manuals on [www.lghvac.com](http://www.lghvac.com).

Low ambient performance with LGRED® heat technology is included in Multi V 5 air source units produced after February 2019.

# FOUR-WAY CEILING CASSETTE



## Heating Capacity Tables

### ARNU183TNA4, ARNU243TNA4

Table 54: ARNU183TNA4, ARNU243TNA4 Heating Capacity Table.

Model No. / Capacity Index	Outdoor Air Temp.		Indoor Air Temperature (°F DB)							
			59	61	64	67	70	73	76	80
	°F DB	°F WB	TC MBh	TC MBh	TC MBh	TC MBh	TC MBh	TC MBh	TC MBh	TC MBh
ARNU183TNA4 / 19.1	-21.6	-22.0	10.9	10.9	10.9	10.9	10.8	10.8	10.8	10.8
	-17.1	-17.5	12.2	12.2	12.2	12.2	12.1	12.1	12.1	12.1
	-12.6	-13	13.6	13.6	13.6	13.6	13.4	13.4	13.4	13.4
	-7	-7.6	14.0	14.0	14.0	14.0	13.8	13.8	13.8	13.8
	-4	-4.4	14.4	14.4	14.4	14.4	14.2	14.2	14.2	14.2
	0	-0.4	14.8	14.8	14.8	14.8	14.8	14.6	14.6	14.6
	5	4.5	16.8	16.6	16.3	16.3	16.3	16.3	16.3	16.3
	10	9	17.4	17.4	17.4	17.2	17.2	17.2	17.2	17.2
	15	14	18.5	18.5	18.5	18.5	18.5	18.5	18.3	18.1
	20	19	19.6	19.6	19.6	19.6	19.1	19.1	18.8	18.6
	25	23	20.4	20.4	20.4	20.4	20.4	20.0	19.8	18.8
	30	28	20.9	20.9	20.9	20.9	20.9	20.4	19.8	18.8
	35	32	21.5	21.5	21.5	21.5	21.3	20.9	19.8	18.8
	40	36	22.4	22.4	22.4	22.4	21.5	20.9	19.8	18.8
	45	41	23.2	23.2	23.2	22.6	21.5	20.9	19.8	18.8
47	43	24.1	23.9	23.7	22.6	<b>21.5</b>	20.9	19.8	18.8	
50	46	25.8	24.7	23.7	22.6	21.5	20.9	19.8	18.8	
55	51	26.3	24.9	23.7	22.6	21.5	20.9	19.8	18.8	
60	56	26.3	24.9	23.7	22.6	21.5	20.9	19.8	18.8	
ARNU243TNA4 / 24.2	-21.6	-22.0	13.9	13.9	13.9	13.9	13.7	13.7	13.7	13.7
	-17.1	-17.5	15.5	15.5	15.5	15.5	15.3	15.3	15.3	15.3
	-12.6	-13	17.2	17.2	17.2	17.2	17.0	17.0	17.0	17.0
	-7	-7.6	17.8	17.8	17.8	17.8	17.5	17.5	17.5	17.5
	-4	-4.4	18.3	18.3	18.3	18.3	18.0	18.0	18.0	18.0
	0	-0.4	18.8	18.8	18.8	18.8	18.8	18.6	18.6	18.6
	5	4.5	21.3	21.0	20.8	20.8	20.8	20.8	20.8	20.8
	10	9	22.1	22.1	22.1	21.8	21.8	21.8	21.8	21.8
	15	14	23.5	23.5	23.5	23.5	23.5	23.5	23.2	22.9
	20	19	24.8	24.8	24.8	24.8	24.3	24.3	23.9	23.6
	25	23	25.9	25.9	25.9	25.9	25.9	25.4	25.1	23.9
	30	28	26.5	26.5	26.5	26.5	26.5	25.9	25.1	23.9
	35	32	27.3	27.3	27.3	27.3	27.0	26.5	25.1	23.9
	40	36	28.4	28.4	28.4	28.4	27.3	26.5	25.1	23.9
	45	41	29.5	29.5	29.5	28.7	27.3	26.5	25.1	23.9
47	43	30.6	30.3	30.0	28.7	<b>27.3</b>	26.5	25.1	23.9	
50	46	32.8	31.4	30.0	28.7	27.3	26.5	25.1	23.9	
55	51	33.4	31.7	30.0	28.7	27.3	26.5	25.1	23.9	
60	56	33.4	31.7	30.0	28.7	27.3	26.5	25.1	23.9	

TC: Total Capacity (MBh).

The System Combination Ratio must be between 50–130%.

Rated capacity is certified under AHRI Standard 1230. Ratings are subject to change without notice. Current certified ratings are available at [www.ahridirectory.org](http://www.ahridirectory.org).

For outdoor unit performance data, see the respective outdoor unit performance data manuals on [www.lghvac.com](http://www.lghvac.com).

Low ambient performance with LGRED® heat technology is included in Multi V 5 air source units produced after February 2019.



Table 55: ARNU283TMA4, ARNU363TMA4, ARNU423TMC4 Heating Capacity Table.

Model No. / Capacity Index	Outdoor Air Temp.		Indoor Air Temperature (°F DB)							
	°F DB	°F WB	59	61	64	67	70	73	76	80
			TC MBh	TC MBh	TC MBh	TC MBh	TC MBh	TC MBh	TC MBh	TC MBh
ARNU283TMA4 / 28.0	-21.6	-22.0	16.0	16.0	16.0	16.0	15.8	15.8	15.8	15.8
	-17.1	-17.5	17.9	17.9	17.9	17.9	17.7	17.7	17.7	17.7
	-12.6	-13	19.9	19.9	19.9	19.9	19.6	19.6	19.6	19.6
	-7	-7.6	20.5	20.5	20.5	20.5	20.2	20.2	20.2	20.2
	-4	-4.4	21.1	21.1	21.1	21.1	20.8	20.8	20.8	20.8
	0	-0.4	21.7	21.7	21.7	21.7	21.7	21.4	21.4	21.4
	5	4.5	24.6	24.3	23.9	23.9	23.9	23.9	23.9	23.9
	10	9	25.5	25.5	25.5	25.2	25.2	25.2	25.2	25.2
	15	14	27.1	27.1	27.1	27.1	27.1	27.1	26.8	26.5
	20	19	28.7	28.7	28.7	28.7	28.0	28.0	27.6	27.3
	25	23	29.9	29.9	29.9	29.9	29.9	29.3	29.0	27.6
	30	28	30.6	30.6	30.6	30.6	30.6	29.9	29.0	27.6
	35	32	31.5	31.5	31.5	31.5	31.2	30.6	29.0	27.6
	40	36	32.8	32.8	32.8	32.8	31.5	30.6	29.0	27.6
	45	41	34.0	34.0	34.0	33.1	31.5	30.6	29.0	27.6
	47	43	35.3	35.0	34.7	33.1	<b>31.5</b>	30.6	29.0	27.6
50	46	37.8	36.2	34.7	33.1	31.5	30.6	29.0	27.6	
55	51	38.6	36.5	34.7	33.1	31.5	30.6	29.0	27.6	
60	56	38.6	36.5	34.7	33.1	31.5	30.6	29.0	27.6	
ARNU363TMA4 / 36.2	-21.6	-22.0	20.6	20.6	20.6	20.6	20.3	20.3	20.3	20.3
	-17.1	-17.5	23.1	23.1	23.1	23.1	22.8	22.8	22.8	22.8
	-12.6	-13	25.6	25.6	25.6	25.6	25.2	25.2	25.2	25.2
	-7	-7.6	26.4	26.4	26.4	26.4	26.0	26.0	26.0	26.0
	-4	-4.4	27.2	27.2	27.2	27.2	26.8	26.8	26.8	26.8
	0	-0.4	28.0	28.0	28.0	28.0	28.0	27.6	27.6	27.6
	5	4.5	31.7	31.3	30.9	30.9	30.9	30.9	30.9	30.9
	10	9	32.9	32.9	32.9	32.5	32.5	32.5	32.5	32.5
	15	14	34.9	34.9	34.9	34.9	34.9	34.9	34.5	34.1
	20	19	37.0	37.0	37.0	37.0	36.1	36.1	35.5	35.1
	25	23	38.6	38.6	38.6	38.6	38.6	37.8	37.4	35.5
	30	28	39.4	39.4	39.4	39.4	39.4	38.6	37.4	35.5
	35	32	40.6	40.6	40.6	40.6	40.2	39.4	37.4	35.5
	40	36	42.2	42.2	42.2	42.2	40.6	39.4	37.4	35.5
	45	41	43.9	43.9	43.9	42.6	40.6	39.4	37.4	35.5
	47	43	45.5	45.1	44.7	42.6	<b>40.6</b>	39.4	37.4	35.5
50	46	48.7	46.7	44.7	42.6	40.6	39.4	37.4	35.5	
55	51	49.7	47.1	44.7	42.6	40.6	39.4	37.4	35.5	
60	56	49.7	47.1	44.7	42.6	40.6	39.4	37.4	35.5	

Four-Way Ceiling Cassette Product Data

TC: Total Capacity (MBh).

The System Combination Ratio must be between 50–130%.

Rated capacity is certified under AHRI Standard 1230. Ratings are subject to change without notice. Current certified ratings are available at [www.ahridirectory.org](http://www.ahridirectory.org).

For outdoor unit performance data, see the respective outdoor unit performance data manuals on [www.lghvac.com](http://www.lghvac.com).

Low ambient performance with LGRED® heat technology is included in Multi V 5 air source units produced after February 2019.

# FOUR-WAY CEILING CASSETTE



## Heating Capacity Tables

### ARNU483TMC4

Table 56: ARNU483TMC4 Heating Capacity Table.

Model No. / Capacity Index	Outdoor Air Temp.		Indoor Air Temperature (°F DB)							
	°F DB	°F WB	59	61	64	67	70	73	76	80
			TC MBh	TC MBh	TC MBh	TC MBh	TC MBh	TC MBh	TC MBh	TC MBh
ARNU423TMC4 / 42.0	-21.6	-22.0	22.2	22.2	22.2	22.2	21.9	21.9	21.9	21.9
	-17.1	-17.5	24.9	24.9	24.9	24.9	24.6	24.6	24.6	24.6
	-12.6	-13	27.6	27.6	27.6	27.6	27.2	27.2	27.2	27.2
	-7	-7.6	28.5	28.5	28.5	28.5	28.0	28.0	28.0	28.0
	-4	-4.4	29.4	29.4	29.4	29.4	28.9	28.9	28.9	28.9
	0	-0.4	30.2	30.2	30.2	30.2	30.2	29.8	29.8	29.8
	5	4.5	34.2	33.7	33.3	33.3	33.3	33.3	33.3	33.3
	10	9	35.5	35.5	35.5	35.0	35.0	35.0	35.0	35.0
	15	14	37.7	37.7	37.7	37.7	37.7	37.7	37.2	36.8
	20	19	39.9	39.9	39.9	39.9	39.0	39.0	38.3	37.9
	25	23	41.6	41.6	41.6	41.6	41.6	40.7	40.3	38.3
	30	28	42.5	42.5	42.5	42.5	42.5	41.6	40.3	38.3
	35	32	43.8	43.8	43.8	43.8	43.4	42.5	40.3	38.3
	40	36	45.6	45.6	45.6	45.6	43.8	42.5	40.3	38.3
	45	41	47.3	47.3	47.3	46.0	43.8	42.5	40.3	38.3
ARNU483TMC4 / 48.1	-21.6	-22.0	26.0	26.0	26.0	26.0	25.6	25.6	25.6	25.6
	-17.1	-17.5	29.1	29.1	29.1	29.1	28.7	28.7	28.7	28.7
	-12.6	-13	32.3	32.3	32.3	32.3	31.8	31.8	31.8	31.8
	-7	-7.6	33.3	33.3	33.3	33.3	32.8	32.8	32.8	32.8
	-4	-4.4	34.3	34.3	34.3	34.3	33.8	33.8	33.8	33.8
	0	-0.4	35.3	35.3	35.3	35.3	35.3	34.8	34.8	34.8
	5	4.5	39.9	39.4	38.9	38.9	38.9	38.9	38.9	38.9
	10	9	41.5	41.5	41.5	41.0	41.0	41.0	41.0	41.0
	15	14	44.0	44.0	44.0	44.0	44.0	44.0	43.5	43.0
	20	19	46.6	46.6	46.6	46.6	45.6	45.6	44.8	44.3
	25	23	48.6	48.6	48.6	48.6	48.6	47.6	47.1	44.8
	30	28	49.7	49.7	49.7	49.7	49.7	48.6	47.1	44.8
	35	32	51.2	51.2	51.2	51.2	50.7	49.7	47.1	44.8
	40	36	53.3	53.3	53.3	53.3	51.2	49.7	47.1	44.8
	45	41	55.3	55.3	55.3	53.8	51.2	49.7	47.1	44.8
47	43	57.3	56.8	56.3	53.8	<b>51.2</b>	49.7	47.1	44.8	
50	46	61.4	58.9	56.3	53.8	51.2	49.7	47.1	44.8	
55	51	62.7	59.4	56.3	53.8	51.2	49.7	47.1	44.8	
60	56	62.7	59.4	56.3	53.8	51.2	49.7	47.1	44.8	

TC: Total Capacity (MBh).

The System Combination Ratio must be between 50–130%.

Rated capacity is certified under AHRI Standard 1230. Ratings are subject to change without notice. Current certified ratings are available at [www.ahridirectory.org](http://www.ahridirectory.org).

For outdoor unit performance data, see the respective outdoor unit performance data manuals on [www.lghvac.com](http://www.lghvac.com).

Low ambient performance with LGRED® heat technology is included in Multi V 5 air source units produced after February 2019.



Table 57: Optional Accessories for Four-Way Ceiling Cassette Indoor Units.

Accessory	Model Number
24-7/16" x 24-7/16" (2' x 2') Four-Way Ceiling Cassette Grille Kit — White (One Required)	PT-QCHW0 (For 5~19MBh TR and TQ Frame Indoor Units)
27-9/16" x 27-9/16" (2' x 2') Four-Way Ceiling Cassette Grille Kit — White (One Required)	PT-UQC (For 5~19MBh TR and TQ Frame Indoor Units)
3' x 3' Four-Way Ceiling Cassette Grille Kit — White (One Required)	PT-UMC1 (For 7~48MBh TN, TM Frame Indoor Units)
Ventilation Kit <sup>1</sup>	PTVK410 + PTVK420
Ventilation Kit <sup>2</sup>	PTVK430
Auto Elevation Kit <sup>1</sup>	PTEGM0
Cassette Decorative Cover <sup>2</sup>	PTDCQ (For 5~19MBh TR and TQ Frame Indoor Units) PTDCM (For 7~48MBh TN, TM Frame Indoor Units)
Auxiliary Heater Kit <sup>2</sup>	PRARH1
Wi-Fi Module <sup>2</sup>	PWFMDD200

<sup>1</sup>For use with TN and TM frame four-way ceiling-cassette indoor units.

<sup>2</sup>For use with all four-way ceiling-cassette indoor units.

All accessories are sold separately.

# APPLICATION GUIDELINES

**Selecting the Best Location on page 127**

**General Mounting on page 128**

**General Drain Piping Information on page 129**

**Wiring Guidelines on page 131**

**Wired Controller Location on page 136**

**Acronyms on page 137**

**Selecting the Best Location**

**Do's**

- Place the unit where air circulation will not be blocked.
- Place the unit where drainage can be obtained easily and to minimize the length of the condensate drain piping.
- Place the unit where noise prevention is taken into consideration.
- Ensure there is sufficient space from the ceiling and floor.
- Ensure there is sufficient maintenance space.
- Locate the indoor unit in a location where it can be easily connected to the outdoor unit / heat recovery unit.

**Do Not's**

- Avoid installing the unit near high-frequency generators.
- Do not install the unit near a doorway.
- The unit must not be installed near a heat or steam source, or where considerable amounts of oil, iron powder, or flour are used. (These materials may generate condensate, cause a reduction in heat exchanger efficiency, or the drain pump to malfunction. If this is a potential problem, install a ventilation fan large enough to vent out these materials.)

**WARNING**

The unit must not be installed where sulfuric acid and flammable or corrosive gases are generated, vented into, or stored. There is risk of fire, explosion, and physical injury or death.

The unit may be damaged, may malfunction, and / or will not operate as designed if installed in any of the conditions listed.

**Note:**

- Indoor units (IDUs) should not be placed in an environment where the IDUs may be exposed to harmful volatile organic compounds (VOCs) or in environments where there is improper air make up or supply or inadequate ventilation. If there are concerns about VOCs in the environment where the IDUs are installed, proper air make up or supply and/or adequate ventilation should be provided. Additionally, in buildings where IDUs will be exposed to VOCs, consider a third party factory-applied epoxy coating to the fan coils for each IDU where the entire coil is dipped, not sprayed.
- If the unit is installed near a body of water, the installation parts are at risk of corroding. Appropriate anti-corrosion methods must be taken for the unit and all installation parts.

**Installing in an Area Exposed to Unconditioned Air**

In some installation applications, areas (floors, walls) in some rooms may be exposed to unconditioned air (room may be above or next to an unheated garage or storeroom). To countermeasure:

- Verify that carpet is or will be installed (carpet may increase the temperature by three [3] degrees).
- Add insulation between the floor joists.
- Install radiant heat or another type of heating system to the floor.

Figure 83: Selecting the Best Location / Minimum Clearance Requirements — One-, Two-, and Four-Way Ceiling-Cassette Indoor Units.

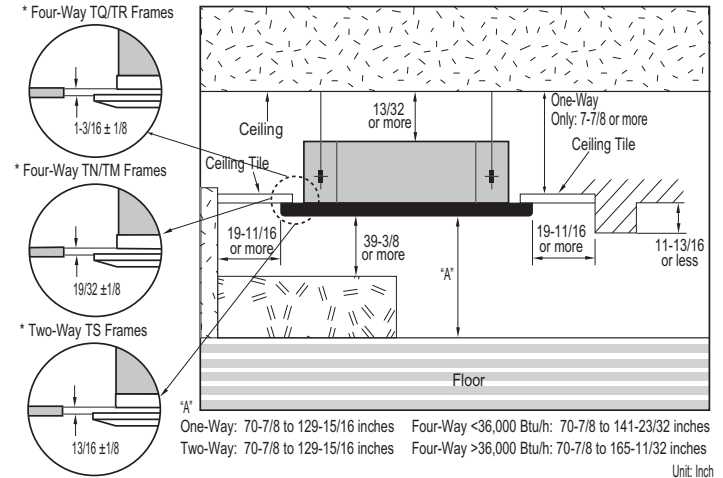
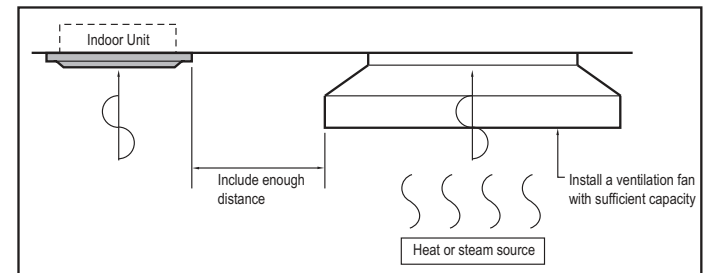

Figure 84: Installing Near a Heat or Steam Source.



### General Mounting

The ceiling must be strong and solid enough to protect the unit from vibration. All ceiling-cassette indoor units include a pattern to help determine the size necessary for the opening in the false ceiling (paper pattern dimensions match those for the ceiling opening dimensions), and where the hanging bolts and refrigerant / drain piping are placed.

Figure 85: Ceiling Opening / Hanging Bolt Locations for One-Way Ceiling Cassette Indoor Units.

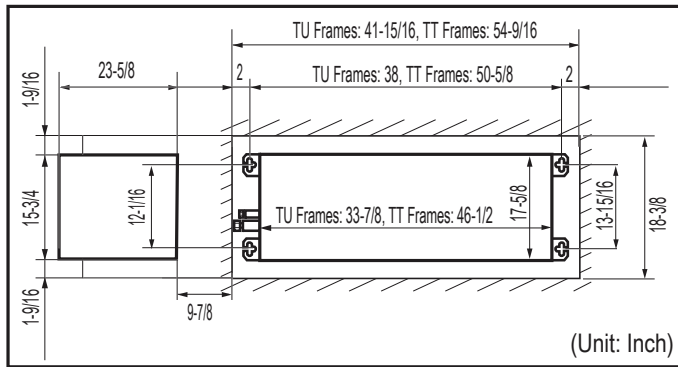

Figure 86: Ceiling Opening / Hanging Bolt Locations for Two-Way Ceiling Cassette Indoor Units.

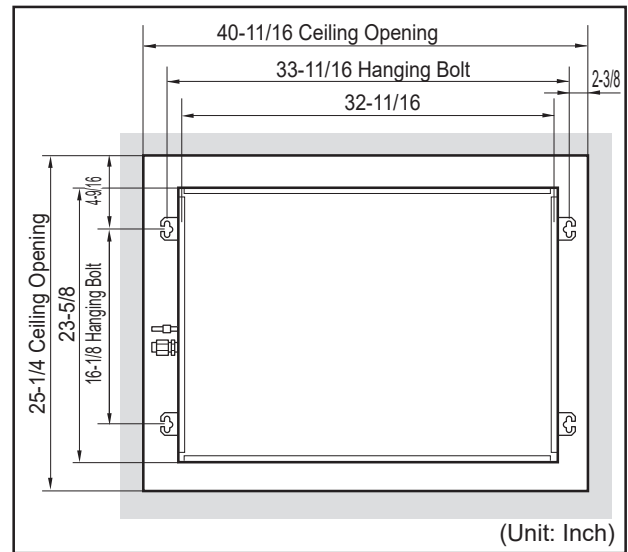
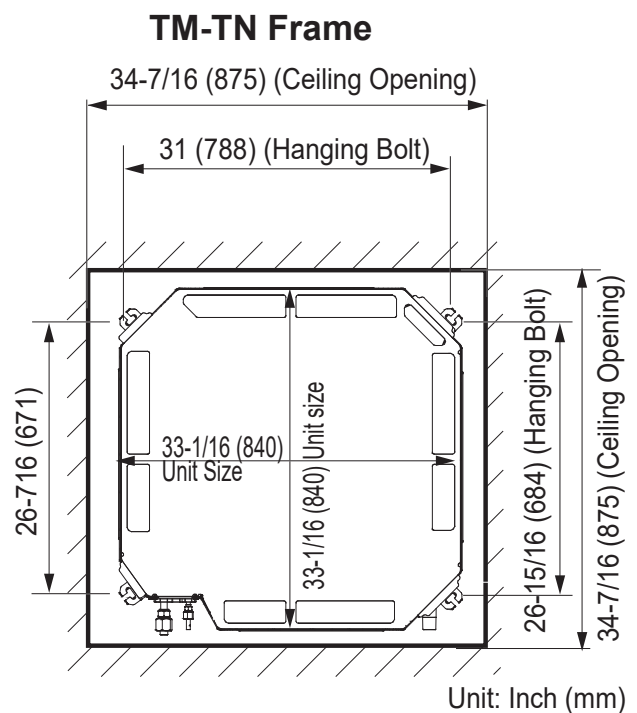
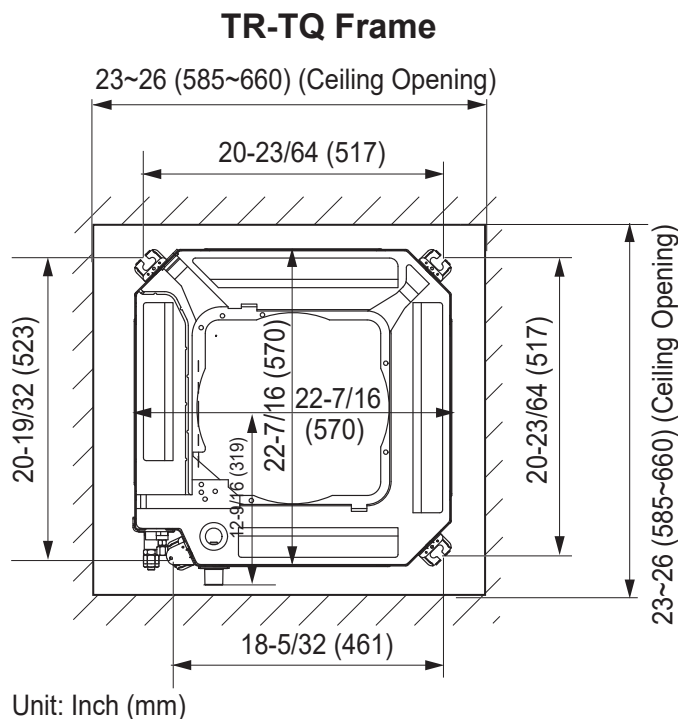

Figure 87: Ceiling Opening / Hanging Bolt Locations for Four-Way Ceiling Cassette Indoor Units.





### General Mounting Procedure

- Using the included paper pattern, select and mark the area where the hanging bolts, refrigerant and condensate piping will be placed. The hanging bolts must be slightly tilted to the direction of the drain hose.
- Drill the holes.
- Install the unit horizontally using a level gauge.

### ⚠ WARNING

⊘ Do not damage power wiring during installation. There is risk of electric shock, which may result in physical injury or death.

### Note:

⊘ Do not damage power wiring during installation. There is a risk of equipment malfunction, which may result in property damage.

Figure 88: Using the Paper Pattern / Drilling Holes for the Bolts, Refrigerant and Condensate Piping.

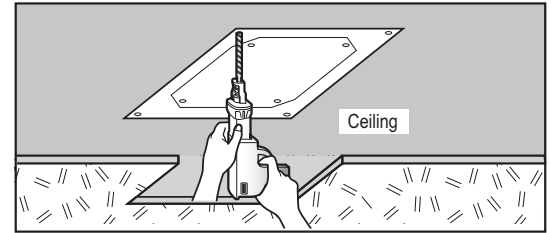
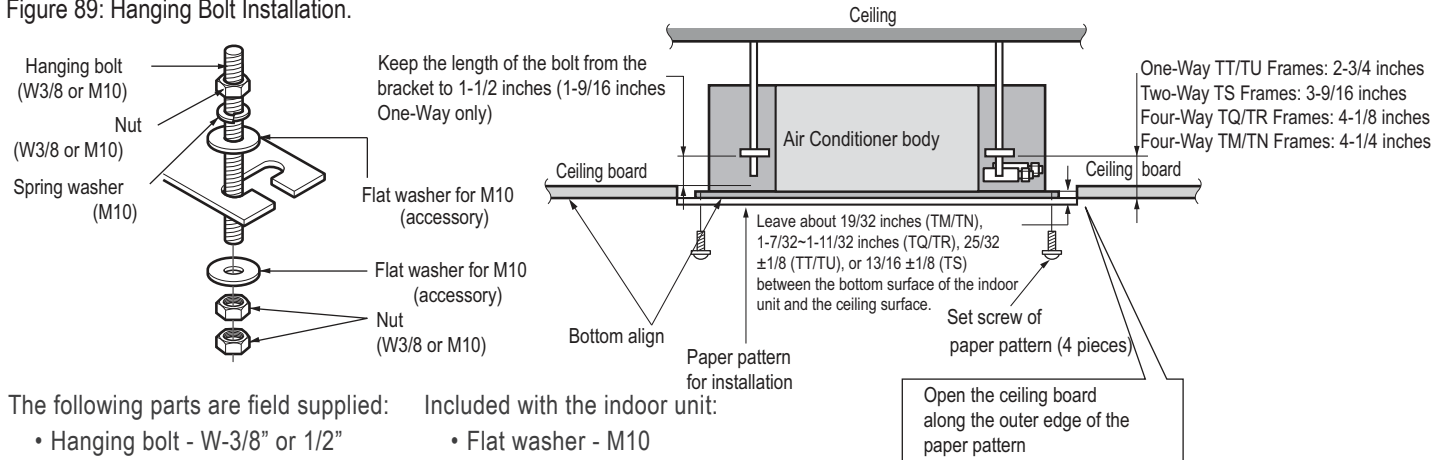

Figure 89: Hanging Bolt Installation.



The following parts are field supplied: Included with the indoor unit:

- Hanging bolt - W-3/8" or 1/2"
- Nut - W-3/8" or M10
- Spring washer - M10
- Flat washer - M10

### General Drain Piping Information

All ceiling-cassette indoor units generate water during cooling operation, therefore, properly handling this condensation must be considered.

Ceiling-cassette indoor units include factory-installed drain pumps. Depending on the location of the indoor unit, condensation can be drained directly to the outside of the building, or a common indoor unit drainage piping system can be installed.

### Flexible Drain Hose

Ceiling-cassette indoor units include a factory-provided flexible drain hose (with two clamps) to connect the indoor unit to the drain piping / drain piping system.

If necessary, the drain hose can be extended. When the bottom surface of the indoor unit is at an elevation below the receiving building drain line connection, install an inverted trap at the top of the condensate pump discharge riser before connection to the building drain pipe.

Figure 91: Flexible Drain Hose Connection.



### ⚠ WARNING

The threaded rod hangers (bolts) and hardware must be securely tightened to prevent the unit from falling from its installation location. There is a risk of personal injury from falling equipment.

Figure 90: Ceiling-Cassette Indoor Unit Drain Pump to Drain Piping System.

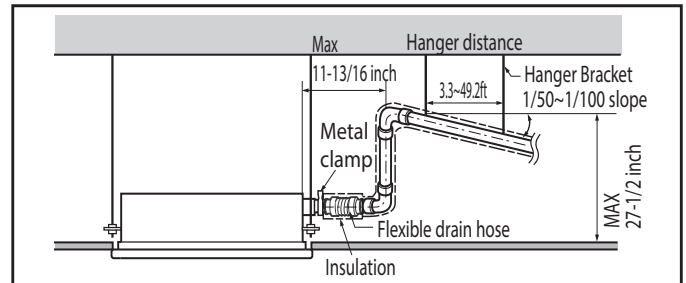

Table 58: Ceiling-Cassette Indoor Unit Drainage Specifications.

Indoor Unit	Drain Type	Drain Pipe Dia. (OD / ID, in.)
One-Way Ceiling Cassette	27-9/16 in.	Ø1-1/4 / Ø1
Two-Way Ceiling Cassette	(700 mm) Max. Lift	
Four-Way Ceiling Cassette	Drain Pump, Factory Installed	

## General Drain Piping Information

### Flexible Drain Hose, continued.

When the receiving drain line is mounted horizontal, connect the inverted trap to the top half of the pipe. The connection point of the inverted trap to the building drain pipe must always be to the top half of the pipe and must never be over 45° either side of the upper most point of the horizontal building drain line.

If connecting to a vertical drain line or plumbing system vent line, connect the IDU condensate pump discharge line using a Y-45 fitting with the double end of the Y-45 fitting facing up. When connecting to a vertical drain line include an inverted trap at the top of the IDU condensate pump discharge riser before connection to the Y-45 fitting.

### Drain Piping

- Drain piping must have down slope (1/50 to 1/100).
- Any holes through the ceilings, walls, etc., must be large enough to accommodate the drain piping and insulation.
- The outside diameter of the drain connection on the indoor unit is 1-1/4 inches.
- Drain piping material is polyvinyl chloride pipe (1 inch).

⊘ To prevent reversal flow, do not provide up and down slope.

### Drain Leak Test

A leak test must be performed 24 hours after the drainage system has been installed.

### Drain Pipe Insulation

Install field supplied polyethylene foam insulation 5/16 inch thick or greater on the flexible drain pipe and position snugly against indoor unit.

### Note:

Ensure the indoor unit, refrigerant piping, drain piping, and power wiring / communication cables are properly supported with anchor bolts and clamp hangers positioned at 3.3 to 4.9 foot intervals.

### Common Indoor Unit Drainage System

It is usual work practice to connect individual indoor unit drain pipes to one common indoor unit drainage system.

The diameter of the common vertical drain pipe must be as large as necessary. The diameter of the horizontal pipe must be the same or larger than the vertical drain pipe. To avoid property damage in the event of the primary drain becoming clogged, and to optimize drain system performance, it may be prudent to install a secondary drain line.

Design the drain system to plan for winter operation (condensate line may freeze up if condensate does not properly drain away). Drain all generated condensate from the external condensate pan to an appropriate area. Install a trap in the condensate lines as near to the indoor unit coil as possible. To prevent overflow, the outlet of each trap must be positioned below its connection to the condensate pan. All traps must be primed, insulated, and leak tested.

Figure 92: Drain Piping Slope.

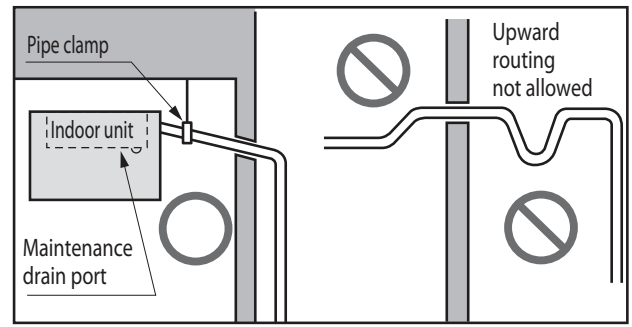
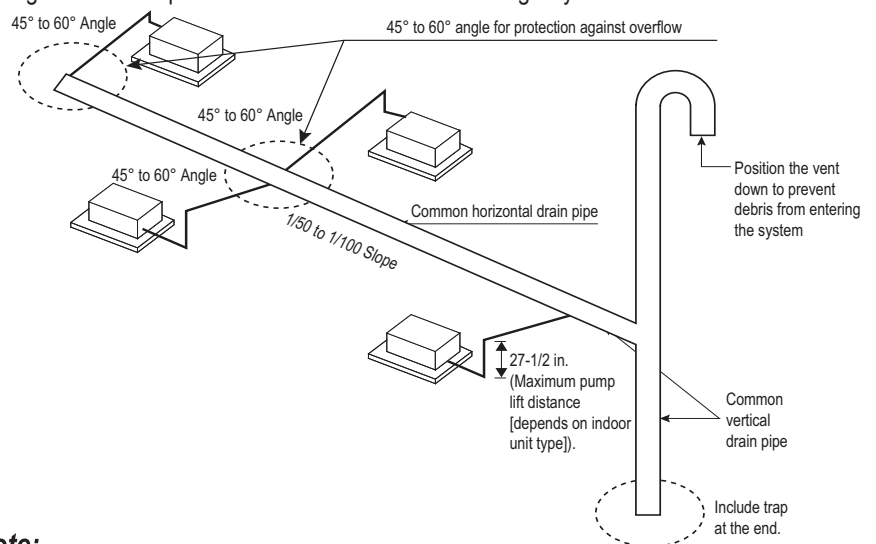

Figure 93: Example of a Common Indoor Unit Drainage System.



### Note:

- It is recommended that a dedicated drain pipe be installed for the air conditioning system. If the indoor unit drainage system is shared with a rainwater drain, waste water, or any other type of building drain system, back flow, leaks, ice may form, or noxious odors may infiltrate the air conditioning system.
- Install a trap if the drain access to the outside faces an undesirable location (i.e., sewer), otherwise, noxious odors may infiltrate the air conditioning system.

## Connecting the Power Wiring / Communication Cable

### **⚠ DANGER**

High voltage electricity is required to operate this system. Adhere to the National Electrical Codes and these instructions when wiring. Always ground the unit following local, state, and National Electrical Codes. Read the safety summary at the beginning of this manual.

- Secure all field wiring connections with appropriate wire strain relief. Improperly securing wires will create undue stress on equipment power lugs. Inadequate connections will generate heat, cause a fire and physical injury or death.
- Properly tighten all power connections. Loose wiring will overheat at connection points, causing a fire, physical injury or death.

### **Note:**

- Connect the indoor unit input power cable but  do not apply power to the indoor unit until authorized to do so by the system commissioning agent. Inappropriate power connection can result in equipment damage and will void the LG limited liability warranty.
- When connecting the communications bus between the outdoor unit, indoor unit(s), and heat recovery unit(s), it does not matter what physical path or route the wire takes. The installer can use discretion when choosing the order the components are connected to the communications bus, but must maintain the daisy chain and polarity configuration.
- Failure to follow any of these power and communications wiring guidelines or instructions will cause communications errors and unit malfunction.

### Do Not's

- Never use wire caps and never splice communications cables.
- Never connect zone controllers or other central controllers or LG building management system gateways to the indoor unit / outdoor unit communications cable.

### **Connection Procedure**

Indoor unit installation best practices are to connect control wiring (low voltage) and then connect power wiring (high voltage).  Do not apply power to the indoor unit or any Multi V system component until authorized to do so by the system commissioning agent.

1. Ensure the input power is disconnected and there is no power on the power input cable.
2. Remove the knock-out plugs from the control box. Remember the communications cable and the power cable must enter the control box through different knockouts.
3. Field-install a plastic or rubber grommet in the knockout holes to prevent wire chaffing.
4. If using conduit, connect the conduit to the control box using field-provided fittings and industry best-practice procedures.
5. Separately route the power wiring and communications cables to the unit's terminal block (see figures on the following pages).  Do not route the communications cable near the power cable. Two-way and four-way cassettes feature wiring and cable paths on opposite side of the indoor unit. Provide at least three (3) to four (4) inches of slack cable at each indoor unit.

### **Note:**

Power wiring is field supplied. Wire size is selected based on the larger MCA value, and must comply with the applicable local and national codes.

6. Connect the power wiring to the terminal block connections. Ensure the screws securely connect the wire to the terminals and are not loose.
  - For One-Way Cassettes: Terminal Block 1(L1) and 2(L2) connections.
  - For Two-Way and Four-Way Cassettes: Terminal Block L(L1) and N(L2) connections.

## Wiring Guidelines

---

---

7. Connect the field-provided communications cable to the 3(A) and 4(B) terminal block connections. Polarity matters on the outdoor unit to indoor unit / heat recovery unit communications bus, and must be maintained throughout the entire system. Be sure to connect 3(A) terminals to A terminals and 4(B) terminals to B terminals. Refer to the next pages for indoor unit wiring connections, the Outdoor Unit Installation Manual for information regarding the outdoor unit and heat recovery unit wiring connections, or review the wiring diagrams on the applicable units.

### Note:

- Cross connecting the 3(A) and 4(B) terminals will cause communications errors and system malfunction.
  - Field-provided communication cable between Master ODU to IDUs / HRUs to be 18 AWG, 2-conductor, twisted, stranded, shielded. Ensure the communication cable shield is properly grounded to the Master ODU chassis only.  Do not ground the ODU to IDUs / HRUs communication cable at any other point. Wiring must comply with all applicable local and national codes.
8. If a remote controller is to be installed, connect the remote controller's cable to the indoor unit's remote controller connection. Controller connections depend on type of indoor unit being installed. Some indoor units use terminal block connections; other indoor units use Molex connections. See the wiring diagram for each specific indoor unit.
  9. Connect any additional cables required for the installation such as those for the decoration panels.

**One-Way Cassette TT, TU Frames**

Figure 95: Typical TT, TU Frame Wiring / Cable Routing.

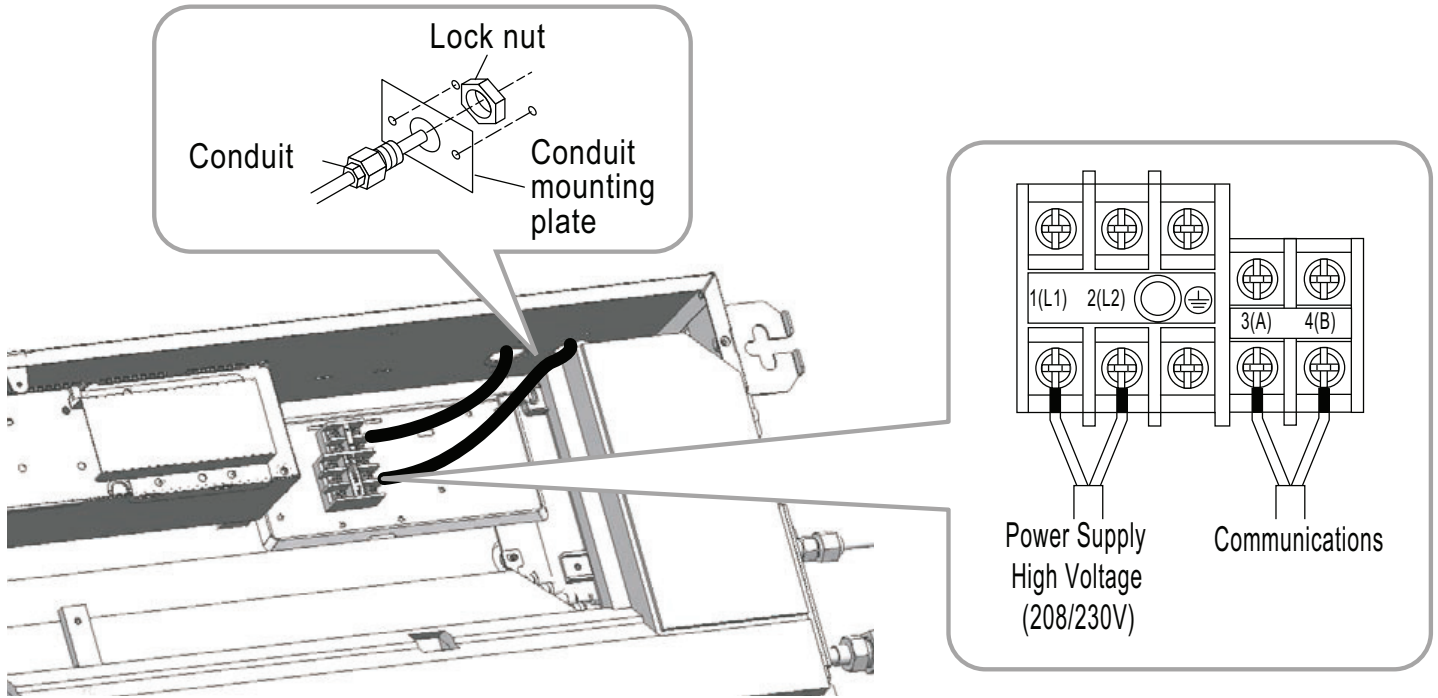
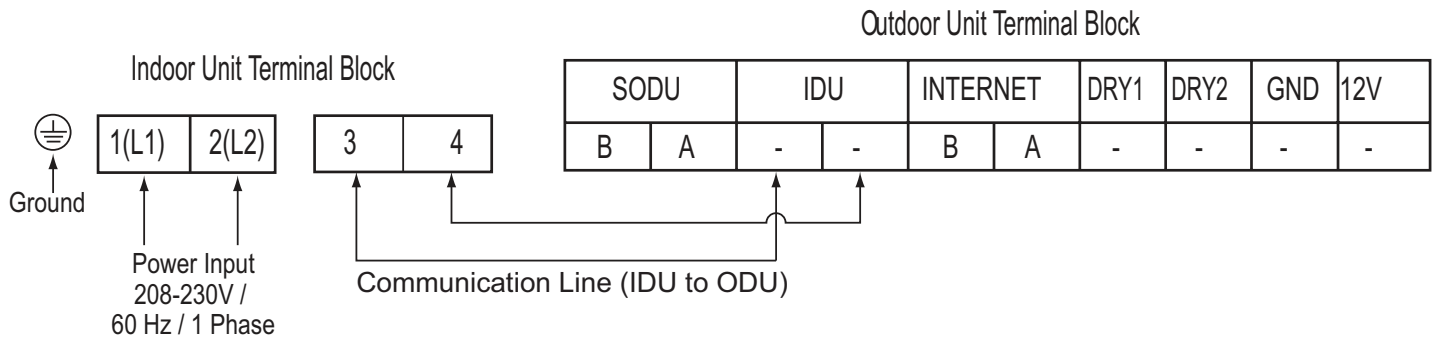

Figure 94: TT, TU Frame Wiring / Cable Connections.



### Two-Way Cassette TS Frame

Figure 96: Typical TS Frame Wiring / Cable Routing.

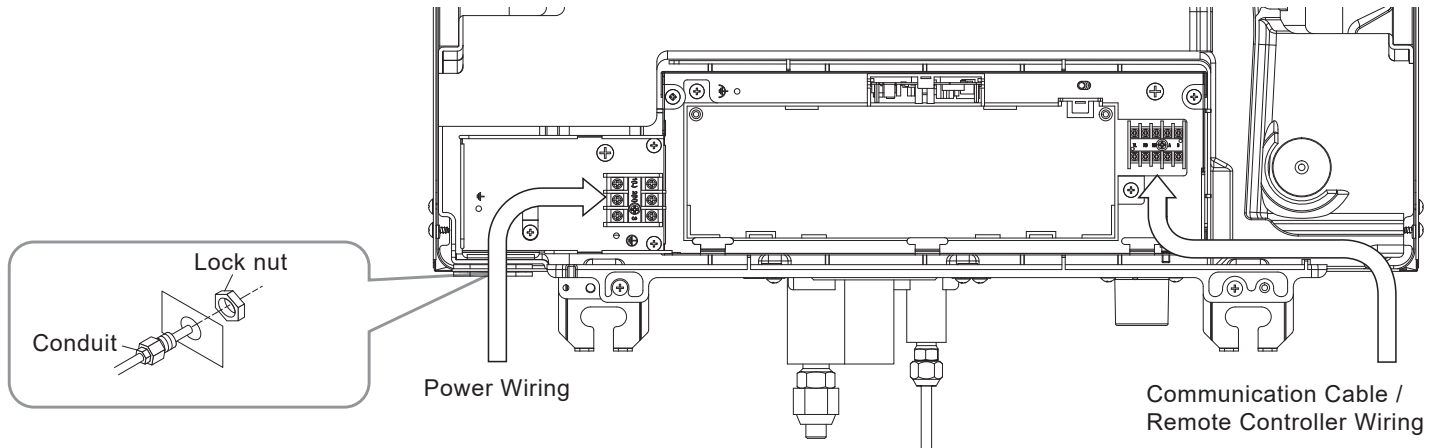
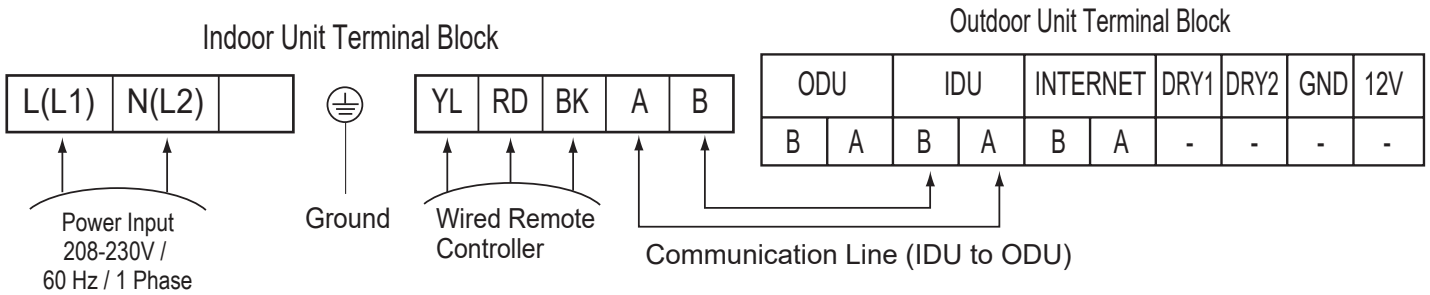

Figure 97: TS Frame Wiring / Cable Connections.



**Four-Way Cassette TR, TQ, TM, TN Frames**

Figure 98: Typical Four-Way Cassette Wiring / Cable Routing.

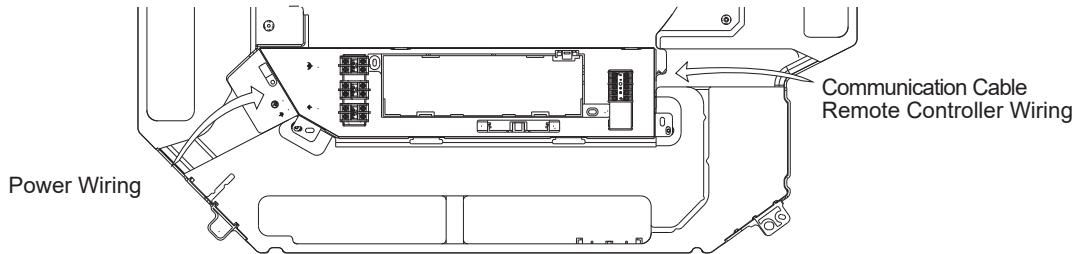

Figure 99: Typical Four-Way Cassette Wiring / Cable Routing, Side View.

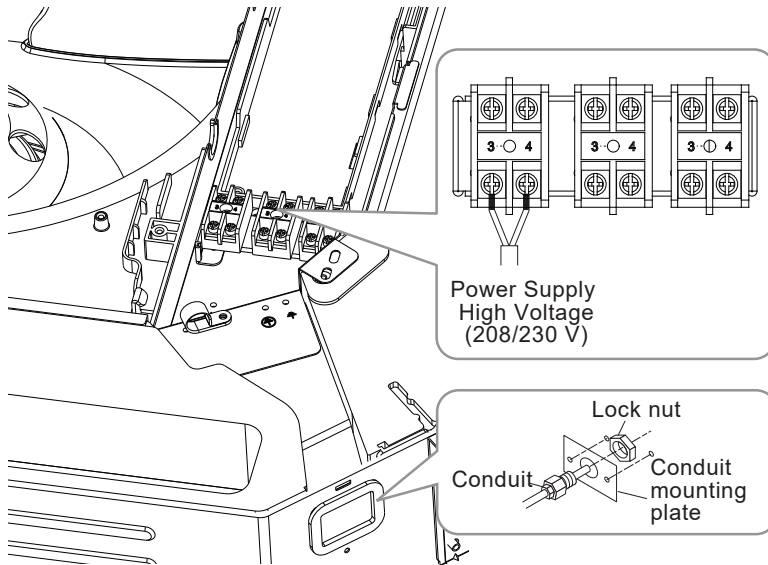
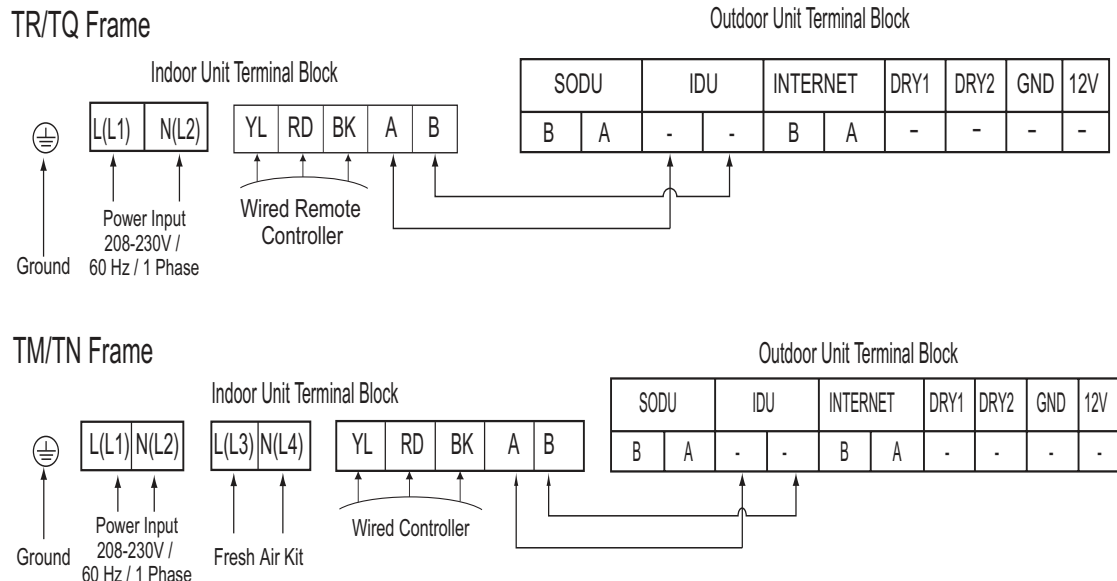

Figure 100: Four-Way Ceiling-Cassette Wiring / Cable Connections.



Due to our policy of continuous product innovation, some specifications may change without notification.  
 © LG Electronics U.S.A., Inc., Englewood Cliffs, NJ. All rights reserved. "LG" is a registered trademark of LG Corp.

## Wired Controller Placement

### Wired Controller Placement

Wired controllers include a sensor to detect room temperature. To maintain comfort levels in the conditioned space, the wired controller must be installed in a location away from direct sunlight, high humidity, and where it could be directly exposed to cold air. Controller must be installed four (4) to five (5) feet above the floor where its display can be read easily, in an area with good air circulation, and where it can detect an average room temperature.

- ⊘ Do not install the wired controller near or in:
- Drafts or dead spots behind doors and in corners
  - Hot or cold air from ducts
  - Radiant heat from the sun or appliances
  - Concealed pipes and chimneys
  - An area where temperatures are uncontrolled, such as an outside wall

Figure 101: Proper Location for the Wired Controller.

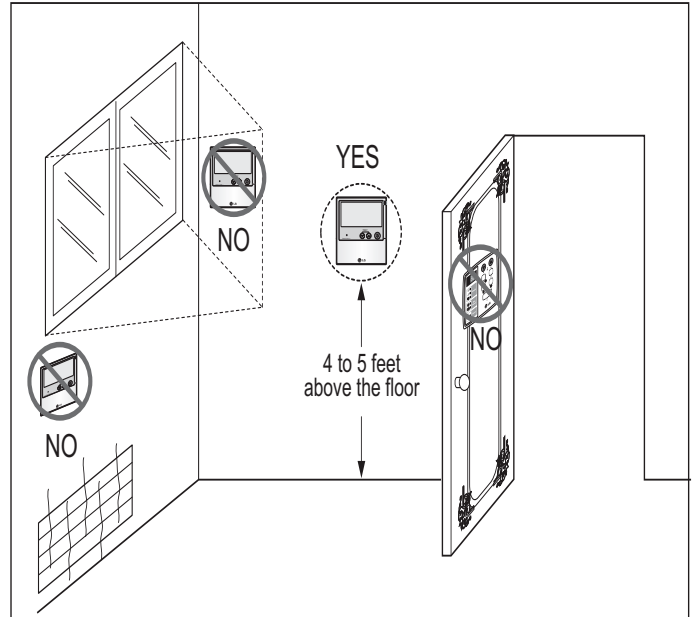

### Optional WiFi Control

Wifi control is an option for ceiling cassette IDUs. Wifi control requires the optional wifi module PWFMD200 and the Smart ThinQ app on a compatible device such as a smartphone. Install the wifi module by connecting it to the CN\_WF connector on the IDU motherboard. Refer to the Smart ThinQ manual for operation details.



Table 59: Acronym Table.

ABS	Acrylonitrile Butadiene Styrene	IDU	Indoor Unit
AC	Air Conditioner/Alternate Current	kW	Kilowatts
ACP	Advanced Control Platform	in Aq	inches water
AHU	Air Handling Unit	ISO	International Standards Organization
ASHRAE	American Society of Heating, Refrigeration, and Air Conditioning	LATS	LG Air Conditioning Technical Solution software
ASTM	American Society for Testing and Materials	LED	Light Emitting Diode
AWG	American Wire Gauge	LEED	Leadership in Energy and Environmental Design
AWHP	Air-to-Air Water Heat Pump	MBh	Thousands BTUs per hour
BLDC	Brushless Digitally-Controlled	MCA	Minimum Circuit Ampacity
BTL	BACnet® Testing Laboratories	mm	Millimeter
Btu/h	British Thermal Unit per Hour	MOP	Maximum Overcurrent Protection
CAA	Clean Air Act	OD	Outside Diameter
CFM	Cubic Feet per Minute	ODU	Outdoor Unit
CFR	Code of Federal Regulations	PI	Power Input
DB	Dry Bulb	PTAC	Packaged Terminal Air Conditioner
dB(A)	Decibels with "A" frequency weighting	SHC	Sensible Heat Capacity
DPST	Double-Pole Single Throw	SMACNA	Sheet Metal & Air Conditioning Contractors' National Association
DX	Direct expansion	RPM	Revolutions per Minute
EEV	Electric Expansion valve	TC	Total Capacity
EPDM	Ethylene Propylene Diene M-Class Rubber	USD	United States Dollar
EMF	Electromagnetic Field	UL	Underwriters Laboratories
ESP	External Static Pressure	V	Voltage
ETL	Electric Testing Laboratories	VAV	Variable Air Volume
GND	Ground	VRF	Variable Refrigerant Flow
H/M/L	High/Medium/Low	W	Watts
HVAC	Heating, Ventilating and Air Conditioning	WB	Wet Bulb
Hz	Hertz	wg	Water Gauge
ID	Inside Diameter		



LG Electronics, U.S.A., Inc.  
Air Conditioning Technologies  
4300 North Point Parkway  
Alpharetta, Georgia 30022  
[www.lghvac.com](http://www.lghvac.com)

EM\_MultiV\_CeilingCassette\_IndoorUnits\_6\_20  
Supersedes: EM\_MultiV\_CeilingCassette\_IndoorUnits\_12\_19  
EM\_MultiV\_CeilingCassette\_IndoorUnits\_6\_18  
EM\_MultiV\_CeilingCassette\_IndoorUnits\_8\_17  
EM\_MultiV\_CeilingCassette\_IndoorUnits\_8\_16  
EM\_MultiV\_CeilingCassette\_IndoorUnits\_4\_16